

INDUSTRIAL TOOLS AND SOLUTIONS

2016

Atlas Copco

ATLAS COPCO TOOLS NORTH AMERICAN OFFICES

USA

The Auburn Hills facility is the new home of Atlas Copco Tools and Assembly Systems, USA. Opened in the fall of 2014, this site is frequently used to host training courses and seminars. Customers are encouraged to visit and test run our products in our state-of-the-art demonstration areas.

3301 Cross Creek Parkway Phone: 800-859-ERGO
Auburn Hills, MI 48326 Service Technical Support:
866-TOOLFIX
Fax: 248-373-3001

















CANADA

The Canadian office was opened in 1984 and is a sales and service facility. This office has had ISO 9002 approval since 1997, a quality system that is applied to sales, service, and distribution of air powered and electric hand held power tools.

403 Mattheson Blvd East Phone: 901-501-9968
Mississauga, Ontario L4Z2H2 Fax: 901-501-9790



CONTENTS

| | | | |
|---|------------|--|------------|
|  PNEUMATIC ASSEMBLY TOOLS | 9 |  GRINDERS | 222 |
| Pneumatic screwdrivers | 12 | Turbine grinders and sanders | 226 |
| Impact wrenches | 23 | Die grinders | 229 |
| Hydraulic impulse nutrunners – ErgoPulse | 28 | Straight grinders | 231 |
| Controlled impulse nutrunners – Pulsor C | 37 | Angle grinders | 233 |
| Pneumatic nutrunners | 40 | Angle sanders | 235 |
|  HYDRAULIC TOOLS | 71 | Orbital and random orbital sanders | 237 |
| RT wrenches, square drive | 73 | Dust extraction | 239 |
| RTX wrenches, low torque | 76 | Router | 242 |
|  BATTERY ASSEMBLY TOOLS | 83 | Circular cutters | 243 |
| BCP screwdriver, clutch type | 86 |  PERCUSSIVE TOOLS | 244 |
| BCV nutrunner, clutch type | 86 | Chipping hammers | 247 |
| Tensor STB nutrunners transducerized type | 88 | Scalers | 249 |
| Tensor SB nutrunners transducerized type | 95 | Chisels | 251 |
|  ELECTRIC ASSEMBLY TOOLS AND SYSTEMS | 96 | Riveting systems | 254 |
| Electric screwdrivers | 99 | Riveting hammers | 255 |
| EBL | 100 | Bucking bars | 257 |
| MicroTorque | 102 |  DRILLS | 258 |
| Tensor ES | 108 | Pistol grip drills | 261 |
| Tensor DL | 109 | Straight drills | 265 |
| Tensor SL | 110 | Angle drills | 267 |
| Tensor SR | 111 | Modular drills | 271 |
| Electric nutrunners | 115 | Micro stop drills | 274 |
| Tensor ES | 117 | Tappers | 276 |
| Tensor DS | 118 | Screw-feed drills | 278 |
| Tensor ST | 121 | Positive feed drills | 279 |
| Tensor STR | 128 |  AUTOMATIC DRILLING AND TAPPING UNITS | 282 |
| Tensor SR | 130 | Automatic drilling and tapping units | 284 |
| Controller and software | 139 | Dimension sketches | 287 |
| Power Focus 600 | 140 |  AIR LINE ACCESSORIES | 290 |
| Power Focus 6000 | 141 | Air preparation units | 293 |
| DS/DL Drive | 143 | Optimizer air tool oil | 297 |
| Power Focus 4000 | 144 | Quick couplings | 298 |
| Software ToolsTalk | 146 | Claw couplings | 306 |
| Quality Integrated Fastening | 147 | Ball valves | 307 |
| Station hardware | 149 | Swivel connectors | 308 |
| Station software | 151 | Fittings | 309 |
|  TOOL ACCESSORIES | 153 | Hoses | 310 |
| TPS Controller | 156 | Spiral hoses | 315 |
| Torque arms | 157 | Productivity kits | 316 |
| Bits and power sockets | 167 | Pre-mounted hose kits | 317 |
|  FIXTURED APPLICATIONS | 174 | Hose reels | 318 |
| Fixture nutrunners QST | 177 | Balancers | 322 |
| Fixture nutrunners ETX | 181 | Blow guns | 325 |
| Controllers and software | 183 | Test equipment | 325 |
| PowerMACS | 184 |  AIR MOTORS | 326 |
| MSB, DB, GB | 185 | Vane air motors | 327 |
| Power Focus | 188 | LZB vane air motors | 328 |
| Software ToolsTalk | 189 | LZL vane air motors | 328 |
|  QUALITY ASSURANCE AND MANUAL FASTENING | 190 | Air motor support | 329 |
| STa 6000 analyser | 192 |  HOIST AND TROLLEYS | 330 |
| SRTT-L Transducers | 195 | Air hoists | 332 |
| QRTT Transducers | 196 | Trolleys | 333 |
| IRTT-B Transducers | 196 |  SERVICE | 335 |
| SRTT-B Transducers | 197 | Service packages | 337 |
| MRTT-B Transducers | 198 | Service packages for new equipment | 339 |
| MRTT-C Transducers | 199 | DECLARATION OF NOISE AND VIBRATION EMISSION | 341 |
| ACTA MT Transducer | 200 | TOOL KEY | 347 |
| Mechanical wrenches | 202 | TOOL DESIGNATIONS | 353 |
| STwrench | 212 | | |
| Test Benches | 218 | | |
| BLM Torque Supervisor | 221 | | |



Whatever your **business** we can add **value**

From big bolts to tiny fasteners, from offroad vehicles to the electronics industry – whatever your business, Atlas Copco has the technology you need to stay ahead of the game. With advanced system, quality assurance and process software, and high-tech tools and assembly systems, our range offers solutions for durability, high quality and sustainable productivity.



You talk, we listen

For us, listening is crucial. Whether you build vehicles, aircraft, appliances or electronics, your ongoing feedback gives us valuable insights into your business and the challenges you face to remain competitive. Our response? A continuous stream of innovative software solutions supporting tooling hardware that raises the productivity and sustainability of your operation.

We lead, others follow

We lead the world for advanced process control and quality assurance software supporting the operation of high tech operator-friendly tools. We currently have more than 4 000 tools in our range and our dynamic product development program generates a large number of new solutions every year.

Lean production

In the automotive and other industries our high-performance, hand-operated and fixtured assembly tools, advanced system, quality assurance and process software and extensive know-how make a major contribution to lean production. Every third car in the Western world

was built using our cutting-edge assembly solutions. We are also implementing lean concepts throughout our own operations worldwide.

Safety critical applications

On assembly lines in the manufacturing industries many joints are safety critical. Atlas Copco's market-leading assembly process software, controlled fastening tools, and fixtured solutions enable you to meet today's demands for joint validation, documentation and traceability. Also, with advanced operator guidance solutions built into many of our systems and products, the risk of reworking is drastically reduced.

Productivity starts with people

We continue to lead the field for ergonomically designed tools that help minimize operator fatigue and increase individual productivity. Outstanding examples are our vibration-damped riveting systems, chosen by major aircraft manufacturers, and our turbo-powered grinders that have made heavy tasks lighter for tool operators in heavy metal fabrication operations.

Committed to sustainable productivity

Our brand promise embraces virtually all aspects of our operations. It means that at Atlas Copco we all do everything we can to ensure reliable, sustainable results with responsible use of resources – human, natural and capital.

In our own operations worldwide we focus on maintaining a high competence level, and health and safety in the workplace. We constantly strive to reduce the impact of production on the environment.

Our focus on sustainability is driven by our core values, in which we all take pride, and this is clearly reflected in our innovative portfolio. We continuously develop new system and process software solutions that assure quality and raise productivity, along with energy efficient tooling offering lowest cost of ownership. Safeguarding health and boosting productivity in your operation through better ergonomics have long been part of our business philosophy.

All-in-all, we are working for a better society around us.



Close to your
operation
in touch with your **needs**

Keeping your production on-line around the clock is our priority. And with resources in more than 90 countries, we are never far away. Teaming up with Atlas Copco specialists, distributors and service engineers means having a global partner with a local responsibility.

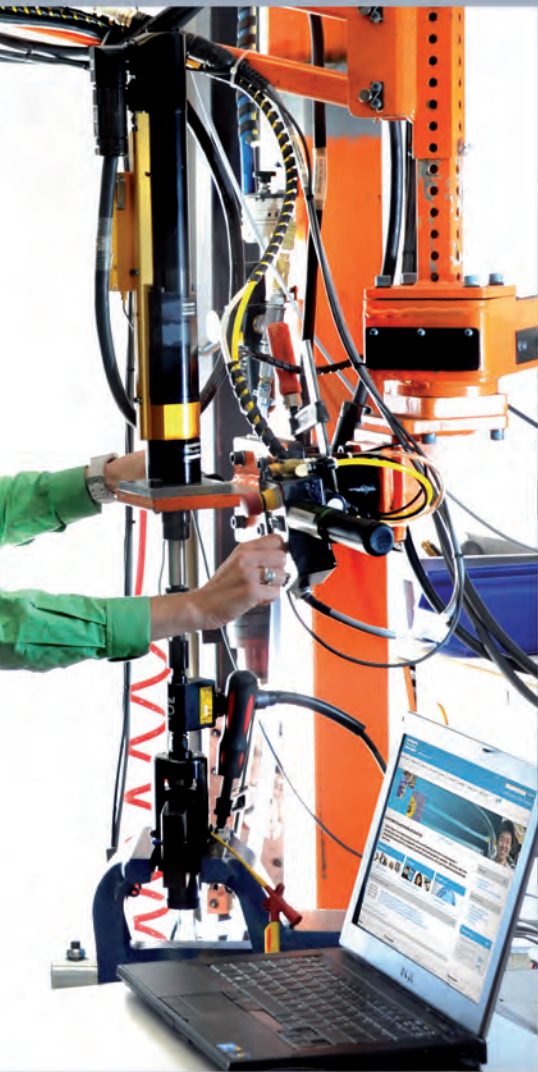

Customer Centers

Unique among competitors, Atlas Copco has Customer Centers throughout the world. Their common goal is to give you the best return on your investment. Once the tools are installed, our entire organization is dedicated to keeping your operation on-line.

Application centers

Our strategically located Application Centers configure complete assembly stations with process monitoring and control for the automotive, aerospace and other industries where joint quality is crucial. Using standard components we can deliver a complete tightening station for quality integrated fastening in just three weeks.

Worldwide service

Our global service organization, with more than 1 000 certified technicians, offers an unmatched level of customer support. The Atlas Copco certification program ensures that wher-

ever you are in the world you receive the same high quality service. Take advantage of our unique Industrial Service offering, including: Calibration, Production Optimization, Production Transformation, and Customer Training. Let us show you what we can do for your bottom line.

On-site Tool Management Centers

Perhaps your operation is large enough to justify an on-site Atlas Copco Tool Management Center. Let us take care of all your day-to-day tool service and maintenance needs and free you to focus on your core business.

Whatever your language

We offer customer training and a wide range of training materials, including e-learning, interactive presentations and pocket guides in several languages. Operator and service instructions, supplied with all products, are available in many languages. Installation, operation, main-

tenance and service instructions are available on our website.

Order-driven production

At our tool plant, production is order driven and lead times are extremely short. Before leaving our factory every tool and system is rigorously tested. Quality control and test data are stored for each product.

Fast delivery

Place orders by phone or on-line. Orders received before 16:00 are packed and shipped the same day. European customers receive deliveries from our standard range within 24 to 48 hours from our worldwide distribution warehouse in Belgium. Deliveries to other continents take up to 72 hours.



A truly **innovative** company striving for **excellence**

Maximum quality at all stages, from initial development to spare part delivery, is our target. With more than 4 000 tools and 400 patents – a steadily growing number – we can proudly call ourselves innovators. Ensuring that you'll always find a solution for your specific need.



Proof of company excellence

The ISO 9001 Certificate confirms that Atlas Copco Tools product company conforms to the Quality Standard ISO 9001.

Our quality policy is:

- To fulfill customers' expectations.
- To deliver problem-free products at the right time.
- To continuously improve our products, services and processes.
- To have motivated personnel with clearly defined goals.

In effect it means you know what you are getting. Carefully specified manufacturing processes ensure that every product leaving our factory meets exactly the same standards of quality and performance.

EC declaration of conformity

From January 1, 1995, all machines produced by Atlas Copco conform with the EC Machine Directive which focuses on safety. From December 29, 2009 the directive is 2006/42/EC.

Each Atlas Copco tool bears the CE marking and is accompanied by detailed safety and operating instructions and a declaration of conformity.

Our obligations

- The manufacturer must ensure that the machine is designed in conformance with the standards laid down for the machine type in question.
- The machine must be accompanied by a declaration of conformity.
- The design project must be thoroughly documented.
- The sign affixed to the machine must carry:
 - Name and address of manufacturer.
 - Product designation and technical data, defined in the relevant standard.
 - The CE marking.
 - Country and year of manufacturer.

The machine must be accompanied by safety and operating instructions warning of possible hazards when the machine is in use. The instructions must also include a declaration of noise and vibration based on tests performed according to test codes such as EN standards or other recognized standards. The instructions must be written in all EC languages.

Ergonomics

Our goal is to supply the market with the most ergonomic and operator friendly tools available. For us ergonomics embraces all the factors involved in the interaction between the equip-

ment and the operator. Important parameters are handle design, load on the operator, torque reaction from tightening tools, temperature, vibration emission, noise emission, dust and oil. The vibration and noise values included in the instructions and in this catalogue are measured according to internationally accepted standards. For vibration we use the ISO 28927 series and for noise ISO 15744. The values are emission values primarily intended to compare tools.

Environment

We continuously strive to reduce our environmental impact. To achieve this we require all our major entities to be certified according to ISO 14001. The Environmental Management System focus areas include:

- Design for Environment – including environmental criteria in our design process.
- Improving energy efficiency in our production and product performance.
- Reducing hazardous substances in our production and products.
- Promoting sustainability “best practice” in our supply chain.
- Supplying environmental information to our customers.
- Providing environmental awareness training for our employees.

Your guide to the catalog



Accessories included

Under this heading a specification is given for each type of tool and of the parts (nipples, keys, guards, etc.) supplied with the tool. Instructions and a list of spare parts are always included in the package.

Optional accessories

Here you will find the specifications for most of the accessories. They are dependent on the job the tool is to be used for and have to be ordered separately.

Air consumption

The air consumption of the tools is stated in liters per second, l/s, and relates to free air, i.e., the compressed air expanded to atmospheric pressure. Unless otherwise stated, the figures are valid at a working pressure of 6.3 bar and indicate the maximum air consumption.

Maximum air consumption is valid for the tool without a speed governor when idling, i.e., when the tool is running at no load. A tool with a speed governor, has the maximum air consumption at the maximum power output.

Speed

The tool speeds are indicated in revolutions per minute, r/min, and indicate the idling speed, i.e., the speed at which the tool runs at no load and at a working pressure of 6.3 bar, if not otherwise specified. The speed at max. output is 50% of the idling speed for tools without a speed governor and 80 – 90% of the idling speed for tools with a speed governor.

Selected service kits to order

Under this heading, service kits for the most frequent service jobs done on the tool in question are listed.

Vibration and noise emission

Vibration and noise emission values are presented in a separate section at the end of the catalogue. From December 29, 2009 vibration emission shall be given as vibration total values (3-axes values).

Vibration values referring to the ISO 28927 are always given as a measured vibration value and an uncertainty. The uncertainty is an indication of the spread in the vibration when measured. The spread in the in-use vibration emitted in a real work situation is at least of the same magnitude, often considerably bigger.

Vibration values referring to ISO 28927 can in many cases also be used as rough estimates of the in-use vibration values when tools are used in typical applications.

In-use vibration is influenced by factors beyond our control such as poor maintenance,

pirate parts, unbalanced grinding wheels, etc.

When measuring noise, Atlas Copco uses the standard ISO 15744. The figure given in this catalogue is the measured sound pressure level. If the measured value exceeds 80 dB(A), the sound power level is also given. The standards describe how to calculate this figure. The uncertainty in the figures from variations in the test method and production is 3 dB(A). In-use noise values close to the operator's ear may differ considerably from the given values particularly since in many applications the sound from the process is higher than the unloaded tool noise.

We, Atlas Copco Tools, cannot be held liable for the consequences of using the declared values, instead of values reflecting the actual exposure, in an individual risk assessment in a workplace situation over which we have no control. We recommend a program of health surveillance to detect early symptoms which may relate to noise or vibration exposure, so that management procedures can be modified to help prevent future impairment.

| | | |
|---------------|---|------------------------|
| Length | | |
| 1 in | = | 0.0254 m |
| 1 m | = | 39.3701 in / 3.2808 ft |
| 1 mm | = | 0.0393701 in |

| | | |
|---------------|---|-----------|
| Weight | | |
| 1 lb | = | 0.4536 kg |
| 1 kg | = | 2.2046 lb |

| | | |
|---------------|---|-----------|
| Torque | | |
| 1 kpm | = | 9.8067 Nm |
| 1 Ft lb | = | 1.3558 Nm |

| | | |
|---------------|---|----------------------------|
| Torque | | |
| 1 In lb | = | 0.1130 Nm |
| 1 Nm | = | 0.1020 kpm 0.7376 ft lb |

| | | |
|---------------------------|---|-----------------------------------|
| Pressure | | |
| 1 bar | = | 100 kPa |
| 1 kp/cm ² (at) | = | 98.0665 kPa |
| 1 psi | = | 6.8948 kPa |
| 1 kPa | = | 0.0101972 kp/cm ² (at) |

| | | |
|--------------|---|--------------------------|
| Power | | |
| 1 kpm/s | = | 9.8067 W |
| 1 hp | = | 745.7 W 101.972 kpm/s |
| 1 kW | = | 1.3410 hp |

| | | |
|-----------------------|---|-------------|
| Flow | | |
| 1 m ³ /min | = | 16.6667 l/s |
| 1 cfm | = | 0.4720 l/s |
| 1 m ³ /h | = | 0.2778 l/s |
| 1 l/s | = | 2.1189 cfm |

PNEUMATIC ASSEMBLY TOOLS

Contents

| | |
|-------------------------------|----|
| Introduction | 10 |
| Screwdrivers | 12 |
| Pistol grip models | 14 |
| Straight models..... | 18 |
| Angle models..... | 20 |
| Impact wrenches | 23 |
| Pistol grip models | 25 |
| Straight models..... | 26 |
| Hydraulic impulse nutrunners | 28 |
| ErgoPulse | |
| Pistol grip models | 30 |
| Straight models..... | 33 |
| Controlled impulse nutrunners | 37 |
| Pulsor C..... | 38 |
| Nutrunners | 40 |
| Angle models..... | 41 |
| Straight models..... | 57 |
| Pistol grip models | 62 |

Fast, accurate and operator friendly

Atlas Copco supplies a broad range of pneumatic assembly tools designed to give you highest possible productivity on your assembly line. The result of decades of development, the tools include ergonomically designed screwdrivers, pulse tools, nutrunners and impact wrenches, that offer superior productivity. High productive tools means less air consumption that translates into big energy savings since energy consumption and CO₂ emissions are reduced. Vibration and noise levels are minimized, power-to-weight ratios are high. It all adds up to maximum operator comfort and highest individual productivity.

IMPACT WRENCHES (LMS)

Impact wrenches have unmatched speed and power-to-weight characteristics, which makes them ideal e.g. for loosening applications. They productify raw power and cover a wide torque range including both non shut-off and shut-off models. They are also reaction free.

IMPULSE TOOLS (ERGOPULSE XS, PTS, PTX)

Impulse tools are the ideal choice for fast and reaction-free one-hand tightenings. They have the same advantages as impact wrenches but with higher accuracy. In addition you will get a tool with good ergonomics, which means lower sound levels and less vibrations. Pulse tools also have a longer service life. They come in non shut-off and shut-off version.

CONTROLLED IMPULSE TOOLS (PULSOR C)

The Pulsor C is a further developed pulse tool with advanced error-proofing functionality. It is a multi torque pulse tool for quality critical tightenings offering complete control of the tightening process with result reporting.

SCREWDRIVERS

We offer a wide range of extremely accurate, ergonomically designed screwdrivers for all kinds of jobs involving smaller screw sizes, up to M6. All models are lubrication-free.

- **Direct drive (LUD, LUF, HRD)**

The low cost alternative for wood and self-drilling screws.

- **Slip clutch (TWIST, LUF)**

Best for sheet metal screws, wood screws or self-tapping screws.

- **Shut-off control (LUM)**

Best practice in most cases, especially for machine screws and screws in plastic. Very good accuracy and lowest bit consumption.

NUTRUNNERS

Suitable for all kinds of tightening tasks from 0.5 Nm, nutrunners in Atlas Copco's extensive range are extremely accurate. Due to their ergonomic designs they are also very comfortable to operate. All models are lubrication-free.

- **Angle and straight type (LTV, LTD)**

Accurate workhorses for limited spaces suitable for high volume serial production. Very good accuracy, small angle head and possible to attach special heads. Low noise and vibration levels.

- **Pistol grip type (LMP, LTP)**

High torque tools for super fast, accurate tightenings. Low noise, and low vibration tools for operator comfort.

RTP NUTRUNNERS

Whatever your industry, if your operations include loosening or tightening heavy duty bolts, Atlas Copco's slim, lightweight RTP pneumatic nutrunner can help increase your productivity.

Among the smallest on the market, the RTP's slim gearpack gives you effortless access to bolts in cramped spaces. Tightening accuracy and repeatability are high. Noise and vibration levels are lower than in traditional impact wrenches.



Selection Guide

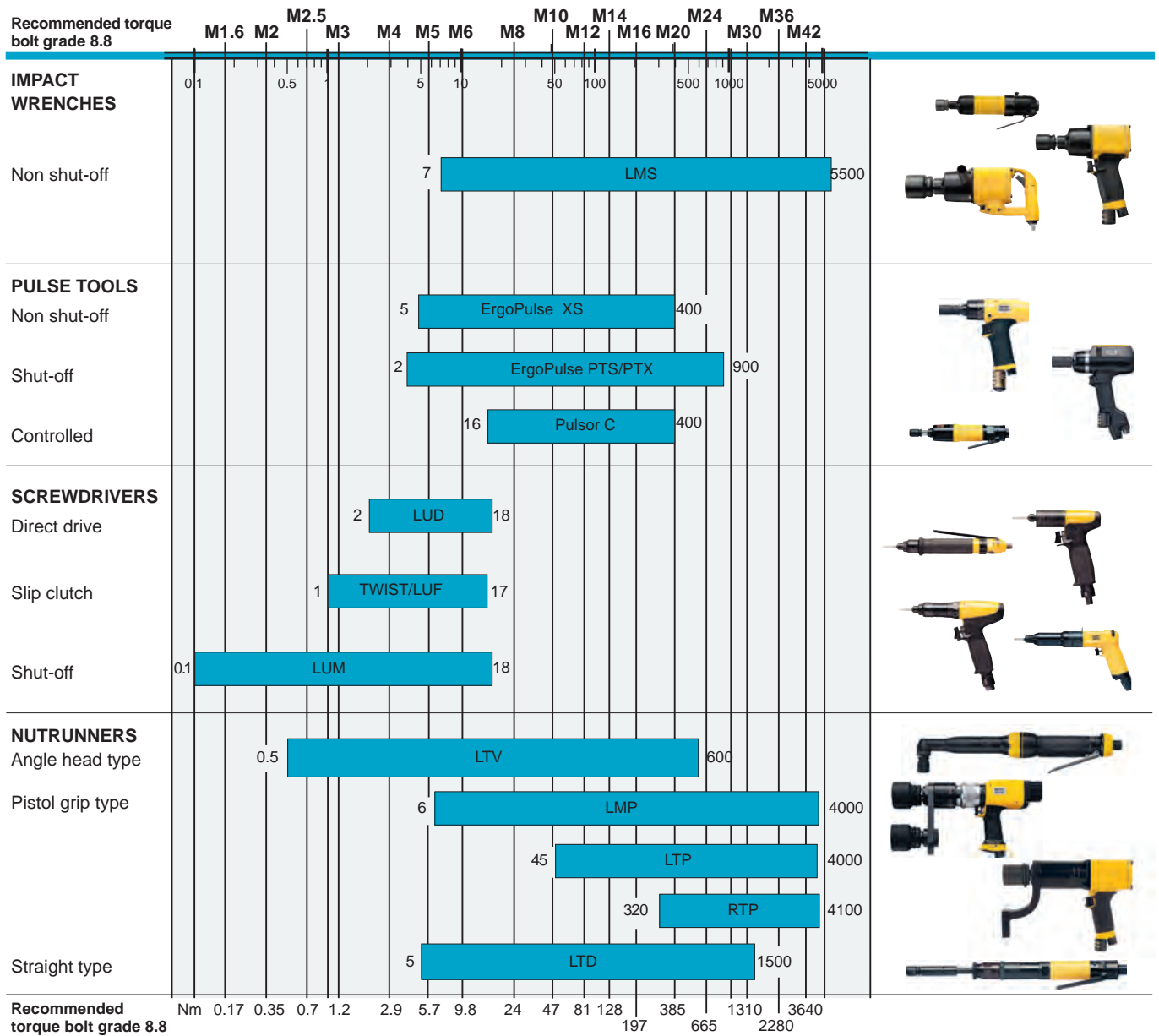

TORQUE RECOMMENDATIONS

The torque is important to ensure the required clamping force. The table shows the recommended max tightening torque for the most common types of screws and bolts: untreated, oil-smearred screws (friction coefficient = 0.125) with metric coarse thread. The torque corresponds to approximately 62% of tensile stress.

M-threaded screws/bolts Tightening torque Nm, according to ISO 898/1

| Thread | Bolt grade | | | | | | | Thread | Bolt grade | | | | | |
|--------|------------|-------|-------|------|------|-------|-------|--------|------------|------|------|------|------|------|
| | 3.6 | 4.6 | 4.8 | 5.8 | 8.8 | 10.9 | 12.9 | | 4.6 | 4.8 | 5.8 | 8.8 | 10.9 | 12.9 |
| M1.6 | 0.05 | 0.065 | 0.086 | 0.11 | 0.17 | 0.24 | 0.29 | M14 | 48 | 58 | 80 | 128 | 181 | 217 |
| M2 | 0.10 | 0.13 | 0.17 | 0.22 | 0.35 | 0.49 | 0.58 | M16 | 74 | 88 | 123 | 197 | 277 | 333 |
| M2.2 | 0.13 | 0.17 | 0.23 | 0.29 | 0.46 | 0.64 | 0.77 | M18 | 103 | 121 | 172 | 275 | 386 | 463 |
| M2.5 | 0.20 | 0.26 | 0.35 | 0.44 | 0.70 | 0.98 | 1.20 | M20 | 144 | 170 | 240 | 385 | 541 | 649 |
| M3 | 0.35 | 0.46 | 0.61 | 0.77 | 1.20 | 1.70 | 2.10 | M22 | 194 | 230 | 324 | 518 | 728 | 874 |
| M3.5 | 0.55 | 0.73 | 0.97 | 1.20 | 1.90 | 2.70 | 3.30 | M24 | 249 | 295 | 416 | 665 | 935 | 1120 |
| M4 | 0.81 | 1.10 | 1.40 | 1.80 | 2.90 | 4.00 | 4.90 | M27 | 360 | 435 | 600 | 961 | 1350 | 1620 |
| M5 | 0.60 | 2.20 | 2.95 | 3.60 | 5.70 | 8.10 | 9.70 | M30 | 492 | 590 | 819 | 1310 | 1840 | 2210 |
| M6 | 2.80 | 3.70 | 4.90 | 6.10 | 9.80 | 14.0 | 17.0 | M36 | 855 | 1030 | 1420 | 2280 | 3210 | 3850 |
| M8 | | 8.90 | 10.50 | 15.0 | 24.0 | 33.0 | 40.0 | M42 | 1360 | | 2270 | 3640 | 5110 | 6140 |
| M10 | | 17.0 | 21.0 | 29.0 | 47.0 | 65.0 | 79.0 | M45 | 1690 | | 2820 | 4510 | 6340 | 7610 |
| M12 | | 30.0 | 36.0 | 51.0 | 81.0 | 114.0 | 136.0 | M48 | 2040 | | 3400 | 5450 | 7660 | 9190 |

High accuracy, good ergonomics

Atlas Copco pneumatic screwdrivers bring accuracy and good ergonomics into the production process, while offering robust, reliable designs. The range includes models to fit any low torque application. The tools are available in pistol grip, angle and straight configurations with drive types spanning a wide range of speeds and torques.

In this range of pneumatic screwdrivers, the proven and patented Atlas Copco clutch design gives high torque accuracy and repeatable results over time. All screwdrivers are lightweight, with optimum non-slip grip and handle design for operator comfort. A fast shut-off clutch give minimum reaction impulse, thus reducing operator strain. All Atlas Copco screwdrivers can be used as lubrication-free.

A COMPLETE RANGE

Our pneumatic screwdrivers are available in pistol grip, angle and straight configurations. The LUM, TWIST, LUF and LUD models are pistol grip and straight tools, and the LTV is an angle tool.

SHUT-OFF TYPE SCREWDRIVERS

LUM and LTV models have a fast and accurate shut-off clutch for smooth performance and high quality tightening. They are suitable for joints with demands on torque accuracy, providing accurate tightening time-after-time, independent of variations in joint stiffness. Electro Static Discharge (ESD) approved models and RE models are available in this range. RE models enable a signal to be received from the tool, in order to control batch count. All RE models need to be combined with an external RE control system. Shut-off tools are the best choice for machine screws, thread-rolling screws and thread-forming screws for plastic.



SLIP CLUTCH TYPE SCREWDRIVERS

TWIST and LUF HR screwdrivers have a slip clutch that applies a pulsating force when the torque level is reached. These tools are suitable where the torque level may temporarily rise during the rundown phase, for instance when using sheet metal screws, wood screws or self-tapping screws.

DIRECT DRIVE TYPE SCREWDRIVERS

LUD and LUF HRD are direct drive screwdrivers that stall when final torque is reached. The torque level is adjusted by regulating the air pressure. LUD and LUF HRD are mainly used for self-drilling and wood screws.

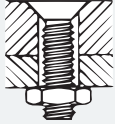
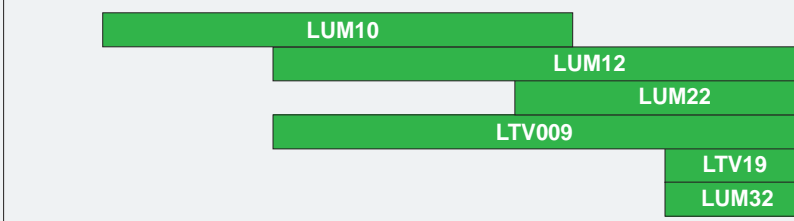
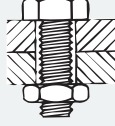
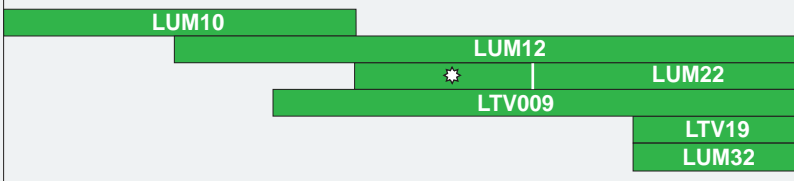
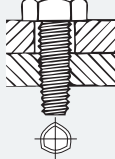
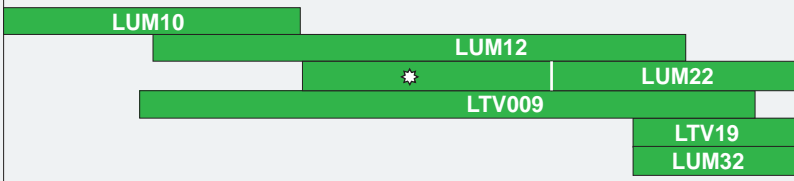
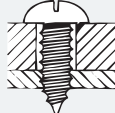
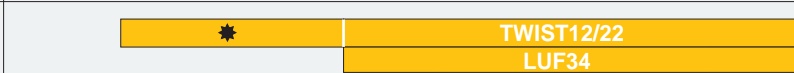
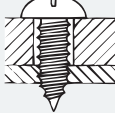
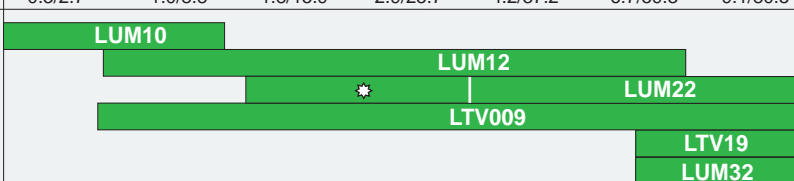
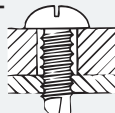
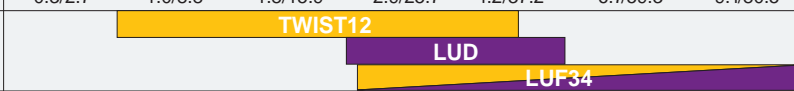

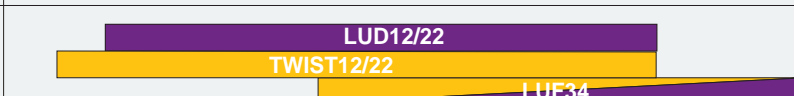
| SCREW TYPE | SCREWDRIVER | | | | | | | | | | |
|---|--|--|---------|----------|----------|----------|----------|----------|----------|----------|----------|
| | Ø Screw size | M1.6 | M2 | M2.5 | M3 | M3.5 | M4 | M5 | M6 | | |
| Machine screw 4.8 Property class 4.8 normal for cross recessed and slotted screws  | Torque Nm/in lb | 0.09/0.8 | 0.2/1.8 | 0.4/3.5 | 0.6/5.3 | 1.0/8.8 | 1.4/12.4 | 2.9/25.7 | 4.9/43.4 | | |
| | Recommended tool |  | | | | | | | | | |
| | Machine screw 8.8 Property class 8.8 normal for hexagon, Allen head and Torx®. Locking nut with plastic insert, increase torque 10%, mechanical-lock nut, increase torque 20%  | Torque Nm/in lb | 0.2/1.8 | 0.4/3.5 | 0.7/6.2 | 1.2/10.6 | 1.9/16.8 | 2.9/25.7 | 4.3/38.1 | 5.7/50.4 | 9.8/86.7 |
| Recommended tool | |  | | | | | | | | | |
| Thread rolling screw-M Property class between 8.8 and 10.9 due to case hardening. Taptite® and Swageform are examples  | | Torque Nm/in lb | | M2 | M3 | M4 | M5 | M6 | | | |
| | Recommended tool |  | | | | | | | | | |
| | Thread forming screw-ST  | Torque Nm/in lb | 0.3/2.7 | 1.0/8.8 | 1.8/15.9 | 2.9/25.7 | 4.2/37.2 | 6.7/59.3 | 9.1/80.5 | | |
| Recommended tool | |  | | | | | | | | | |
| Thread forming screw-ST for plastic  | | Torque Nm/in lb | 0.3/2.7 | 1.0/8.8 | 1.8/15.9 | 2.9/25.7 | 4.2/37.2 | 6.7/59.3 | 9.1/80.5 | | |
| | Recommended tool |  | | | | | | | | | |
| | Self drilling screw-ST  | Torque Nm/in lb | 0.3/2.7 | 1.0/8.8 | 1.8/15.9 | 2.9/25.7 | 4.2/37.2 | 6.7/59.3 | 9.1/80.5 | | |
| Recommended tool | |  | | | | | | | | | |
| Wood screw  | | Torque Nm/in lb | | 1.5/13.3 | 3/26.5 | 5/44.2 | 7.5/66.4 | 12/106.2 | | | |
| | Recommended tool |  | | | | | | | | | |

■ Shut-off clutch
 ■ Slip clutch
 ■ Direct drive

* With optional coupling-ring.
 ✪ With optional spring.

Ordering No. 4210 2316 01
 Ordering No. 4210 1831 00

The LUM pistol grip range comes in several different configurations:

- HR: Model with traditional-grip can be used with high grip when feed force is needed or with low grip for minimal reaction force.
- HRX: Model with balanced grip perfectly balanced for standard pistol grip applications.
- HRF: Balanced grip with multiple air inlets for flexible connection.
- The LUM32 model has the highest force to weight ratio amongst the pneumatic screwdrivers. It is also a tool with low reaction force and fast shut-off because of the position of the clutch.

RE reporting models are available, designated with suffix -RE.



| Model | Torque range soft joint | | Free speed r/min | Weight | | Length mm | CS distance mm | Air consumption at free speed | | Rec. hose size mm | Air inlet thread in | Ordering No. |
|------------------------------------|----------------------------|-----------|------------------------|--------|-----|--------------|-------------------|--|-----|----------------------------|------------------------------|--------------|
| | Nm | in lb | | kg | lb | | | l/s | cfm | | | |
| With trigger start | | | | | | | | | | | | |
| LUM22 HR3 | 0.6-3 | 5.3-26.5 | 2200 | 0.85 | 1.9 | 186 | 18 | 7.5 | 16 | 8 | 1/4 | 8431 0269 00 |
| LUM22 HR4 | 0.6-4 | 5.3-35.4 | 1650 | 0.85 | 1.9 | 186 | 18 | 7.5 | 16 | 8 | 1/4 | 8431 0269 02 |
| LUM22 HR4-RE | 0.6-4 | 5.3-35.4 | 1650 | 0.85 | 1.9 | 186 | 18 | 7.5 | 16 | 8 | 1/4 | 8431 0278 65 |
| LUM22 HR6 | 1.5-6.5 | 13.3-57.5 | 1150 | 0.85 | 1.9 | 186 | 18 | 7.5 | 16 | 8 | 1/4 | 8431 0269 01 |
| LUM22 HR6-RE | 1.5-6.5 | 13.3-57.5 | 1150 | 0.85 | 1.9 | 186 | 18 | 7.5 | 16 | 8 | 1/4 | 8431 0278 64 |
| LUM22 HR10 | 3.5-10 | 31-88.5 | 750 | 1 | 2.2 | 218 | 18 | 7.5 | 16 | 10 | 1/4 | 8431 0269 03 |
| LUM22 HR10-RE | 3.5-10 | 31-88.5 | 750 | 1 | 2.2 | 218 | 18 | 7.5 | 16 | 10 | 1/4 | 8431 0278 66 |
| LUM22 HR12 | 3.5-12.5 | 31-110.6 | 500 | 1 | 2.2 | 210 | 18 | 7.5 | 16 | 10 | 1/4 | 8431 0269 04 |
| LUM22 HR12-RE | 3.5-12.5 | 31-110.6 | 500 | 1 | 2.2 | 210 | 18 | 7.5 | 16 | 10 | 1/4 | 8431 0278 67 |
| LUM22 HR12-370 | 3.5-12.5 | 31-110.6 | 370 | 1 | 2.2 | 210 | 18 | 7.5 | 16 | 10 | 1/4 | 8431 0269 05 |
| LUM32 HR10 | 5-10 | 44.2-88.5 | 750 | 0.72 | 1.6 | 183 | 18.5 | 7.5 | 16 | 10 | 1/4 | 8431 0269 90 |
| LUM32 HR15 | 7.5-15.5 | 66-137.2 | 450 | 0.72 | 1.6 | 183 | 18.5 | 7.5 | 16 | 10 | 1/4 | 8431 0269 91 |
| With trigger and push start | | | | | | | | | | | | |
| LUM22 HR3-P | 0.6-3 | 5.3-26.5 | 2200 | 0.85 | 1.9 | 186 | 21 | 7.5 | 16 | 8 | 1/4 | 8431 0269 06 |
| LUM22 HR4-P | 0.6-4 | 5.3-35.4 | 1650 | 0.85 | 1.9 | 186 | 21 | 7.5 | 16 | 8 | 1/4 | 8431 0269 08 |
| LUM22 HR6-P | 1.5-6.5 | 13.3-57.5 | 1150 | 0.85 | 1.9 | 186 | 21 | 7.5 | 16 | 8 | 1/4 | 8431 0269 07 |
| LUM22 HR10-P | 3.5-10 | 31-88.5 | 750 | 1 | 2.2 | 218 | 21 | 7.5 | 16 | 10 | 1/4 | 8431 0269 09 |
| LUM22 HR12-P | 3.5-12.5 | 31-110.6 | 500 | 1 | 2.2 | 210 | 21 | 7.5 | 16 | 10 | 1/4 | 8431 0269 10 |
| LUM22 HR12-370-P | 3.5-12.5 | 31-110.6 | 370 | 1 | 2.2 | 210 | 21 | 7.5 | 16 | 10 | 1/4 | 8431 0269 11 |

Continued...

| Model | Torque range soft joint | | Free speed r/min | Weight | | Length mm | CS distance mm | Air consumption at free speed | | Rec. hose size mm | Air inlet thread in | Ordering No. |
|---|----------------------------|-----------|------------------------|--------|-----|--------------|-------------------|--|-----|----------------------------|------------------------------|--------------|
| | Nm | in lb | | kg | lb | | | l/s | cfm | | | |
| Balanced grip models with trigger start | | | | | | | | | | | | |
| LUM12 HRX1 | 0.6-1.8 | 5.3-15.9 | 2300 | 0.65 | 1.4 | 176 | 15 | 6 | 13 | 6 | 1/8 | 8431 0278 58 |
| LUM12 HRX2 | 0.6-2.5 | 5.3-22.1 | 1650 | 0.65 | 1.4 | 176 | 16 | 6 | 13 | 6 | 1/8 | 8431 0278 56 |
| LUM12 HRX3 | 0.4-3.5 | 5.3-31.9 | 1150 | 0.7 | 1.5 | 186 | 16 | 6 | 13 | 6 | 1/8 | 8431 0278 54 |
| LUM12 HRX3-RE | 0.4-3.5 | 3.5-31.9 | 1150 | 0.7 | 1.5 | 186 | 16 | 6 | 13 | 6 | 1/8 | 8431 0278 55 |
| LUM12 HRX5 | 0.4-5 | 3.5-44.2 | 850 | 0.7 | 1.5 | 186 | 16 | 6 | 13 | 6 | 1/8 | 8431 0278 51 |
| LUM12 HRX5-RE | 0.4-5 | 3.5-44.2 | 850 | 0.7 | 1.5 | 186 | 16 | 6 | 13 | 6 | 1/8 | 8431 0278 53 |
| LUM12 HRX5-350 | 0.4-5 | 3.5-44.2 | 350 | 0.7 | 1.5 | 186 | 16 | 6 | 13 | 6 | 1/8 | 8431 0278 48 |
| LUM12 HRX5-350-RE | 0.4-5 | 3.5-44.2 | 350 | 0.7 | 1.5 | 186 | 16 | 6 | 13 | 6 | 1/8 | 8431 0278 49 |
| LUM12 HRX8 | 1.5-8 | 13.3-70.8 | 500 | 0.7 | 1.5 | 186 | 16 | 6 | 13 | 6 | 1/8 | 8431 0278 60 |
| LUM12 HRX8-110 | 1.5-8 | 13.3-70.8 | 110 | 0.7 | 1.5 | 196 | 16 | 6 | 13 | 6 | 1/8 | 8431 0280 27 |
| LUM12 HRX8-250 | 1.5-8 | 13.3-70.8 | 250 | 0.7 | 1.5 | 186 | 16 | 6 | 13 | 6 | 1/8 | 8431 0278 69 |
| LUM12 HRX8-RE | 1.5-8 | 13.3-70.8 | 500 | 0.7 | 1.5 | 186 | 16 | 6 | 13 | 6 | 1/8 | 8431 0278 61 |
| LUM22 HRX2 | 1.2-2 | 10.6-17.7 | 4500 | 0.9 | 2 | 187 | 18 | 9 | 19 | 8 | 1/4 | 8431 0269 29 |
| LUM22 HRX2-3200 | 1.1-2.6 | 9.7-23 | 3200 | 0.9 | 2 | 187 | 18 | 9 | 19 | 8 | 1/4 | 8431 0278 85 |
| LUM22 HRX3 | 0.6-3 | 5.3-26.5 | 2250 | 0.9 | 2 | 187 | 18 | 9 | 19 | 8 | 1/4 | 8431 0269 22 |
| LUM22 HRX3.5 | 0.6-3.5 | 5.3-29.2 | 2250 | 0.9 | 2 | 187 | 18 | 9 | 19 | 8 | 1/4 | 8431 0269 99 |
| LUM22 HRX4 | 0.6-4 | 5.3-35.4 | 1650 | 0.9 | 2 | 187 | 18 | 9 | 19 | 8 | 1/4 | 8431 0269 20 |
| LUM22 HRX6 | 1.5-6.5 | 13.3-57.5 | 1100 | 0.95 | 2.1 | 197 | 18 | 9 | 19 | 8 | 1/4 | 8431 0269 21 |
| LUM22 HRX6-RE | 1.5-6.5 | 13.3-57.5 | 1100 | 0.95 | 2.1 | 197 | 18 | 9 | 19 | 8 | 1/4 | 8431 0278 71 |
| LUM22 HRX10 | 3.5-10 | 31-88.5 | 800 | 1.1 | 2.4 | 219 | 18 | 9 | 19 | 10 | 1/4 | 8431 0269 23 |
| LUM22 HRX10-RE | 3.5-10 | 31-88.5 | 800 | 1.1 | 2.4 | 219 | 18 | 9 | 19 | 10 | 1/4 | 8431 0278 73 |
| LUM22 HRX11-220 | 3.5-12.5 | 31-110.6 | 220 | 1.15 | 2.5 | 229 | 18 | 9 | 19 | 10 | 1/4 | 8431 0282 20 |
| LUM22 HRX12 | 3.5-12.5 | 31-110.6 | 500 | 1.1 | 2.4 | 211 | 18 | 9 | 19 | 10 | 1/4 | 8431 0269 24 |
| LUM22 HRX12-RE | 3.5-12.5 | 31-110.6 | 500 | 1.1 | 2.4 | 211 | 18 | 9 | 19 | 10 | 1/4 | 8431 0278 74 |
| LUM22 HRX12-50 | 3.5-12.5 | 31-110.6 | 50 | 1.15 | 2.5 | 229 | 18 | 9 | 19 | 10 | 1/4 | 8431 0280 26 |
| LUM22 HRX12-120 | 3.5-12.5 | 31-110.6 | 120 | 1.15 | 2.5 | 229 | 18 | 9 | 19 | 10 | 1/4 | 8431 0280 28 |
| LUM22 HRX12-370 | 3.5-12.5 | 31-110.6 | 370 | 1.1 | 2.4 | 211 | 18 | 9 | 19 | 10 | 1/4 | 8431 0269 25 |
| LUM22 HRX12-370-RE | 3.5-12.5 | 31-110.6 | 370 | 1.1 | 2.4 | 211 | 18 | 9 | 19 | 10 | 1/4 | 8431 0278 75 |
| LUM22 HRX26 ^a | 3-26 | 26.6-230 | 220 | 1.2 | 2.6 | 233 | 18 | 9 | 19 | 10 | 1/4 | 8431 0269 39 |
| Multiple air inlet models with trigger start | | | | | | | | | | | | |
| LUM12 HRF2 | 0.6-2.5 | 5.3-22.1 | 1650 | 0.65 | 1.4 | 190 | 16 | 6 | 13 | 6 | 1/8 | 8431 0269 31 |
| LUM12 HRF3 | 0.4-3.6 | 3.5-31.9 | 1150 | 0.7 | 1.5 | 200 | 16 | 6 | 13 | 6 | 1/8 | 8431 0269 32 |
| LUM12 HRF5 | 0.4-5 | 3.5-44.2 | 850 | 0.7 | 1.5 | 200 | 16 | 6 | 13 | 6 | 1/8 | 8431 0269 33 |
| LUM12 HRF8 | 1.5-8 | 13.3-70.8 | 500 | 0.7 | 1.5 | 200 | 16 | 6 | 13 | 6 | 1/8 | 8431 0269 34 |

^a 1/4" square drive.

All models: Are reversible and have quick change chuck.

All data at an air pressure of 6.3 bar.

For operator comfort a support handle is recommended for high torque, see Optional Accessories.

Pistol Grip Models

Direct Drive

The LUD and LUF pistol grip range comes in several different configurations:

- HR/HRD: Model with traditional-grip can be used with high grip when feed force is needed or with low grip for minimal reaction force.
- HRX: Models with balanced grip are perfectly balanced for standard pistol grip applications.



| Model | Torque range soft joint | | Free speed r/min | Weight | | Length mm | CS distance mm | Air consumption at free speed | | Rec. hose size mm | Air inlet thread in | Ordering No. |
|--|-------------------------|------------|------------------|--------|-----|-----------|----------------|-------------------------------|-----|-------------------|---------------------|--------------|
| | Nm | in lb | | kg | lb | | | l/s | cfm | | | |
| With trigger start | | | | | | | | | | | | |
| LUD12 HRX2 | 1-2.5 | 8.8-22.1 | 1600 | 0.5 | 1.1 | 115 | 16 | 6.5 | 14 | 8 | 1/8 | 8431 0278 77 |
| LUD12 HRX5 | 2-5 | 17.7-44.2 | 850 | 0.5 | 1.1 | 125 | 16 | 6.5 | 14 | 8 | 1/8 | 8431 0278 78 |
| LUD12 HRX8 | 3.5-8 | 31.0-70.8 | 500 | 0.5 | 1.1 | 125 | 16 | 6.5 | 14 | 8 | 1/8 | 8431 0278 79 |
| LUD22 HR3 | 1.5-2.8 | 13.3-24.8 | 3600 | 0.65 | 1.4 | 125 | 18 | 8 | 17 | 8 | 1/4 | 8431 0269 17 |
| LUD22 HR5 | 2.8-5.5 | 24.8-48.7 | 1650 | 0.65 | 1.4 | 125 | 18 | 8 | 17 | 8 | 1/4 | 8431 0269 18 |
| LUD22 HR12 | 5-12 | 44.2-106.2 | 750 | 0.75 | 1.7 | 143 | 18 | 8 | 17 | 8 | 1/4 | 8431 0269 19 |
| LUF34 HRD04 | 8.0-18.0 | 71-160 | 440 | 1.2 | 2.6 | 212 | 20 | 9 | 19 | 10 | 1/4 | 8431 0311 22 |
| LUF34 HRD08 | 8.0-11.0 | 71-97 | 750 | 1.2 | 2.6 | 212 | 20 | 9 | 19 | 10 | 1/4 | 8431 0311 24 |
| LUF34 HRD16 | 4.0-8.0 | 35-71 | 1600 | 0.9 | 2.0 | 179 | 20 | 9 | 19 | 10 | 1/4 | 8431 0311 26 |
| Reversible drill, taper and screwdriver | | | | | | | | | | | | |
| COMBI22 HR2 | 2.0-2.7 | 18-24 | 3600 | 0.9 | 2.0 | 205 | 20 | 7 | 15 | 8 | 1/4 | 8431 0255 89 |
| COMBI22 HR5 | 2.7-5.7 | 24-50 | 1600 | 0.9 | 2.0 | 205 | 20 | 7 | 15 | 8 | 1/4 | 8431 0255 80 |
| COMBI22 HR10 | 5.0-10.0 | 44-89 | 800 | 1.1 | 2.4 | 240 | 20 | 7 | 15 | 8 | 1/4 | 8431 0255 62 |
| COMBI34 HR04 | 8.0-18.0 | 71-160 | 400 | 1.5 | 3.3 | 228 | 20 | 9 | 19 | 10 | 1/4 | 8431 0311 32 |
| COMBI34 HR08 | 8.0-11.0 | 71-97 | 750 | 1.3 | 2.9 | 218 | 20 | 9 | 19 | 10 | 1/4 | 8431 0311 34 |
| COMBI34 HR16 | 4.0-8.0 | 35-71 | 1600 | 1.0 | 2.2 | 179 | 20 | 9 | 19 | 10 | 1/4 | 8431 0311 36 |

All models: Are reversible.
 Are equipped with a 1/4" female hexagon drive for bits.
 Combi-tools are delivered with drill chuck and 1/4" female hex drive for bits.
 Torque range is reached by adjusting the air pressure between minimum 3 bar and maximum 6 bar.

The TWIST and LUF pistol grip range comes in several different configurations:

- HR: Model with traditional-grip can be used with high grip when feed force is needed or with low grip for minimal reaction force.
- HRX: models with balanced grip are perfectly balanced for standard pistol grip applications.
- HRF: Balanced grip with multiple air inlets for flexible connection.



| Model | Torque range soft joint | | Free speed r/min | Weight | | Length mm | CS distance mm | Air consumption at free speed | | Rec. hose size mm | Air inlet thread in | Ordering No. |
|--|-------------------------|------------|------------------|--------|-----|-----------|----------------|-------------------------------|-----|-------------------|---------------------|--------------|
| | Nm | in lb | | kg | lb | | | l/s | cfm | | | |
| With trigger and push start | | | | | | | | | | | | |
| TWIST12 HRX2 | 0.6-2.4 | 5.3-21.2 | 1650 | 0.65 | 1.4 | 176 | 15 | 6.5 | 14 | 6 | 1/8 | 8431 0278 40 |
| TWIST12 HRX3 | 0.6-3.5 | 5.3-31.0 | 1150 | 0.65 | 1.4 | 186 | 15 | 6.5 | 14 | 6 | 1/8 | 8431 0278 39 |
| TWIST12 HRX4 | 0.5-4.4 | 4.4-38.9 | 800 | 0.65 | 1.4 | 186 | 15 | 6.5 | 14 | 6 | 1/8 | 8431 0278 38 |
| TWIST22 HRX7 | 1.5-7.5 | 13.3-66.4 | 1100 | 1.05 | 2.3 | 205 | 15 | 9 | 19 | 8 | 1/4 | 8431 0269 26 |
| TWIST22 HRX10 | 1.5-10 | 13.3-88.5 | 750 | 1.1 | 2.4 | 205 | 15 | 9 | 19 | 8 | 1/4 | 8431 0269 27 |
| TWIST22 HRX12 | 5-12 | 44.2-106.2 | 500 | 1.05 | 2.3 | 205 | 15 | 9 | 19 | 8 | 1/4 | 8431 0269 28 |
| TWIST22 HR3 | 1.0-3.5 | 8.9-31 | 2100 | 0.95 | 2.1 | 195 | 15 | 8 | 17 | 8 | 1/4 | 8431 0278 86 |
| TWIST22 HR6 | 2.2-6.5 | 19.5-57.5 | 1600 | 0.95 | 2.1 | 195 | 15 | 8 | 17 | 8 | 1/4 | 8431 0269 70 |
| TWIST22 HR7 | 1.5-7.5 | 13.3-66.4 | 1150 | 0.95 | 2.1 | 195 | 15 | 8 | 17 | 8 | 1/4 | 8431 0269 14 |
| TWIST22 HR10 | 1.5-10.0 | 13.3-88.5 | 750 | 1 | 2.2 | 205 | 15 | 8 | 17 | 8 | 1/4 | 8431 0269 15 |
| TWIST22 HR12 | 5.0-12.0 | 44.2-106.2 | 500 | 1 | 2.2 | 195 | 15 | 8 | 17 | 8 | 1/4 | 8431 0269 16 |
| LUF34 HR04 | 3.0-17.0 | 27.0-150.0 | 440 | 1.4 | 3.1 | 265 | 21 | 9.5 | 19 | 8 | 1/4 | 8431 0311 05 |
| LUF34 HR08 | 2.0-15.0 | 18.0-133.0 | 750 | 1.4 | 3.1 | 265 | 21 | 9.5 | 19 | 8 | 1/4 | 8431 0311 09 |
| LUF34 HR16 | 3.0-12.0 | 27.0-107.0 | 1600 | 1.4 | 3.1 | 265 | 21 | 9.5 | 19 | 8 | 1/4 | 8431 0311 17 |
| Multiple air inlet models and air-on-top models with trigger start and push start | | | | | | | | | | | | |
| TWIST12 HRF4 | 0.5-4.4 | 4.4-38.9 | 850 | 0.7 | 1.5 | 200 | 15 | 6.5 | 14 | 6 | 1/8 | 8431 0269 40 |
| TWIST HRF08 ^a | 1.5-7.5 | 13.0-66.0 | 800 | 1.2 | 2.6 | 212 | 25 | 7 | 15 | 8 | 1/4 | 8431 0252 42 |
| TWIST HRF16 ^a | 2.2-6.5 | 20.0-58.0 | 1600 | 1.2 | 2.6 | 212 | 25 | 7 | 15 | 8 | 1/4 | 8431 0252 44 |

^a Only air-on-top models.

All models: Are reversible.

Are equipped with a 1/4" female hexagon drive for bits.

Have quick change chuck.

All data at an air pressure of 6.3 bar.

Straight screwdrivers should be used with a torque arm for best ergonomics.

LUM straight screwdrivers come in two different configurations:

- PR: Model with push-to-start function and reverse button.
- SR: Model with lever start function and reverse ring.

RE reporting conversion kits are available for SR models, see accessory page.

Soft stop options are available, designated with the suffix -SS.

LUM12 PR



LUM12 SR



| Model | Torque range soft joint | | Free speed r/min | Weight | | Length mm | CS distance mm | Air consumption at free speed | | Rec. hose size mm | Air inlet thread in | Ordering No. |
|---|----------------------------|-----------|------------------------|--------|-----|--------------|----------------------|--|-----|----------------------------|------------------------------|--------------|
| | Nm | in lb | | kg | lb | | | l/s | cfm | | | |
| With push start and button reverse | | | | | | | | | | | | |
| LUM10 PR03 | 0.1-1.5 | 0.8-13 | 300 | 0.4 | 0.9 | 206 | 15 | 3 | 6 | 6 | 1/8 | 8431 0146 05 |
| LUM10 PR05 | 0.1-1.5 | 0.8-13 | 460 | 0.4 | 0.9 | 206 | 15 | 3 | 6 | 6 | 1/8 | 8431 0146 09 |
| LUM10 PR12 | 0.1-1.1 | 0.8-10 | 1200 | 0.4 | 0.9 | 196 | 15 | 3 | 6 | 6 | 1/8 | 8431 0146 17 |
| LUM10 PR21 | 0.1-0.7 | 0.8-6 | 2000 | 0.4 | 0.9 | 196 | 15 | 3 | 6 | 6 | 1/8 | 8431 0146 25 |
| LUM12 PR1 | 0.6-1.6 | 5.3-14.2 | 1900 | 0.55 | 1.2 | 195 | 17 | 4.5 | 10 | 6 | 1/8 | 8431 0278 29 |
| LUM12 PR2 | 0.4-2.3 | 3.5-20.4 | 1450 | 0.55 | 1.2 | 195 | 17 | 4.5 | 10 | 6 | 1/8 | 8431 0278 27 |
| LUM12 PR3 | 0.4-3.2 | 3.5-28.3 | 1000 | 0.55 | 1.2 | 195 | 17 | 4.5 | 10 | 6 | 1/8 | 8431 0278 26 |
| LUM12 PR4 | 0.4-4.2 | 3.5-37.2 | 750 | 0.55 | 1.2 | 195 | 17 | 4.5 | 10 | 6 | 1/8 | 8431 0278 25 |
| LUM12 PR5 | 0.4-5 | 3.5-44.2 | 450 | 0.55 | 1.2 | 195 | 20 | 4.5 | 10 | 6 | 1/8 | 8431 0278 30 |
| LUM22 PR2-3500 | 1.1-2.5 | 9.7-22.1 | 3500 | 0.75 | 1.7 | 211 | 20 | 7 | 15 | 8 | 1/4 | 8431 0278 89 |
| LUM22 PR3 | 0.6-3.2 | 5.3-28.3 | 2100 | 0.75 | 1.7 | 211 | 20 | 7 | 15 | 8 | 1/4 | 8431 0269 61 |
| LUM22 PR4 | 0.5-4.0 | 4.4-35.4 | 1600 | 0.75 | 1.7 | 211 | 20 | 7 | 15 | 8 | 1/4 | 8431 0269 55 |
| LUM22 PR4-2300 | 0.7-4.5 | 5.9-38.2 | 2300 | 0.75 | 1.7 | 211 | 20 | 7 | 15 | 8 | 1/4 | 8431 0278 81 |
| LUM22 PR5-260 | 0.4-5.0 | 3.5-44.2 | 260 | 0.75 | 1.7 | 211 | 20 | 7 | 15 | 8 | 1/4 | 8431 0269 62 |
| LUM22 PR5-350 | 0.4-5.0 | 3.5-44.2 | 350 | 0.75 | 1.7 | 211 | 20 | 7 | 15 | 8 | 1/4 | 8431 0269 60 |
| LUM22 PR6 | 1.5-6.0 | 13.3-53.1 | 1000 | 0.75 | 1.7 | 211 | 20 | 7 | 15 | 8 | 1/4 | 8431 0269 56 |
| LUM22 PR8-1100 | 1.5-8.0 | 13.3-70.8 | 1100 | 0.9 | 2.0 | 224 | 20 | 7 | 15 | 8 | 1/4 | 8431 0278 88 |
| LUM22 PR10 | 3.5-10.0 | 31-88.5 | 700 | 0.95 | 2.1 | 232 | 22 | 7 | 15 | 8 | 1/4 | 8431 0269 58 |
| LUM22 PR12 | 3.5-12.5 | 31-110.6 | 450 | 0.9 | 2.0 | 224 | 22 | 7 | 15 | 8 | 1/4 | 8431 0269 57 |
| LUM22 PR12-350 | 3.5-12.5 | 31-110.6 | 350 | 0.95 | 2.1 | 224 | 22 | 7 | 15 | 8 | 1/4 | 8431 0269 59 |
| LUM22 PR12-850 | 3.5-12.0 | 31-106.2 | 850 | 1 | 2.2 | 246 | 22 | 8.5 | 15 | 8 | 1/4 | 8431 0278 80 |
| With lever start and reverse ring | | | | | | | | | | | | |
| LUM12 SR1 | 0.6-1.8 | 5.3-15.9 | 2200 | 0.6 | 1.3 | 217 | 17 | 6 | 13 | 6 | 1/8 | 8431 0278 35 |
| LUM12 SR2 | 0.5-2.5 | 4.4-22.1 | 1700 | 0.6 | 1.3 | 217 | 17 | 6 | 13 | 6 | 1/8 | 8431 0278 34 |
| LUM12 SR3 | 0.4-3.5 | 3.5-31 | 1200 | 0.6 | 1.3 | 217 | 17 | 6 | 13 | 6 | 1/8 | 8431 0278 33 |
| LUM12 SR4 | 0.4-4.5 | 3.5-39.8 | 850 | 0.6 | 1.3 | 217 | 17 | 6 | 13 | 6 | 1/8 | 8431 0278 32 |
| LUM22 SR3 | 0.6-3.2 | 5.3-28.3 | 1950 | 0.8 | 1.8 | 239 | 20 | 7 | 15 | 8 | 1/4 | 8431 0269 44 |
| LUM22 SR4 | 0.6-4 | 5.3-35.4 | 1500 | 0.8 | 1.8 | 239 | 20 | 7 | 15 | 8 | 1/4 | 8431 0269 46 |
| LUM22 SR5-300 | 0.4-5 | 3.5-44.2 | 300 | 0.8 | 1.8 | 239 | 20 | 7 | 15 | 8 | 1/4 | 8431 0269 51 |
| LUM22 SR6 | 1.5-6 | 13.3-53.1 | 1000 | 0.85 | 1.9 | 239 | 20 | 7 | 15 | 8 | 1/4 | 8431 0269 47 |
| LUM22 SR10 | 3.5-10 | 31-88.5 | 700 | 1 | 2.2 | 260 | 22 | 7 | 15 | 8 | 1/4 | 8431 0269 49 |
| LUM22 SR12 | 3.5-12.5 | 31-110.6 | 430 | 0.95 | 2.1 | 252 | 22 | 7 | 15 | 8 | 1/4 | 8431 0269 48 |
| LUM22 SR12-300 | 3.5-12.5 | 31-110.6 | 300 | 1 | 2.2 | 252 | 22 | 7 | 15 | 8 | 1/4 | 8431 0269 50 |

All LUM10/12/22 SR/PR: ESD approved
All data at an air pressure of 6.3 bar.

Straight screwdrivers should be used with a torque arm for best ergonomics

The TWIST straight screwdrivers come in two different configurations:

- PR: Model with push to start function and reverse button
- SR: Model with lever start function and reverse ring.

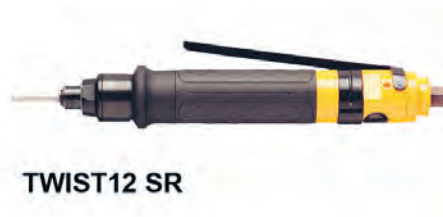

| Model | Torque range soft joint | | Free speed r/min | Weight | | Length mm | CS distance mm | Air consumption at free speed | | Rec. hose size mm | Air inlet thread in | Ordering No. |
|---|-------------------------|-----------|------------------|--------|-----|-----------|----------------|-------------------------------|-----|-------------------|---------------------|--------------|
| | Nm | in lb | | kg | lb | | | l/s | cfm | | | |
| With lever start and reverse ring | | | | | | | | | | | | |
| TWIST12 SR4 | 0.5-4.2 | 4.4-37.2 | 1100 | 0.65 | 1.4 | 225 | 15 | 6 | 13 | 6 | 1/8 | 8431 0278 43 |
| TWIST22 SR6 | 1.5-6.0 | 13.3-53.1 | 1500 | 0.85 | 1.9 | 239 | 15 | 7 | 15 | 8 | 1/8 | 8431 0269 52 |
| TWIST22 SR10 | 1.5-10.0 | 13.3-88.5 | 700 | 0.9 | 2.0 | 246 | 15 | 7 | 15 | 8 | 1/8 | 8431 0269 53 |
| With push start and reverse button | | | | | | | | | | | | |
| TWIST22 PR4-2300 | 1.0-4.0 | 8.9-35.4 | 2300 | 0.75 | 1.7 | 242 | 15 | 7 | 15 | 8 | 1/4 | 8431 0278 92 |
| TWIST22 PR6 | 2.2-6.5 | 19.5-57.5 | 1600 | 0.75 | 1.7 | 211 | 15 | 7 | 15 | 8 | 1/4 | 8431 0278 91 |
| TWIST22 PR7 | 1.5-7.5 | 13.3-66.4 | 1100 | 0.75 | 1.7 | 211 | 15 | 7 | 15 | 8 | 1/4 | 8431 0278 90 |

All data at an air pressure of 6.3 bar.

LTV angle screwdriver models have a fast, accurate shut-off clutch and are designed for durability.

- Slim design of the angle head allows good access in limited spaces and awkward positions.
- Spiral cut gears give high accuracy.

RE reporting conversion kits are available for LTV screwdriver models. For kit, see accessory page.



LTV009

| Model | Torque range soft joint | | Free speed r/min | Weight | | Length mm | Angle head height mm | Angle head center to side mm | Air consumption at free speed | | Rec. hose size mm | Air inlet thread in | Ordering No. |
|---|----------------------------|-----------|------------------------|--------|-----|--------------|-------------------------------|--|--|-----|----------------------------|------------------------------|--------------|
| | Nm | in lb | | kg | lb | | | | l/s | cfm | | | |
| 1/4" female hexagon drive for bits | | | | | | | | | | | | | |
| LTV009 R05-42 | 0.4-5 | 3.5-44.2 | 850 | 0.7 | 1.5 | 266 | 25 | 9 | 6 | 13 | 6 | 1/8 | 8431 0278 07 |
| LTV009 R07-42 | 1.1-7 | 9.7-61.9 | 500 | 0.7 | 1.5 | 266 | 25 | 9 | 6 | 13 | 6 | 1/8 | 8431 0278 10 |
| LTV009 R07-42-SH | 1.1-7 | 9.7-61.9 | 500 | 0.7 | 1.5 | 243 | 25 | 9 | 6 | 13 | 6 | 1/8 | 8431 0279 29 |
| LTV009 R09-42 | 1.3-9 | 11.5-79.6 | 430 | 0.7 | 1.5 | 266 | 28.5 | 11 | 6 | 13 | 6 | 1/8 | 8431 0278 15 |
| LTV009 R11-42 | 1.3-11 | 11.5-97.3 | 320 | 0.8 | 1.8 | 266 | 28.5 | 11 | 6 | 13 | 6 | 1/8 | 8431 0278 21 |
| LTV009 R035-42 | 0.4-3.5 | 3.5-31 | 1100 | 0.7 | 1.5 | 266 | 25 | 9 | 6 | 13 | 6 | 1/8 | 8431 0278 04 |
| LTV19 R15-42 | 6-15 | 54-133 | 360 | 1.1 | 2.4 | 309 | 36 | 11 | 7 | 15 | 8 | 1/4 | 8431 0279 35 |
| 1/4" square drive for sockets | | | | | | | | | | | | | |
| LTV009 R05-6 | 0.4-5 | 3.5-44.2 | 850 | 0.7 | 1.5 | 266 | 25 | 9 | 6 | 13 | 6 | 1/8 | 8431 0278 08 |
| LTV009 R07-6 | 1.1-7 | 9.7-61.9 | 500 | 0.7 | 1.5 | 266 | 25 | 9 | 6 | 13 | 6 | 1/8 | 8431 0278 11 |
| LTV009 R07-6-SH | 1.1-7 | 9.7-61.9 | 500 | 0.7 | 1.5 | 243 | 25 | 9 | 6 | 13 | 6 | 1/8 | 8431 0279 28 |
| LTV009 R07-6-230 | 0.3-7 | 2.6-61.9 | 230 | 0.8 | 1.8 | 266 | 25 | 9 | 6 | 13 | 6 | 1/8 | 8431 0279 18 |
| LTV009 R09-6 | 1.3-9 | 11.5-79.6 | 430 | 0.7 | 1.5 | 266 | 28.5 | 11 | 6 | 13 | 6 | 1/8 | 8431 0278 17 |
| LTV009 R11-6-200 | 1.3-11 | 11.5-97.3 | 200 | 0.7 | 1.5 | 266 | 28.5 | 11 | 6 | 13 | 6 | 1/8 | 8431 0278 24 |
| LTV009 R11-6-200-B | 1.3-11 | 11.5-97.3 | 200 | 0.8 | 1.8 | 266 | 27.6 | 11 | 6 | 13 | 6 | 1/8 | 8431 0278 31 |
| LTV009 R11-6 | 1.3-11 | 11.5-97.3 | 320 | 0.8 | 1.8 | 266 | 28.5 | 11 | 6 | 13 | 6 | 1/8 | 8431 0278 22 |
| LTV009 R035-6 | 0.4-3.5 | 3.5-31 | 1100 | 0.7 | 1.5 | 266 | 25 | 9 | 6 | 13 | 6 | 1/8 | 8431 0278 05 |
| LTV19 R15-6 | 6-15 | 54-133 | 360 | 1.1 | 2.4 | 309 | 31 | 11 | 7 | 15 | 8 | 1/4 | 8431 0279 34 |
| 3/8" square drive for sockets | | | | | | | | | | | | | |
| LTV009 R03-10 | 0.7-3 | 6.2-26.5 | 1400 | 0.7 | 1.5 | 266 | 25 | 9 | 6 | 13 | 6 | 1/8 | 8431 0278 23 |
| LTV009 R09-10 | 1.3-9 | 11.5-79.6 | 430 | 0.7 | 1.5 | 266 | 28.5 | 11 | 6 | 13 | 6 | 1/8 | 8431 0278 13 |
| LTV009 R11-10 | 1.3-11 | 11.5-97.3 | 320 | 0.8 | 1.8 | 266 | 28.5 | 11 | 6 | 13 | 6 | 1/8 | 8431 0278 20 |
| LTV19 R15-10 | 6-15 | 54-133 | 360 | 1.1 | 2.4 | 309 | 31 | 11 | 7 | 15 | 8 | 1/4 | 8431 0279 36 |
| 1/4" quick change chuck | | | | | | | | | | | | | |
| LTV009 R05-Q | 0.4-5 | 3.5-44.2 | 850 | 0.7 | 1.5 | 266 | 25 | 9 | 6 | 13 | 6 | 1/8 | 8431 0278 06 |
| LTV009 R07-Q | 1.1-7 | 9.7-61.9 | 500 | 0.7 | 1.5 | 266 | 25 | 9 | 6 | 13 | 6 | 1/8 | 8431 0278 09 |
| LTV009 R07-Q-SH | 1.1-7 | 9.7-61.9 | 500 | 0.7 | 1.5 | 243 | 25 | 9 | 6 | 13 | 6 | 1/8 | 8431 0279 30 |
| LTV009 R09-Q | 1.3-9 | 11.5-79.6 | 430 | 0.7 | 1.5 | 266 | 28.5 | 11 | 6 | 13 | 6 | 1/8 | 8431 0278 12 |
| LTV009 R11-Q | 1.3-11 | 11.5-97.3 | 320 | 0.8 | 1.8 | 266 | 28.5 | 11 | 6 | 13 | 6 | 1/8 | 8431 0278 19 |
| LTV009 R025-Q | 0.6-2.5 | 5.3-22.1 | 1650 | 0.7 | 1.5 | 266 | 25 | 9 | 6 | 13 | 6 | 1/8 | 8431 0278 00 |
| LTV009 R035-Q | 0.4-3.5 | 3.5-31 | 1100 | 0.7 | 1.5 | 266 | 25 | 9 | 6 | 13 | 6 | 1/8 | 8431 0278 03 |
| LTV19 R15-Q | 6-15 | 54-133 | 360 | 1.1 | 2.4 | 309 | 45 | 11 | 7 | 15 | 8 | 1/4 | 8431 0279 37 |
| Flush socket | | | | | | | | | | | | | |
| LTV009 R12-FS-10 | 1.5-8 | 13.3-70.8 | 340 | 1.1 | 2.4 | 261 | 23.5 | 13.5 | 6 | 13 | 6 | 1/8 | 8431 0632 11 |

- All models:**
- Are reversible.
 - All data at an air pressure of 6.3 bar.
 - Are ESD approved

Accessories Included

EXHAUST HOSE

Included with straight and air-on-top models

CLUTCH ADJUSTMENT KEY

Included with all shut-off and slip clutch tools



Clutch adjustment key

Optional Accessories



| Designation | Exhaust hose | Support handle | ESD hose | Torque arms adapters | Installation proposal | ESD approved pistol handle |
|-------------------|--------------|----------------|--------------|----------------------|-----------------------|----------------------------|
| LUM12 HRX/HRF | 4210 2052 00 | 4110 1355 92 | 8202 0501 06 | – | 8202 1180 67 | 4210 3616 04 |
| LUM22 HR 3, 4, 6 | 4210 2052 00 | 4110 1355 92 | 8202 0501 10 | – | 8202 1180 77 | 4210 4337 04 |
| LUM22 HR 10, 12 | 4210 2052 00 | 4110 1355 93 | 8202 0501 10 | – | 8202 1180 77 | 4210 4337 04 |
| LUM22 HRX 3, 4, 6 | 4210 2052 00 | 4110 1355 92 | 8202 0501 10 | – | 8202 1180 77 | 4210 3616 04 |
| LUM12 SR | 4210 2052 00 | – | 8202 0501 06 | 4390 1735 52 | 8202 1180 67 | – |
| LUM12 PR | 4210 2052 00 | – | 8202 0501 06 | 4390 1735 53 | 8202 1180 67 | – |
| LUM22 SR | 4210 2053 00 | – | 8202 0501 10 | 4390 1735 51 | 8202 1180 77 | – |
| LUM22 PR | 4210 2053 00 | – | 8202 0501 10 | 4390 1735 54 | 8202 1180 77 | – |
| LTV009 | 4210 2052 00 | – | 8202 0501 06 | – | 8202 1180 67 | – |
| LUM32 HR | 4210 2052 00 | 4110 1355 94 | 8202 0501 10 | – | 8202 1180 77 | 4210 4337 04 |
| LUF34 | 4210 2053 00 | 4110 1355 82 | 8202 0501 10 | – | 8202 1180 77 | – |

| Model | Ordering No. |
|---|--------------|
| Threaded clutch houses | |
| LUM12 PR/SR 1, 2, 3, 4 | 4210 4386 04 |
| LUM12 HRX/HRF 1, 3, 5, 8 | 4210 4386 04 |
| LUM22 HRX/HR 2, 3, 4, 6 | 4210 4386 04 |
| LUM22 HRX/HR 10, 12 | 4210 4392 03 |
| LUM22 SR/PR 3, 4, 5, 6, 8 | 4210 4383 04 |
| LUM22 SR/PR 10, 12 | 4210 4383 03 |
| Angle head covers | |
| LTV009 R025-R07 | 4210 4115 00 |
| LTV009 R08-R11 | 4210 4116 00 |
| Protective covers | |
| LUM22/32 HR | 4210 3150 00 |
| LUM22 HRX | 4210 3151 00 |
| LUM12 HRX | 4210 4642 00 |
| Threaded fronts | |
| LUM 32 HR10, 15 | 4210 4252 90 |
| Suspension yoke for LTV009 | 4210 4461 80 |
| Quick change chuck kit , extra wide diameter for easy handling | 4210 2326 91 |
| Angle-head for LTV009 R03/08/09/11, 90° hex drive magnetic bit holder ^a | 4210 3857 91 |



Suspension yoke



Quick change chuck kit



Angle-head for LTV009

^a Substitute for 4210 3857 XX angle heads.

RE-CONVERSION KITS

| Model | Ordering No. |
|-----------|--------------|
| LUM12 HRF | 4210 3624 99 |
| LUM12 SR | 4210 4137 90 |
| LUM22 SR | 4210 2057 80 |
| LTV009 | 4210 4137 90 |

Productivity Kits

| Model | Max air flow | Hose 16.4 ft | Coupling | Lubrication | Ordering No. |
|--------------------------------|--------------|--------------|--------------|-------------|--------------|
| MIDI Optimizer F/R EQ08US-C06 | 12 cfm | Cablair 06 | ErgoQIC 08US | No | 8202 0850 21 |
| MIDI Optimizer F/RD EQ08US-C06 | 19 cfm | Cablair 06 | ErgoQIC 08US | Yes | 8202 0850 22 |
| MIDI Optimizer F/RD EQ08US-C08 | 19 cfm | Cablair 08 | ErgoQIC 08US | Yes | 8202 0850 23 |
| MIDI Optimizer F/R EQ08US-C08 | 19 cfm | Cablair 08 | ErgoQIC 08US | No | 8202 0850 24 |



Service Kits

The spare parts included in the service kits cover a normal overhaul of your tool. Always have them available for a fast and economical repair.

Main parts included:

- Vane kit
- Motor bearings
- Gaskets
- O-rings
- Circlips
- Pins etc.

| Model | Ordering No. |
|---------------------------|--------------|
| LUM10 PR | 4081 0070 90 |
| LUM12 HRX, HRF | 4081 0247 90 |
| LUM12 SR | 4081 0254 90 |
| LUM12 PR | 4081 0250 90 |
| LUM22 HR/HRX 3, 4, 6, 12 | 4081 0281 90 |
| LUM22 HR/HRX 10 | 4081 0282 90 |
| LUM22 PR/SR 3, 4, 6, 12 | 4081 0284 90 |
| LUM22 PR/SR 10 | 4081 0285 90 |
| LUM25 HRF | 4081 0075 90 |
| LUM32 HR | 4081 0316 90 |
| LUF34 HR | 4081 0086 90 |
| TWIST HRF | 4081 0079 90 |
| TWIST VR | 4081 0078 90 |
| TWIST HR 3, 7, 12 | 4081 0291 90 |
| TWIST HR 6 | 4081 0281 90 |
| TWIST HR 10 | 4081 0292 90 |
| TWIST12 HRX 2, 3, 4 | 4081 0247 90 |
| TWIST22 HRX 2-3200, 7, 12 | 4081 0296 90 |
| TWIST22 HRX 10 | 4081 0295 90 |
| LTV009 | 4081 0248 90 |
| LTV18 | 4081 0085 90 |
| LTV19 | 4081 0288 90 |

Power you can depend on

Atlas Copco impact wrenches are designed to provide dependability and a long, trouble-free service life in the toughest conditions. Few other tools can match the Atlas Copco impact wrench when it comes to flexibility, capacity-to-weight ratio and simplicity in use and maintenance.

Atlas Copco's powerful, high-speed impact wrenches are designed to cut production times by providing rapid run-down and fast tightening. Impact wrenches build up torque in joints through a series of rotary impacts, where air pressure and tightening time affect the torque obtained. As a general rule, if a wrench impacts longer than 5 seconds on a fastener, a larger wrench should be used in order to achieve better durability.

The LMS models are non shut-off, which means they will shut off once the operator releases the trigger.

LMS

The LMS is a non shut-off impact wrench with extraordinary power to weight qualities and virtually no reaction force during tightening. The torque is applied to the joint, not to your wrist.

These tools are typically used where fast tightening or disassembly is needed and the range covers recommended torque levels between 7-5500 Nm.

LMS 8-SERIES

The new LMS 8-series impact wrenches delivers true raw power and enables extremely fast tightening and loosening.







The innovative and unique Grease Retaining System ensures maximum tool performance with long service intervals.

MINIMUM WEAR AND LOW VIBRATIONS

Each part of the durable LMS8-Series impact mechanism is produced with a very precise accuracy. This allows the maximum amount of energy to be generated in each impact. It also minimizes wear, vibration and strain on the operator.



Selection Guide

| | | | | | | | | | | | | | | | | |
|--|-------|-------|-------|-------|-------|-------|-------|-------|-------|-------|-------|-------|-------|-------|-------|-------|
|  | M6 | M8 | M10 | M12 | M14 | M16 | M18 | M20 | M22 | M24 | M27 | M30 | M36 | M42 | M45 | M48 |
| Nm | 9.8 | 24 | 47 | 81 | 128 | 197 | 275 | 385 | 518 | 665 | 961 | 1310 | 2280 | 3640 | 4510 | 5450 |
| LMS | LMS08 | LMS18 | LMS18 | LMS28 | LMS38 | LMS38 | LMS48 | LMS58 | LMS58 | LMS58 | LMS58 | LMS68 | LMS88 | LMS88 | LMS88 | LMS88 |
|  | LMS08 | LMS18 | LMS28 | LMS38 | LMS38 | LMS48 | LMS58 | LMS58 | LMS58 | LMS68 | LMS68 | LMS68 | LMS88 | | | |
|  | M6 | M8 | M10 | M12 | M14 | M16 | M18 | M20 | M22 | M24 | M27 | M30 | M36 | M42 | M45 | |
| Nm | 14 | 33 | 65 | 114 | 181 | 277 | 386 | 541 | 728 | 935 | 1350 | 1840 | 3210 | 5110 | 6340 | |
| LMS | LMS08 | LMS18 | LMS28 | LMS28 | LMS38 | LMS38 | LMS48 | LMS58 | LMS58 | LMS58 | LMS68 | LMS88 | LMS88 | LMS88 | LMS88 | |
|  | LMS18 | LMS18 | LMS28 | LMS38 | LMS48 | LMS48 | LMS58 | LMS68 | LMS68 | LMS68 | LMS88 | | | | | |
|  | M6 | M8 | M10 | M12 | M14 | M16 | M18 | M20 | M22 | M24 | M27 | M30 | M36 | M42 | | |
| Nm | 17 | 40 | 79 | 136 | 217 | 333 | 463 | 649 | 874 | 1120 | 1620 | 2210 | 3850 | 6140 | | |
| LMS | LMS08 | LMS18 | LMS28 | LMS28 | LMS38 | LMS48 | LMS58 | LMS58 | LMS58 | LMS68 | LMS88 | LMS88 | LMS88 | LMS88 | | |
|  | LMS18 | LMS18 | LMS28 | LMS38 | LMS48 | LMS58 | LMS68 | LMS68 | LMS68 | LMS88 | | | | | | |

■ = **HEAVY DUTY**

■ = **EXTRA HEAVY DUTY**

The torque figures are normal tightening torque for untreated oil-smearred and rust-protected bolts and nuts in the most common strength grades. The torque figures correspond to approximately 63% of tensile stress.

LMS MODELS

- Recommended operating range 7-1800 Nm.
- Fast tightening and disassembly.
- Negligible reaction force.
- Low weight.
- High power-to-weight ratio.
- Tightening time should not exceed 5 seconds, to avoid excess wear on the tool.
- Soft-start throttle.
- Long service intervals.
- Durable high performance with Grease Retaining System.



LMS18 HR13



LMS58 HR25

| Model | Bolt size mm | Square drive in | Torque range | | Max torque | | Impacts per min | Free speed r/min | Weight | | Length excl. anvil mm | CS distance mm | Air consumption under load | | Rec. hose size mm | Air inlet thread in | Ordering No. |
|--------------|--------------|--------------------|--------------|----------|------------|-------|-----------------|------------------|--------|------|-----------------------|----------------|----------------------------|------|-------------------|---------------------|--------------|
| | | | Nm | ft lb | Nm | ft lb | | | kg | lb | | | l/s | cfm | | | |
| LMS08 HR10 | 6-8 | 3/8 ^c | 7-45 | 5-33 | 65 | 48 | 1650 | 14000 | 0.9 | 2.0 | 185 | 21 | 2.5 | 5 | 6.3 | 1/4 | 8434 1080 00 |
| LMS08 HR42 | 6-8 | 1/4 ^a | 7-35 | 5-26 | 60 | 44 | 1650 | 14000 | 0.9 | 2.0 | 186 | 21 | 2.5 | 5 | 6.3 | 1/4 | 8434 1080 05 |
| LMS18 HR13 | 10 | 1/2 ^c | 10-110 | 7-81 | 150 | 110 | 1500 | 8100 | 1.45 | 3.2 | 144 | 26 | 8.5 | 18 | 10 | 1/4 | 8434 1180 00 |
| LMS18 HR10 | 10 | 3/8 ^c | 10-90 | 7-66 | 120 | 88 | 1650 | 8100 | 1.45 | 3.2 | 148 | 26 | 6.5 | 14 | 10 | 1/4 | 8434 1180 01 |
| LMS18 HR13/F | 10 | 1/2 ^e | 10-110 | 7-81 | 150 | 110 | 1500 | 8100 | 1.45 | 3.2 | 144 | 26 | 8.5 | 18 | 10 | 1/4 | 8434 1180 02 |
| LMS18 HR10/F | 10 | 3/8 ^e | 10-90 | 7-66 | 120 | 88 | 1650 | 8100 | 1.45 | 3.2 | 148 | 26 | 6.5 | 14 | 10 | 1/4 | 8434 1180 03 |
| LMS28 HR13 | 12 | 1/2 ^c | 30-210 | 22-155 | 390 | 287 | 1500 | 9500 | 1.85 | 4.1 | 146 | 29 | 8.5 | 18 | 10 | 3/8 | 8434 1280 00 |
| LMS28 HR13/F | 12 | 1/2 ^e | 30-210 | 22-155 | 390 | 287 | 1500 | 9500 | 1.85 | 4.1 | 146 | 29 | 8.5 | 18 | 10 | 3/8 | 8434 1280 01 |
| LMS38 HR13 | 14-16 | 1/2 ^c | 40-375 | 29-276 | 850 | 627 | 1350 | 8000 | 2.6 | 5.7 | 167 | 29 | 10 | 21 | 10 | 3/8 | 8434 1380 00 |
| LMS38 HR13/F | 14-16 | 1/2 ^e | 40-375 | 29-276 | 850 | 627 | 1350 | 8000 | 2.6 | 5.7 | 167 | 29 | 10 | 21 | 10 | 3/8 | 8434 1380 01 |
| LMS48 HR20 | 16-18 | 3/4 ^d | 100-550 | 74-405 | 1375 | 1014 | 1100 | 6500 | 3.3 | 7.3 | 173 | 38 | 12 | 25.2 | 12.5 | 3/8 | 8434 1480 00 |
| LMS58 HR25 | 20-22 | 1 ^d | 300-800 | 221-590 | 1900 | 1401 | 900 | 5500 | 4.8 | 10.6 | 210 | 42 | 14.5 | 30.5 | 12.5 | 3/8 | 8434 1580 00 |
| LMS58 HR20 | 18-20 | 3/4 ^d | 300-800 | 221-590 | 1900 | 1401 | 900 | 5500 | 4.8 | 10.6 | 210 | 42 | 14.5 | 30.5 | 12.5 | 3/8 | 8434 1580 01 |
| LMS68 HR25 | 22-30 | 1 ^d | 600-1800 | 442-1400 | 4450 | 3282 | 780 | 5000 | 9.8 | 21.5 | 252 | 55 | 28 | 58.9 | 16 | 1/2 | 8434 1680 01 |
| LMS68 HR S5 | 22-30 | 1 5/8 ^b | 600-1800 | 442-1400 | 4450 | 3282 | 780 | 5000 | 9.8 | 21.5 | 252 | 55 | 28 | 58.9 | 16 | 1/2 | 8434 1680 03 |

^a Female hex. quick change chuck.

^b Spline drive No. 5.

^c Pin retainer

^d Through hole

^e Friction ring

LMS MODELS

- Recommended operating range 7-5500 Nm.
- Fast tightening and disassembly.
- Negligible reaction force.
- Low weight.
- High power-to-weight ratio.
- Soft-start throttle.
- Tightening time should not exceed 5 seconds, to avoid excess wear on the tool.
- Long service intervals.
- Durable high performance with grease retaining system.



LMS68 GIR25



LMS08 SR10



LMS88 GIR38

| Model | Bolt size mm | Square drive in | Torque range | | Max torque | | Impacts per min | Free speed r/min | Weight | | Length excl. anvil mm | CS distance mm | Air consumption under load | | Rec. hose size mm | Air inlet thread in | Ordering No. |
|--------------|--------------|--------------------|--------------|----------|------------|-------|-----------------|------------------|--------|------|-----------------------|----------------|----------------------------|------|-------------------|---------------------|--------------|
| | | | Nm | ft lb | Nm | ft lb | | | kg | lb | | | l/s | cfm | | | |
| LMS08 SR42 | 6-8 | 1/4 ^a | 7-35 | 5-26 | 60 | 44 | 1650 | 12500 | 0.85 | 1.9 | 185 | 20 | 5.5 | 9.1 | 6.3 | 1/4 | 8434 1081 06 |
| LMS08 SR10 | 6-8 | 3/8 ^c | 7-45 | 5-33 | 65 | 48 | 1650 | 12500 | 0.85 | 1.9 | 184 | 20 | 5.5 | 9.1 | 6.3 | 1/4 | 8434 1081 11 |
| LMS68 GIR25 | 22-30 | 1 ^d | 600-1800 | 442-1400 | 4450 | 3282 | 780 | 5000 | 9.6 | 21.1 | 339 | 55 | 28 | 58.9 | 16 | 1/2 | 8434 1680 00 |
| LMS68 GOR25 | 22-30 | 1 ^d | 600-1800 | 442-1400 | 4450 | 3282 | 780 | 5000 | 9.6 | 21.1 | 339 | 55 | 28 | 58.9 | 16 | 1/2 | 8434 1680 02 |
| LMS68 GIR S5 | 22-30 | 1 5/8 ^b | 600-1800 | 442-1400 | 4450 | 3282 | 780 | 5000 | 9.6 | 21.1 | 339 | 55 | 28 | 58.9 | 16 | 1/2 | 8434 1680 05 |
| LMS68 GOR S5 | 22-30 | 1 5/8 ^b | 600-1800 | 442-1400 | 4450 | 3282 | 780 | 5000 | 9.6 | 21.1 | 339 | 55 | 28 | 58.9 | 16 | 1/2 | 8434 1680 10 |
| LMS88 GIR38 | 30-42 | 1 1/2 ^d | 1000-5500 | 737-4054 | 10000 | 7370 | 540 | 3800 | 15.0 | 33.0 | 381 | 63.5 | 33 | 69.4 | 16 | 1/2 | 8434 1880 00 |
| LMS88 GOR38 | 30-42 | 1 1/2 ^d | 1000-5500 | 737-4054 | 10000 | 7370 | 540 | 3800 | 15.0 | 33.0 | 381 | 63.5 | 33 | 69.4 | 16 | 1/2 | 8434 1880 01 |
| LMS88 GIR S5 | 30-42 | 1 5/8 ^b | 1000-5500 | 737-4054 | 10000 | 7370 | 540 | 3800 | 15.0 | 33.0 | 381 | 63.5 | 33 | 69.4 | 16 | 1/2 | 8434 1880 05 |
| LMS88 GOR S5 | 30-42 | 1 5/8 ^b | 1000-5500 | 737-4054 | 10000 | 7370 | 540 | 3800 | 15.0 | 33.0 | 381 | 63.5 | 33 | 69.4 | 16 | 1/2 | 8434 1880 10 |

^a Female hex. quick change chuck.

^b Spline drive No. 5.

^c Pin retainer

^d Through hole

GOR = Outside trigger.

GIR = Inside trigger.

Optional Accessories

MULTIFLEX SWIVEL

| Model | Ordering No. |
|---|--------------|
| LMS08 HR10/SR10, LMS18 HR10/13 | 8202 1350 20 |
| LMS18 HR10/13, LMS28/38 HR13, LMS48/58 HR20, LMS58 HR25 | 8202 1350 22 |
| LMS68 HR25, LMS68/88 GIR, LMS68/88 GOR | 8202 1350 24 |



MultiFlex Swivel

WHIP HOSE

| Model | Hose nipple | Ordering No. |
|--|------------------|--------------|
| LMS08 HR10/SR10, LMS18 HR10/13 | ErgoNIP 10, 1/4" | 8202 1180 42 |
| LMS28/38 HR13, LMS48/58 HR20, LMS58 HR25 | ErgoNIP 10, 3/8" | 8202 1180 44 |
| LMS68 HR25, LMS68/88 GIR, LMS68/88 GOR | ErgoNIP 10, 5/8" | 8202 1180 28 |



Whip hose

SUSPENSION YOKE

| Model | Ordering No. |
|---|--------------|
| LMS68 GIR25/GOR25/GIRS5/GORS5/HRS5/HR25 | 4250 0677 81 |
| LMS88 GIR38/GOR38/GIRS5/GORS5 | 0371 1102 00 |

Suspension yoke included LMS08-58

Productivity Kits

| Model | Max air flow | Hose 16.4 ft | Coupling | Lubrication | Ordering No. |
|--|--------------|--------------|--------------|-------------|--------------|
| For small impact wrenches and pulse tools | | | | | |
| MIDI Optimizer F/RD EP EQ08US-C08 | 19 cfm | Cablair 08 | ErgoQIC 08US | Yes | 8202 0850 45 |
| For 1/2" impact wrenches and pulse tools | | | | | |
| MIDI Optimizer F/RD EP EQ10US-C10 | 34 cfm | Cablair 10 | ErgoQIC 10US | Yes | 8202 0850 46 |
| For impact wrenches and pulse tools | | | | | |
| MIDI Optimizer F/RD EP EQ10US-C13 | 50 cfm | Cablair 13 | ErgoQIC 10US | Yes | 8202 0850 47 |
| MIDI Optimizer F/RD EP EQ10US-T13 | 65 cfm | Turbo 13 | ErgoQIC 10US | Yes | 8202 0850 48 |

NOTE: Tool nipple is not included in the Productivity kit and needs to be order separately together with the tool.



Service Kits

The spare parts included in the service kits cover a normal overhaul of your tool. Always have them available for a fast and economical repair.

Main parts included:

- Gaskets
- O-rings
- Circlips
- Pins etc.

| Model | Service kit |
|-------|--------------|
| LMS08 | 4081 0465 90 |
| LMS18 | 4081 0466 90 |
| LMS28 | 4081 0467 90 |
| LMS38 | 4081 0468 90 |
| LMS48 | 4081 0461 90 |
| LMS58 | 4081 0445 90 |
| LMS68 | 4081 0442 90 |
| LMS88 | 4081 0443 90 |

ErgoPulse impulse tools – fast, reliable and operator friendly

The speed, reliability, and accuracy of ErgoPulse hydraulic impulse nutrunners, combined with the fact that they are comfortable to operate, make them suitable for continuous heavy production. Since there is no metal-to-metal impact in a pulse tool, it provides a softer, more controlled pulse with considerably less vibration and noise than an impact wrench.

A COMPLETE RANGE

ErgoPulse impulse tools are available in straight and pistol grip, shut-off and non shut-off versions. The range covers torque from 2–900 Nm.

The ErgoPulse principle – The heart of a pulse tool is the hydraulic pulse unit. Since the pulses are very short, there is almost no reaction force in the handle, only the much lower motor torque is transferred to the operator's hand. In addition, there are less vibrations and noise than with an impact wrench. Combined with good balance and low weight the result is a tool that is very comfortable to operate.

PTS AND PTX SHUT-OFF PULSE TOOLS

Atlas Copco shut-off pulse tools shut off the air supply when the pre-set torque is reached. Operator influence is minimized and the result is increased accuracy and faster tightening.

Torque sensing system – In ErgoPulse PTS and PTX nutrunners torque is "sensed" by means of a rotatable inertial mass acting against an adjustable spring. The result is a highly accurate and easily adjustable shut-off system.

Pulse mechanism – The pulse mechanism has pistons for minimum weight and long service life. The design is based on cam-guided pistons and rollers and the pulse cylinder is oil-filled. The moving parts are thus completely immersed in oil, which ensures a long service life.

Twin chamber vane motor – This is designed to give high torque at low speed, which gives the best characteristics for fast, accurate tightening.

TRIM valve – A patented adjustable valve at the air outlet is used to maximize tool accuracy on one type of joint, which could be hard, medium or soft.

AUTOTRIM valve – PTS/PTX-AT tools are equipped with an automatic two-stage trim valve. The tool runs down the screw with reduced free speed. After 1-2 pulses it shifts automatically to full power thus enabling both hard and soft joints to

be tightened with excellent results without any adjustments. The PTS/PTX tools can also be used for reporting applications. ErgoPulse PTS-HRF – These are Air-on-Top versions which offer full flexibility. You either use the air inlet on top to avoid the disturbing hose hook or you use the conventional air inlet at the bottom of the handle – a convenient tool for use in workstations.

ErgoPulse PTX – The new ErgoPulse PTX series is intended for applications where weight is critical. The tools are available in both Trim and AutoTrim versions.

ERGOPULSE 25PTX

At the top of the PTX range, is the new ErgoPulse 25PTX, which gives you 900 Nm of tightening torque in a tool weighing only 10,3 kg (22.7 lbs).

ERGOPULSE XS NON SHUT-OFF TOOLS

ErgoPulse XS is the correct choice when the operator needs to control the process. The tools provide high torque, fast, accurate tightening and long service lifetimes.

Twin chamber vane motor – This is designed to give high torque at low speed, which provides the best characteristics for fast, reliable and accurate tightening.

Double or triple bladed pulse mechanisms – The tools are equipped with pulse units with two or three blades. They employ the Atlas Copco patented cam-guided design to push out the blades, giving very high reliability. The pulse units have a high power-to-weight ratio, making the tools very powerful for their size. Torque is adjusted by regulating an artificial leak in the hydraulic circuit.

ERGOPULSE 6PS

This model is a good choice for tightening self-tapping screws and when fast, powerful reversing is needed. Torque is adjusted by regulating the air pressure.



EP PTS/PTX SHUT-OFF MODELS

The ErgoPulse PTS and PTX tools can be adjusted within a wide torque range by simply setting the spring force that counteracts the inertia body. Torque should preferably be checked with a hand torque wrench. Electronic monitoring with an in-line transducer is possible but should be verified with a manual hand torque wrench to avoid measuring errors due to the extremely short pulse sequence.

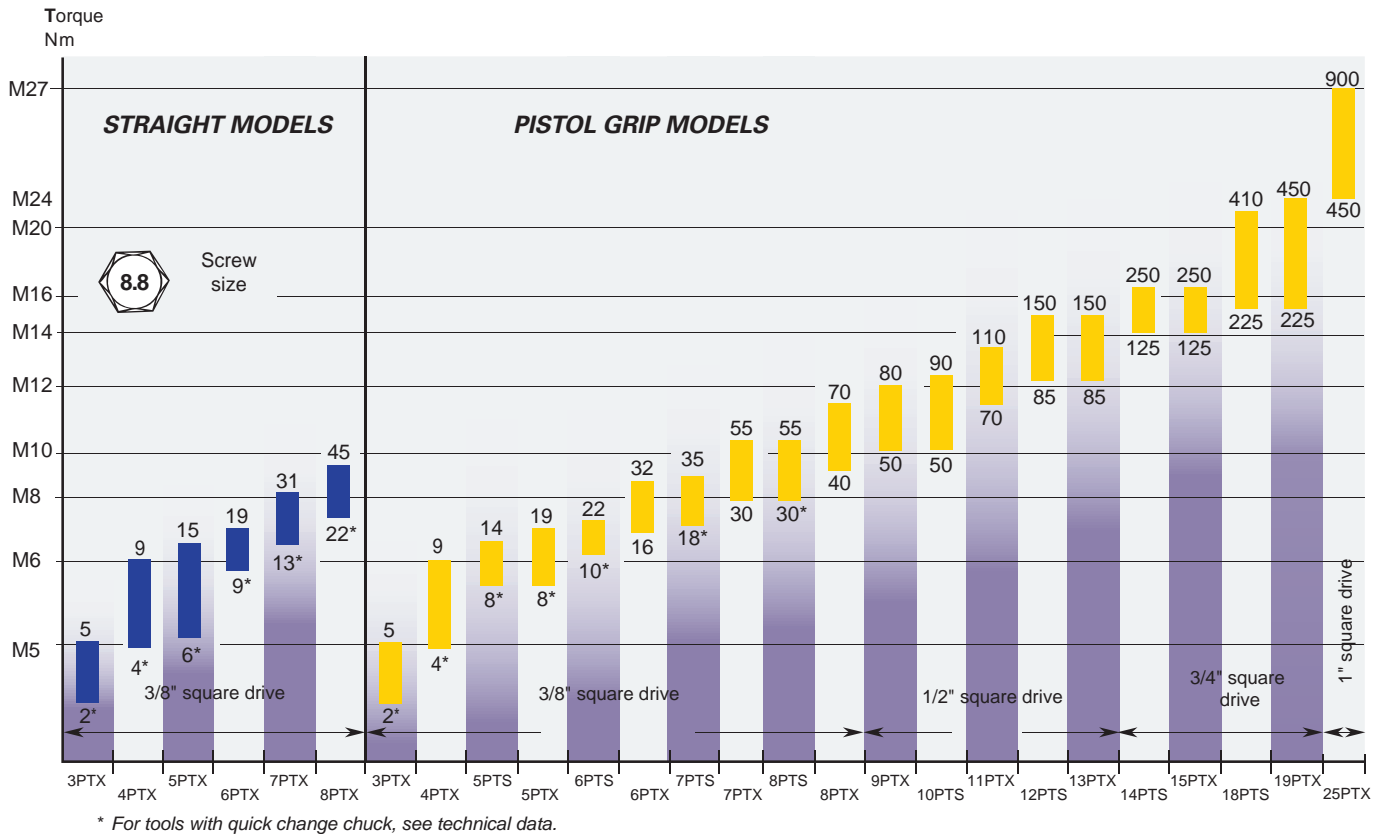

EP XS/PS NON SHUT-OFF MODELS

The size of tool is determined on the basis of torque and/or bolt dimension. Torque should preferably be checked with a hand torque wrench. Electronic monitoring with an in-line transducer is possible but should be verified with a manual hand torque wrench to avoid measuring errors due to the extremely short pulse sequence.

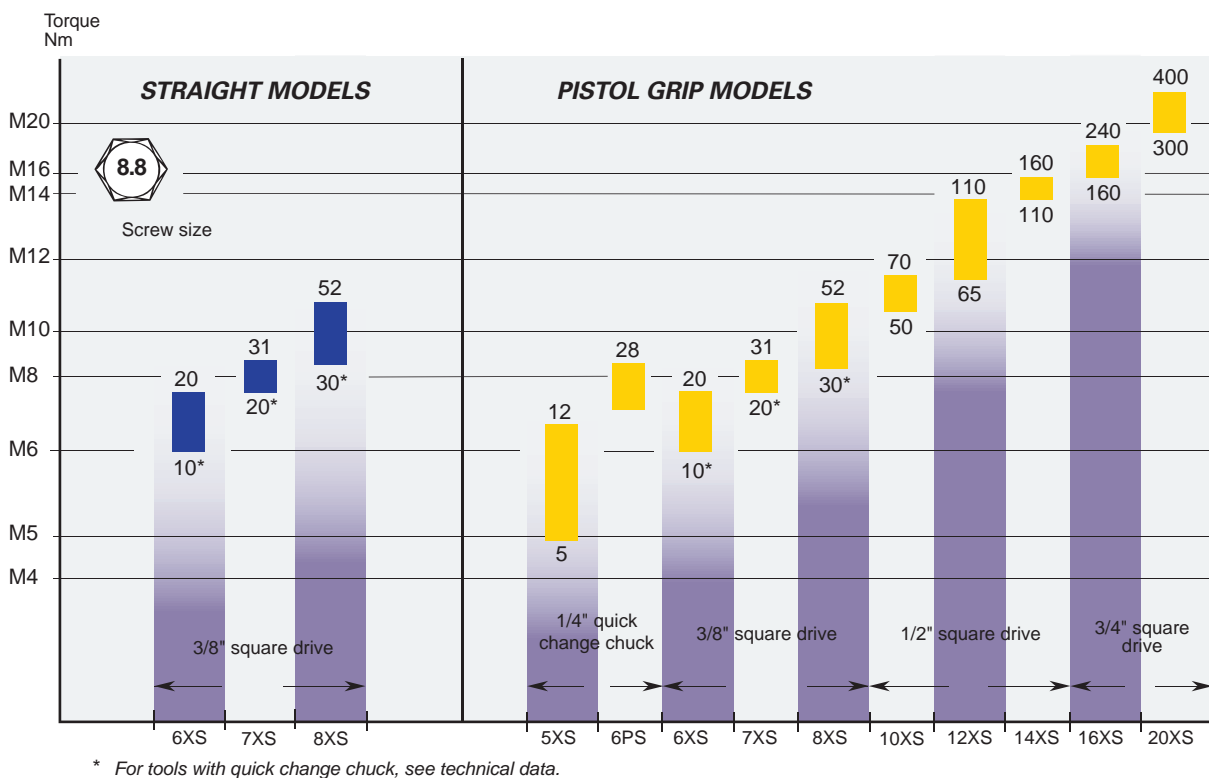

EP PTX MODELS

In ErgoPulse shut-off tools the air supply is shut off as soon as the pre-set torque has been reached, minimizing operator influence. The result is increased accuracy and faster tightening.

- High reliability.
- Consistent torque over time, low mean-shift.
- High level of durability.
- High speed, short cycle times.
- One-handed operation.
- High power-to-weight ratio.
- No springs to wear out.
- No wear on key parts.
- High precision components.
- No reaction forces.
- Light, well-balanced tools.
- Low noise levels.
- Lubrication free.



| Model | Bolt size mm | Square drive in | Torque range ^a | | Free speed r/min | Weight | | Length mm | CS distance mm | Air consumption under load | | Rec. hose size mm | Air inlet thread in | Ordering No. |
|-------------------------------------|-----------------|--------------------|---------------------------|---------|---------------------|--------|-----|--------------|-------------------|----------------------------|-----|----------------------|------------------------|--------------|
| | | | Nm | ft lb | | kg | lb | | | l/s | cfm | | | |
| TRIM-RE | | | | | | | | | | | | | | |
| EP3PTX5 HR42-RE | M4-M5 | 1/4 ^b | 2-5 | 1.6-4 | 5000 ^c | 0.8 | 1.7 | 154 | 21 | 4 | 9 | 8 | 1/4 | 8431 0375 51 |
| EP4PTX9 HR10-RE | M5 | 3/8 | 4-9 | 3-7 | 3400 ^c | 0.9 | 1.9 | 164 | 22 | 4 | 9 | 8 | 1/4 | 8431 0375 54 |
| EP4PTX9 HR42-RE | M5 | 1/4 ^b | 4-9 | 3-7 | 3400 ^c | 0.9 | 1.9 | 164 | 22 | 4 | 9 | 8 | 1/4 | 8431 0375 50 |
| EP5PTX17 HR42-RE | M6 | 1/4 ^b | 7-17 | 5-13 | 7000 ^c | 0.9 | 1.9 | 164 | 22 | 7 | 15 | 8 | 1/4 | 8431 0375 00 |
| EP5PTX19 HR10-RE | M6 | 3/8 | 8-19 | 6-14 | 7000 ^c | 0.9 | 1.9 | 164 | 22 | 7 | 15 | 8 | 1/4 | 8431 0375 04 |
| EP6PTX28 HR42-RE | M6-M8 | 1/4 ^b | 15-28 | 11-18 | 8500 ^c | 0.9 | 1.9 | 164 | 22 | 7 | 15 | 8 | 1/4 | 8431 0375 10 |
| EP6PTX32 HR10-RE | M6-M8 | 3/8 | 16-32 | 12-23 | 8500 ^c | 0.9 | 1.9 | 164 | 22 | 7 | 15 | 8 | 1/4 | 8431 0375 20 |
| EP7PTX55 HR10-RE | M8-M10 | 3/8 | 30-55 | 22-40 | 7200 ^c | 1.2 | 2.5 | 176 | 25 | 9 | 19 | 10 | 1/4 | 8431 0375 30 |
| EP8PTX70 HR10-RE | M10 | 3/8 | 40-70 | 29-51 | 6900 ^c | 1.2 | 2.5 | 176 | 25 | 9 | 19 | 10 | 1/4 | 8431 0375 60 |
| EP9PTX80 HR13-RE | M10 | 1/2 | 50-80 | 37-59 | 5200 ^c | 1.5 | 3.3 | 188 | 29 | 11 | 23 | 10 | 1/4 | 8431 0375 40 |
| EP11PTX110 HR13-RE | M12 | 1/2 | 70-110 | 51-81 | 5100 ^c | 1.7 | 3.8 | 196 | 29 | 12 | 25 | 10 | 1/4 | 8431 0375 50 |
| EP13PTX150 HR13-RE | M12-M14 | 1/2 | 85-150 | 63-110 | 5300 ^c | 2.3 | 5.1 | 197 | 33.5 | 15 | 32 | 13 | 3/8 | 8431 0376 60 |
| EP15PTX250 HR20-RE | M12-M16 | 3/4 | 125-250 | 92-184 | 4300 ^c | 3.1 | 6.8 | 216 | 36.5 | 21 | 45 | 13 | 3/8 | 8431 0376 70 |
| EP19PTX450 HR20-RE | M16-M20 | 3/4 | 225-450 | 166-332 | 3300 ^c | 4.2 | 9.2 | 221 | 44 | 23 | 49 | 13 | 3/8 | 8431 0376 80 |
| Trim-RE Low pressure models | | | | | | | | | | | | | | |
| EP5PTX HR10-RE-L | M5 | 3/8 | 7-15 | 5-11 | 5900 ^d | 0.9 | 2.0 | 164 | 22 | 4 | 9 | 8 | 1/4 | 8431 0379 04 |
| EP5PTX HR42-RE-L | M4-M5 | 1/4 ^b | 6-13 | 4-10 | 5900 ^d | 0.8 | 1.8 | 154 | 21 | 4 | 9 | 8 | 1/4 | 8431 0379 00 |
| EP6PTX HR10-RE-L | M6 | 3/8 | 13-25 | 9-18 | 7900 ^d | 0.9 | 2.0 | 164 | 22 | 7 | 15 | 8 | 1/4 | 8431 0379 20 |
| EP6PTX HR42-RE-L | M5 | 1/4 ^b | 11-22 | 8-16 | 7900 ^d | 0.9 | 2.0 | 164 | 22 | 4 | 9 | 8 | 1/4 | 8431 0379 10 |
| EP7PTX HR10-RE-L | M6 | 3/8 | 23-35 | 17-26 | 6200 ^d | 0.9 | 2.0 | 164 | 22 | 7 | 15 | 10 | 1/4 | 8431 0379 30 |
| EP8PTX HR10-RE-L | M6-M8 | 3/8 | 33-45 | 24-33 | 6300 ^d | 0.9 | 2.0 | 164 | 22 | 7 | 15 | 10 | 1/4 | 8431 0379 60 |
| AutoTrim | | | | | | | | | | | | | | |
| EP3PTX5 HR42-AT | M4-M5 | 1/4 ^b | 2-5 | 1.6-4 | 4500 ^c | 0.8 | 1.8 | 154 | 21 | 4 | 9 | 8 | 1/4 | 8431 0375 53 |
| EP4PTX9 HR10-AT | M5 | 3/8 | 4-9 | 3-7 | 3300 ^c | 0.9 | 2.0 | 164 | 22 | 4 | 9 | 8 | 1/4 | 8431 0375 56 |
| EP4PTX9 HR42-AT | M5 | 1/4 ^b | 4-9 | 3-7 | 3300 ^c | 0.9 | 2.0 | 164 | 22 | 4 | 9 | 8 | 1/4 | 8431 0375 52 |
| EP5PTX17 HR42-AT | M6 | 1/4 ^b | 7-17 | 5-13 | 5400 ^c | 0.9 | 2.0 | 164 | 22 | 7 | 15 | 8 | 1/4 | 8431 0375 02 |
| EP5PTX19 HR10-AT | M6 | 3/8 | 8-19 | 6-14 | 5400 ^c | 0.9 | 2.0 | 164 | 22 | 7 | 15 | 8 | 1/4 | 8431 0375 06 |
| EP6PTX28 HR42-AT | M6-M8 | 1/4 ^b | 15-28 | 11-18 | 8500 ^c | 0.9 | 2.0 | 164 | 22 | 7 | 15 | 8 | 1/4 | 8431 0375 12 |
| EP6PTX32 HR10-AT | M6-M8 | 3/8 | 16-32 | 12-23 | 8500 ^c | 0.9 | 2.0 | 164 | 22 | 7 | 15 | 8 | 1/4 | 8431 0375 22 |
| EP7PTX55 HR10-AT | M8-M10 | 3/8 | 30-55 | 22-40 | 6900 ^c | 1.2 | 2.5 | 176 | 25 | 9 | 19 | 10 | 1/4 | 8431 0375 32 |
| EP8PTX70 HR10-AT | M10 | 3/8 | 40-70 | 29-51 | 6900 ^c | 1.2 | 2.5 | 176 | 25 | 9 | 19 | 10 | 1/4 | 8431 0375 62 |
| EP9PTX80 HR13-AT | M10 | 1/2 | 50-80 | 37-59 | 5100 ^c | 1.5 | 3.4 | 188 | 29 | 11 | 23 | 10 | 1/4 | 8431 0375 42 |
| EP11PTX110 HR13-AT | M12 | 1/2 | 70-110 | 51-81 | 5100 ^c | 1.7 | 3.8 | 196 | 29 | 12 | 25 | 10 | 1/4 | 8431 0376 52 |
| EP13PTX150 HR13-AT | M12-M14 | 1/2 | 85-150 | 63-110 | 5300 ^c | 2.3 | 5.0 | 197 | 33.5 | 15 | 32 | 13 | 3/8 | 8431 0376 62 |
| EP15PTX250 HR20-AT | M12-M16 | 3/4 | 125-250 | 92-184 | 4200 ^c | 3.1 | 6.8 | 216 | 36.5 | 21 | 45 | 13 | 3/8 | 8431 0376 72 |
| EP19PTX450 HR20-AT | M16-M20 | 3/4 | 225-450 | 166-332 | 3300 ^c | 4.2 | 9.2 | 221 | 44 | 23 | 49 | 13 | 3/8 | 8431 0376 82 |
| AutoTrim Low pressure models | | | | | | | | | | | | | | |
| EP5PTX HR10-AT-L | M5 | 3/8 | 7-15 | 5-11 | 5900 ^d | 0.9 | 2.0 | 164 | 22 | 4 | 9 | 8 | 1/4 | 8431 0379 06 |
| EP5PTX HR42-AT-L | M4-M5 | 1/4 ^b | 6-13 | 4-10 | 5900 ^d | 0.8 | 1.8 | 154 | 21 | 4 | 9 | 8 | 1/4 | 8431 0379 02 |
| EP6PTX HR10-AT-L | M6 | 3/8 | 13-25 | 9-18 | 7900 ^d | 0.9 | 2.0 | 164 | 22 | 7 | 15 | 8 | 1/4 | 8431 0379 22 |
| EP6PTX HR42-AT-L | M5 | 1/4 ^b | 11-22 | 8-16 | 7900 ^d | 0.9 | 2.0 | 164 | 22 | 4 | 9 | 8 | 1/4 | 8431 0379 12 |
| EP7PTX HR10-AT-L | M6 | 3/8 | 23-35 | 17-26 | 6200 ^d | 0.9 | 2.0 | 164 | 22 | 7 | 15 | 10 | 1/4 | 8431 0379 32 |
| EP8PTX HR10-AT-L | M6-M8 | 3/8 | 33-45 | 24-33 | 6300 ^d | 0.9 | 2.0 | 164 | 22 | 7 | 15 | 10 | 1/4 | 8431 0379 62 |

^a To be used as a guide only, final torque depends on type of joint, accessories used and air pressure. ^b Female hexagon drive. Quick change chuck. ^c In full speed mode. ^d Measured at 5 bar air pressure.

EP PTS MODELS

ErgoPulse PTS is the reliable and powerful workhorse and offers the same shut-off mechanism as the peak performer PTX. The PTS series has some air on top HRF models, making it possible to feed the air from above to the tool to make it easier to use in many applications. All PTS models can also be used as lubrication free, just like other ErgoPulse tools.



| Model | Bolt size mm | Square drive in | Torque range ^a | | Free speed r/min | Weight | | Length mm | CS distance mm | Air consumption under load | | Rec. hose size mm | Air inlet thread in | Ordering No. |
|------------------------------------|-----------------|--------------------|---------------------------|---------|---------------------|--------|-----|--------------|-------------------|----------------------------|-----|----------------------|------------------------|--------------|
| | | | Nm | ft lb | | kg | lb | | | l/s | cfm | | | |
| TRIM-RE | | | | | | | | | | | | | | |
| EP5PTS12 HR42-RE | M5-M6 | 1/4 ^b | 6-12 | 4-9 | 5400 ^c | 1.0 | 2.2 | 196 | 21 | 6.5 | 14 | 8 | 1/4 | 8431 0374 05 |
| EP5PTS14 HR10-RE | M5-M6 | 3/8 | 8-14 | 6-10 | 5400 ^c | 1.0 | 2.2 | 191 | 21 | 6.5 | 14 | 8 | 1/4 | 8431 0374 00 |
| EP6PTS22 HR10-RE | M6 | 3/8 | 10-22 | 7-16 | 7300 ^c | 1.0 | 2.2 | 191 | 21 | 7 | 15 | 8 | 1/4 | 8431 0374 20 |
| EP6PTS20 HR42-RE | M6 | 1/4 ^b | 8-20 | 6-15 | 7300 ^c | 1.0 | 2.2 | 196 | 21 | 7 | 15 | 8 | 1/4 | 8431 0374 15 |
| TRIM-RE with balanced grip | | | | | | | | | | | | | | |
| EP7PTS30 HR42-RE | M8 | 1/4 ^b | 16-31 | 12-23 | 5700 ^c | 1.4 | 3.0 | 175 | 26 | 8 | 17 | 10 | 1/4 | 8431 0374 35 |
| EP7PTS35 HR10-RE | M8 | 3/8 | 18-35 | 13-26 | 5700 ^c | 1.4 | 3.0 | 176 | 26 | 8 | 17 | 10 | 1/4 | 8431 0374 40 |
| EP8PTS40 HR42-RE | M8 | 1/4 ^b | 22-40 | 16-29 | 7300 ^c | 1.4 | 3.0 | 175 | 26 | 9 | 19 | 10 | 1/4 | 8431 0374 55 |
| EP8PTS55 HR10-RE | M8-M10 | 3/8 | 30-55 | 22-40 | 7300 ^c | 1.4 | 3.0 | 176 | 26 | 9 | 19 | 10 | 1/4 | 8431 0374 60 |
| EP10PTS90 HR13-RE | M10-M12 | 1/2 | 50-90 | 37-66 | 5200 ^c | 1.8 | 4.0 | 193 | 29 | 11 | 23 | 10 | 1/4 | 8431 0374 80 |
| EP12PTS150 HR13-RE | M12-M14 | 1/2 | 85-150 | 63-110 | 4200 ^c | 2.5 | 5.5 | 201 | 34 | 13 | 27 | 13 | 3/8 | 8431 0374 90 |
| EP14PTS250 HR20-RE | M12-M16 | 3/4 | 125-250 | 92-185 | 4000 ^c | 3.3 | 7.2 | 216 | 37 | 20 | 42 | 13 | 3/8 | 8431 0374 95 |
| EP18PTS410 HR20-RE | M16-M20 | 3/4 | 225-410 | 166-302 | 3000 ^c | 4.3 | 9.5 | 202 | 42 | 22 | 46 | 13 | 3/8 | 8431 0374 98 |
| TRIM-RE with Air on top | | | | | | | | | | | | | | |
| EP7PTS35 HRF10-RE | M8 | 3/8 | 18-35 | 13-26 | 5700 ^c | 1.4 | 3.0 | 176 | 31 | 8 | 17 | 10 | 1/4 | 8431 0374 41 |
| EP8PTS55 HRF10-RE | M8-M10 | 3/8 | 30-55 | 22-40 | 7300 ^c | 1.4 | 3.0 | 176 | 31 | 9 | 19 | 10 | 1/4 | 8431 0374 61 |
| EP10PTS90 HRF13-RE | M10-M12 | 1/2 | 50-90 | 37-66 | 5200 ^c | 1.8 | 4.0 | 193 | 34 | 11 | 23 | 10 | 1/4 | 8431 0374 81 |
| AutoTrim | | | | | | | | | | | | | | |
| EP6PTS20 HR42-AT | M6 | 1/4 ^b | 8-20 | 6-15 | 6300 ^d | 1.0 | 2.2 | 196 | 21 | 7 | 15 | 8 | 1/4 | 8431 0374 16 |
| EP6PTS22 HR10-AT | M6 | 3/8 | 10-22 | 7-16 | 6300 ^d | 1.0 | 2.2 | 191 | 21 | 7 | 15 | 8 | 1/4 | 8431 0374 21 |
| AutoTrim with balanced grip | | | | | | | | | | | | | | |
| EP7PTS30 HR42-AT | M8 | 1/4 ^b | 16-31 | 12-23 | 5400 ^d | 1.4 | 3.0 | 175 | 26 | 8 | 17 | 10 | 1/4 | 8431 0374 37 |
| EP7PTS35 HR10-AT | M8 | 3/8 | 18-35 | 13-26 | 5400 ^d | 1.4 | 3.0 | 176 | 26 | 8 | 17 | 10 | 1/4 | 8431 0374 42 |
| EP8PTS40 HR42-AT | M8 | 1/4 ^b | 22-40 | 16-29 | 6900 ^d | 1.4 | 3.0 | 175 | 26 | 9 | 19 | 10 | 1/4 | 8431 0374 57 |
| EP8PTS55 HR10-AT | M8-10 | 3/8 | 30-55 | 22-40 | 6900 ^d | 1.4 | 3.0 | 176 | 26 | 9 | 19 | 10 | 1/4 | 8431 0374 62 |
| EP10PTS90 HR13-AT | M10-12 | 1/2 | 50-90 | 37-66 | 4900 ^d | 1.8 | 4.0 | 193 | 29 | 11 | 23 | 10 | 1/4 | 8431 0374 82 |
| EP12PTS150 HR13-AT | M12-14 | 1/2 | 85-150 | 63-110 | 4100 ^d | 2.5 | 5.5 | 201 | 34 | 13 | 27 | 13 | 3/8 | 8431 0374 92 |
| EP14PTS250 HR20-AT | M12-16 | 3/4 | 125-250 | 92-185 | 3900 ^d | 3.3 | 7.2 | 216 | 37 | 20 | 42 | 13 | 3/8 | 8431 0374 97 |
| EP18PTS410 HR20-AT | M16-20 | 3/4 | 225-410 | 166-332 | 2900 ^d | 4.3 | 9.5 | 202 | 42 | 22 | 46 | 13 | 3/8 | 8431 0374 99 |

^a To be used as a guide only, final torque depends on type of joint, accessories used and air pressure.

^b Female hexagon drive. Quick change chuck.
^c With TRIM valve fully open.

^d In full speed mode.

EP XS MODELS

In ErgoPulse non shut-off tools the tool produces pulses until the operator releases the trigger. Preferred in applications where it is an advantage for the operator to be able to control the process by shutting off the tool manually.

- High reliability and durability.
- High speed, short cycle times.
- One-handed operation.
- High power-to-weight ratio.
- No springs to wear out.
- High precision components.
- No reaction forces.
- Light, well-balanced tools.
- Low noise levels.
- Lubrication free.



| Model | Bolt size mm | Square drive in | Torque range ^a | | Free speed r/min | Weight | | Length mm | CS distance mm | Air consumption under load | | Rec. hose size mm | Air inlet thread in | Ordering No. |
|-------------|-----------------|--------------------|---------------------------|---------|---------------------|--------|------|--------------|-------------------|----------------------------|-----|----------------------|------------------------|--------------|
| | | | Nm | ft lb | | kg | lb | | | l/s | cfm | | | |
| EP6PS HR10 | M8 | 3/8 | ~30 | ~22 | 8000 | 0.8 | 1.8 | 150 | 21 | 9 | 19 | 10 | 1/4 | 8431 0368 21 |
| EP6PS HR42 | M8 | 1/4 ^b | ~28 | ~21 | 8000 | 0.8 | 1.8 | 148 | 21 | 9 | 19 | 10 | 1/4 | 8431 0368 22 |
| EP8PS HR10 | M8-M10 | 3/8 | ~65 | ~48 | 8000 | 1.0 | 2.2 | 158 | 23 | 9 | 19 | 10 | 1/4 | 8431 0368 24 |
| EP5XS HR42 | M5-M6 | 1/4 ^b | 5-12 | 4-9 | 8500 | 0.8 | 1.8 | 165 | 21 | 9 | 19 | 8 | 1/4 | 8431 0372 30 |
| EP6XS HR42 | M6 | 1/4 ^b | 9-19 | 6-14 | 8000 | 0.8 | 1.8 | 150 | 22 | 8 | 17 | 8 | 1/4 | 8431 0372 23 |
| EP6XS HR10 | M6 | 3/8 | 10-20 | 7-15 | 8000 | 0.8 | 1.8 | 152 | 22 | 8 | 17 | 8 | 1/4 | 8431 0372 20 |
| EP7XS HR42 | M8 | 1/4 ^b | 17-28 | 13-21 | 9000 | 0.8 | 1.8 | 150 | 22 | 8 | 17 | 8 | 1/4 | 8431 0372 10 |
| EP7XS HR10 | M8 | 3/8 | 20-31 | 15-23 | 9000 | 0.8 | 1.8 | 152 | 22 | 8 | 17 | 8 | 1/4 | 8431 0372 00 |
| EP8XS HRX42 | M8 | 1/4 ^b | 22-40 | 16-29 | 7000 | 1.0 | 2.2 | 172 | 23 | 9 | 19 | 10 | 1/4 | 8431 0369 16 |
| EP8XS HRX10 | M8-M10 | 3/8 | 30-52 | 22-38 | 7000 | 1.0 | 2.2 | 174 | 23 | 9 | 19 | 10 | 1/4 | 8431 0369 09 |
| EP10XS HR13 | M10 | 1/2 | 50-70 | 37-52 | 6000 | 1.3 | 2.9 | 168 | 26 | 11 | 23 | 10 | 1/4 | 8431 0369 40 |
| EP12XS HR13 | M12 | 1/2 | 65-110 | 48-81 | 4500 | 1.6 | 3.5 | 178 | 29 | 12 | 25 | 10 | 1/4 | 8431 0371 00 |
| EP14XS HR13 | M14 | 1/2 | 110-160 | 81-118 | 3500 | 2.4 | 5.3 | 188 | 34 | 14 | 30 | 13 | 3/8 | 8431 0371 50 |
| EP16XS HR20 | M16 | 3/4 | 160-240 | 118-177 | 2800 | 3.3 | 7.3 | 205 | 37 | 15 | 32 | 13 | 3/8 | 8431 0371 55 |
| EP20XS HR20 | M20 | 3/4 | 300-400 | 221-295 | 3700 | 5.1 | 11.2 | 240 | 43 | 16 | 34 | 13 | 3/8 | 8431 0371 60 |

^a To be used as a guide only, final torque depends on type of joint, accessories used and air pressure.

^b Female hexagon drive. Quick change chuck.

^c Torque is adjusted by regulating the air pressure.

EP PTX MODELS

In ErgoPulse shut-off tools the air supply is shut off as soon as the pre-set torque has been reached, minimizing operator influence. The result is increased accuracy and faster tightening.

- High reliability.
- Consistent torque over time, low mean-shift.
- High level of durability.
- High speed, short cycle times.
- One-handed operation.
- High power-to-weight ratio.
- No springs to wear out.
- High precision components.
- No reaction forces.
- Low noise levels.
- Lubrication free.



| Model | Bolt size mm | Square drive in | Torque range ^a | | Free speed r/min | Weight | | Length mm | CS distance mm | Air consumption under load ^a | | Rec. hose size mm | Air inlet thread in | Ordering No. |
|-------------------------------------|-----------------|--------------------|---------------------------|---------|---------------------|--------|------|--------------|-------------------|---|-----|----------------------|------------------------|--------------|
| | | | Nm | ft lb | | kg | lb | | | l/s | cfm | | | |
| TRIM | | | | | | | | | | | | | | |
| EP3PTX5 SR42 | M4-M5 | 1/4 ^b | 2-5 | 1.6-4 | 4500 ^d | 0.7 | 1.6 | 202 | 21 | 4 | 9 | 8 | 1/4 | 8431 0376 01 |
| EP4PTX9 SR10 | M5 | 3/8 | 4-9 | 3-7 | 3400 ^d | 0.9 | 2.0 | 207 | 21 | 4 | 9 | 8 | 1/4 | 8431 0376 04 |
| EP4PTX9 SR42 | M5 | 1/4 ^b | 4-9 | 3-7 | 3400 ^d | 0.9 | 2.0 | 207 | 21 | 4 | 9 | 8 | 1/4 | 8431 0376 00 |
| EP5PTX14 SR42 | M6 | 1/4 ^b | 7-14 | 5-10 | 5300 ^d | 0.9 | 2.0 | 207 | 21 | 7 | 15 | 8 | 1/4 | 8431 0376 10 |
| EP5PTX15 SR10 | M6 | 3/8 | 9-15 | 7-11 | 5300 ^d | 0.9 | 2.0 | 207 | 21 | 7 | 15 | 8 | 1/4 | 8431 0376 14 |
| EP6PTX18 SR42 | M6 | 1/4 ^b | 9-18 | 7-13 | 6800 ^d | 0.9 | 2.0 | 207 | 21 | 7 | 15 | 8 | 1/4 | 8431 0376 20 |
| EP6PTX19 SR10 | M6 | 3/8 | 10-19 | 7-14 | 6800 ^d | 0.9 | 2.0 | 207 | 21 | 7 | 15 | 8 | 1/4 | 8431 0376 24 |
| EP7PTX28 SR42 | M6-M8 | 1/4 ^b | 17-28 | 13-18 | 4300 ^d | 1.2 | 2.5 | 235 | 25 | 8 | 17 | 10 | 1/4 | 8431 0376 30 |
| EP7PTX31 SR10 | M6-M8 | 3/8 | 18-31 | 13-23 | 4300 ^d | 1.2 | 2.5 | 235 | 25 | 8 | 17 | 10 | 1/4 | 8431 0376 34 |
| EP8PTX45 SR10 | M8 | 3/8 | 24-45 | 18-33 | 5500 ^d | 1.2 | 2.5 | 235 | 25 | 9 | 19 | 10 | 1/4 | 8431 0376 40 |
| EP8PTX38 SR42 | M8 | 1/4 ^b | 22-38 | 16-28 | 5500 ^d | 1.2 | 2.5 | 235 | 25 | 9 | 19 | 10 | 1/4 | 8431 0376 44 |
| TRIM-RE | | | | | | | | | | | | | | |
| EP25PTX900 GR25-RE | M24-M27 | 1 | 450-900 | 330-660 | 4500 ^d | 10.3 | 22.7 | 406 | 58.5 | 30 | 63 | 13 | 1/2 | 8431 0376 90 |
| AutoTrim | | | | | | | | | | | | | | |
| EP3PTX5 SR42-AT | M4-M5 | 1/4 ^b | 2-5 | 1.6-4 | 4500 ^c | 0.8 | 1.7 | 262 | 21 | 4 | 9 | 8 | 1/4 | 8431 0376 03 |
| EP4PTX9 SR10-AT | M5 | 3/8 | 4-9 | 3-7 | 3300 ^c | 0.9 | 2.0 | 267 | 21 | 4 | 9 | 8 | 1/4 | 8431 0376 06 |
| EP4PTX9 SR42-AT | M5 | 1/4 ^b | 4-9 | 3-7 | 3300 ^c | 0.9 | 2.0 | 267 | 21 | 4 | 9 | 8 | 1/4 | 8431 0376 02 |
| EP5PTX15 SR10-AT | M6 | 3/8 | 9-15 | 7-11 | 4800 ^c | 0.9 | 2.0 | 267 | 21 | 7 | 15 | 8 | 1/4 | 8431 0376 16 |
| EP5PTX14 SR42-AT | M6 | 1/4 ^b | 7-14 | 5-10 | 4800 ^c | 0.9 | 2.0 | 267 | 21 | 7 | 15 | 8 | 1/4 | 8431 0376 12 |
| EP6PTX18 SR42-AT | M6 | 1/4 ^b | 9-18 | 7-13 | 6700 ^c | 0.9 | 2.0 | 267 | 21 | 7 | 15 | 8 | 1/4 | 8431 0376 22 |
| EP6PTX19 SR10-AT | M6 | 3/8 | 10-19 | 7-14 | 6700 ^c | 0.9 | 2.0 | 267 | 21 | 7 | 15 | 8 | 1/4 | 8431 0376 26 |
| EP7PTX28 SR42-AT | M6-M8 | 1/4 ^b | 17-28 | 13-18 | 4300 ^c | 1.2 | 2.5 | 295 | 25 | 7 | 15 | 10 | 1/4 | 8431 0376 32 |
| EP7PTX31 SR10-AT | M6-M8 | 3/8 | 18-31 | 13-23 | 4300 ^c | 1.2 | 2.5 | 295 | 25 | 7 | 15 | 10 | 1/4 | 8431 0376 36 |
| EP8PTX38 SR42-AT | M8 | 1/4 ^b | 22-38 | 16-28 | 5900 ^c | 1.2 | 2.5 | 295 | 25 | 9 | 19 | 10 | 1/4 | 8431 0376 46 |
| EP8PTX45 SR10-AT | M8 | 3/8 | 24-45 | 18-33 | 5900 ^c | 1.2 | 2.5 | 295 | 25 | 9 | 19 | 10 | 1/4 | 8431 0376 42 |
| AutoTrim Low pressure models | | | | | | | | | | | | | | |
| EP5PTX SR10-AT-L | M5 | 3/8 | 8-13 | 6-10 | 4800 ^e | 0.9 | 2.0 | 267 | 21 | 4 | 9 | 8 | 1/4 | 8431 0368 01 |
| EP5PTX SR42-AT-L | M4-M5 | 1/4 ^b | 7-12 | 5-9 | 4800 ^e | 0.7 | 1.6 | 267 | 21 | 4 | 9 | 8 | 1/4 | 8431 0368 03 |
| EP6PTX SR10-AT-L | M6 | 3/8 | 10-17 | 7-13 | 6300 ^e | 0.9 | 2.0 | 267 | 21 | 7 | 15 | 8 | 1/4 | 8431 0368 09 |
| EP6PTX SR42-AT-L | M5 | 1/4 ^b | 9-16 | 6-12 | 6300 ^e | 0.9 | 2.0 | 267 | 21 | 4 | 9 | 8 | 1/4 | 8431 0368 15 |
| EP7PTX SR10-AT-L | M6 | 3/8 | 16-22 | 12-16 | 4000 ^e | 0.9 | 2.0 | 295 | 21 | 7 | 15 | 8 | 1/4 | 8431 0368 35 |
| EP7PTX SR42-AT-L | M6 | 1/4 ^b | 15-21 | 11-15 | 4000 ^e | 0.9 | 2.0 | 295 | 21 | 7 | 15 | 8 | 1/4 | 8431 0368 46 |
| EP8PTX SR10-AT-L | M6-M8 | 3/8 | 21-32 | 15-24 | 5300 ^e | 1.2 | 2.5 | 295 | 25 | 8 | 17 | 10 | 1/4 | 8431 0367 83 |

^a To be used as a guide only, final torque depends on type of joint, accessories used and air pressure.

^d With TRIM valve fully open.

^e Measured at 5 bar air pressure.

^b Female hexagon drive. Quick change chuck.

^c In full speed mode.

XS MODELS

In ErgoPulse non shut-off tools the tool produces pulses until the operator releases the trigger. Preferred in applications where it is an advantage for the operator to be able to control the process by shutting off the tool manually.

- High reliability and durability.
- High speed, short cycle times.
- One-handed operation.
- High power-to-weight ratio.
- No springs to wear out.
- No wear on key parts.
- High precision components.
- No reaction forces.
- Light, well-balanced tools.
- Low noise levels.
- Lubrication free.



| Model | Bolt size mm | Square drive in | Torque range ^a | | Free speed r/min | Weight | | Length mm | CS distance mm | Air consumption under load | | Rec. hose size mm | Air inlet thread in | Ordering No. |
|------------|--------------|------------------|---------------------------|-------|------------------|--------|-----|-----------|----------------|----------------------------|-----|-------------------|---------------------|--------------|
| | | | Nm | ft lb | | kg | lb | | | l/s | cfm | | | |
| EP6XS SR10 | M6 | 3/8 | 10-20 | 7-15 | 8000 | 0.7 | 1.5 | 221 | 22 | 8 | 17 | 8 | 1/4 | 8431 0372 25 |
| EP6XS SR42 | M6 | 1/4 ^b | 9-19 | 6-14 | 8000 | 0.7 | 1.5 | 219 | 22 | 8 | 17 | 8 | 1/4 | 8431 0372 27 |
| EP7XS SR10 | M8 | 3/8 | 20-31 | 15-23 | 10000 | 0.7 | 1.5 | 221 | 22 | 8 | 17 | 8 | 1/4 | 8431 0372 05 |
| EP7XS SR42 | M8 | 1/4 ^b | 17-28 | 13-21 | 10000 | 0.7 | 1.5 | 219 | 22 | 8 | 17 | 8 | 1/4 | 8431 0372 15 |
| EP8XS SR10 | M8-M10 | 3/8 | 30-52 | 22-38 | 8000 | 0.9 | 2.0 | 244 | 24 | 9 | 19 | 8 | 1/4 | 8431 0369 20 |
| EP8XS SR42 | M8 | 1/4 ^b | 22-40 | 16-29 | 8000 | 0.9 | 2.0 | 242 | 24 | 9 | 19 | 8 | 1/4 | 8431 0369 30 |

^a To be used as a guide only, final torque depends on type of joint, accessories used and air pressure.

^b Female hexagon drive. Quick change chuck.

Productivity Kits

| Model | Max air flow | Hose 16.4 ft | Coupling | Lubrication | Ordering No. |
|--|--------------|--------------|--------------|-------------|--------------|
| For small impact wrenches and pulse tools | | | | | |
| MIDI Optimizer F/RD EP EQ08US-C08 | 19 cfm | Cablar 08 | ErgoQIC 08US | Yes | 8202 0850 45 |
| For 1/2" impact wrenches and pulse tools | | | | | |
| MIDI Optimizer F/RD EP EQ10US-C10 | 34 cfm | Cablar 10 | ErgoQIC 10US | Yes | 8202 0850 46 |
| For impact wrenches and pulse tools | | | | | |
| MIDI Optimizer F/RD EP EQ10US-C13 | 50 cfm | Cablar 13 | ErgoQIC 10US | Yes | 8202 0850 47 |
| MIDI Optimizer F/RD EP EQ10US-T13 | 65 cfm | Turbo 13 | ErgoQIC 10US | Yes | 8202 0850 48 |

Optional Accessories

GUIDED EXTENSIONS

| Available for | Square drive in | Dia. of outgoing spindle mm | Length mm | Marking | Ordering No. |
|---|-----------------|-----------------------------|-----------|-----------|--------------|
| 6-8XS, 5-8PT/PTS/PTX | 3/8 | 13 | 75 | 10-13-75 | 4023 3600 02 |
| | 3/8 | 13 | 100 | 10-13-100 | 4023 3600 01 |
| | 3/8 | 13 | 150 | 10-13-150 | 4023 3601 01 |
| | 3/8 | 13 | 200 | 10-13-200 | 4023 3611 01 |
| | 3/8 | 13 | 250 | 10-13-250 | 4023 3612 01 |
| | 3/8 | 13 | 300 | 10-13-300 | 4023 3613 01 |
| 10C, 10-12XS | 1/2 | 16 | 75 | 13-16-75 | 4023 3602 02 |
| | 1/2 | 16 | 100 | 13-16-100 | 4023 3602 01 |
| | 1/2 | 16 | 150 | 13-16-150 | 4023 3603 01 |
| | 1/2 | 16 | 200 | 13-16-200 | 4023 3604 01 |
| | 1/2 | 16 | 250 | 13-16-250 | 4023 3614 01 |
| | 1/2 | 16 | 300 | 13-16-300 | 4023 3615 01 |
| 14XS, 9-13PTX, 10-12PT/PTS | 1/2 | 18 | 75 | 13-18-75 | 4023 3605 02 |
| | 1/2 | 18 | 100 | 13-18-100 | 4023 3605 01 |
| | 1/2 | 18 | 150 | 13-18-150 | 4023 3606 01 |
| | 1/2 | 18 | 200 | 13-18-200 | 4023 3607 01 |
| | 1/2 | 18 | 250 | 13-18-250 | 4023 3616 01 |
| | 1/2 | 18 | 300 | 13-18-300 | 4023 3617 01 |
| 16XS/20XS, 14PTS/18PTS, 15PTX/19PTX | 3/4 | 25 | 100 | 20-25-100 | 4023 3608 01 |
| | 3/4 | 25 | 150 | 20-25-150 | 4023 3609 01 |
| | 3/4 | 25 | 200 | 20-25-200 | 4023 3610 01 |
| | 3/4 | 25 | 250 | 20-25-250 | 4023 3618 01 |
| | 3/4 | 25 | 300 | 20-25-300 | 4023 3619 01 |



Guided extensions

GUIDED SOCKETS

| Available for | Square in | Width across mm/in | Diameter of outgoing mm | Marking | Ordering No. |
|---|-----------|--------------------|-------------------------|----------|--------------|
| Metric sockets | | | | | |
| 6-8XS, 5-8PT/PTS/PTX | 3/8 | 10 | 13 | 10-13 | 4026 4210 00 |
| | 3/8 | 13 | 13 | 13-13 | 4026 4213 00 |
| | 3/8 | 16 | 13 | 16-13 | 4026 4216 00 |
| | 3/8 | 17 | 13 | 17-13 | 4026 4217 00 |
| | 3/8 | 18 | 13 | 18-13 | 4026 4218 00 |
| | 3/8 | 19 | 13 | 19-13 | 4026 4219 00 |
| 14XS, 9-13PTX, 10-12PT/PTS | 1/2 | 13 | 18 | 13-18 | 4026 4313 00 |
| | 1/2 | 16 | 18 | 16-18 | 4026 4316 00 |
| | 1/2 | 17 | 18 | 17-18 | 4026 4317 00 |
| | 1/2 | 18 | 18 | 18-18 | 4026 4318 00 |
| | 1/2 | 19 | 18 | 19-18 | 4026 4319 00 |
| | 1/2 | 24 | 18 | 24-18 | 4026 4324 00 |
| 16XS/20XS, 14PTS/18PTS, 15PTX/19PTX | 3/4 | 18 | 25 | 18-25 | 4026 4418 00 |
| | 3/4 | 24 | 25 | 24-25 | 4026 4424 00 |
| | 3/4 | 30 | 25 | 30-25 | 4026 4430 00 |
| UNC/UNF-sockets | | | | | |
| 6-8XS, 5-8PT/PTS/PTX | 3/8 | 1/2 | 13 | 1/2-13 | 4026 4212 00 |
| | 3/8 | 9/16 | 13 | 9/16-13 | 4026 4214 00 |
| | 3/8 | 3/4 | 13 | 3/4-13 | 4026 4219 00 |
| 14XS, 9-13PTX, 10-12PT/PTS | 1/2 | 1/2 | 18 | 1/2-18 | 4026 4312 00 |
| | 1/2 | 9/16 | 18 | 9/16-18 | 4026 4314 00 |
| | 1/2 | 3/4 | 18 | 3/4-18 | 4026 4319 00 |
| | 1/2 | 15/16 | 18 | 15/16-18 | 4026 4323 00 |
| 16XS/20XS, 14PTS/18PTS, 15PTX/19PTX | 3/4 | 3/4 | 25 | 3/4-25 | 4026 4419 00 |
| | 3/4 | 15/16 | 25 | 15/16-25 | 4026 4423 00 |
| | 3/4 | 11/8 | 25 | 11/8-25 | 4026 4429 00 |



Guided sockets

Optional Accessories

GUIDED QUICK CHANGE CHUCK FOR POWER TOOLS

| Available for | Square drive in | Female hex in | Diameter of outgoing spindle mm | Marking | Ordering No. |
|-------------------------------|-----------------|---------------|---------------------------------|---------------------------|------------------------------|
| 6-8XS, 5-8PT/PTS/PTX | 3/8 | 1/4 7/16 | 13 | 3/8-1/4-13 3/8-7/16-13 | 4026 4501 00 4026 4502 00 |
| 14XS, 9-13PTX, 10-12PT/PTS | 1/2 | 7/16 | 18 | 1/2-7/16-18 | 4026 4503 00 |



Guided quick change chuck

RE-REPORTING KIT

| | Ordering No. |
|--|--------------|
| RE-reporting kit for ErgoPulse PTS/PTX models with AutoTrim or Trim-RE valve | 4250 1854 91 |

PROTECTIVE COVER AND SUPPORT HANDLE

| Pistol grip models | Protective cover | Support handle |
|--------------------|------------------|----------------|
| EP6/7XS HR | 4250 2089 00 | |
| EP8XS HRX | 4250 1895 00 | |
| EP10XS HR | 4250 1784 00 | |
| EP12XS HR | 4250 2459 00 | |
| EP14XS HR | 4250 2160 00 | |
| EP16XS HR | 4250 2282 00 | 4250 2396 91 |
| EP20XS HR | 4250 2288 00 | Included |
| EP4/5/6PTX HR | 4250 2465 00 | |
| EP7/8PTX HR | 4250 2466 00 | |
| EP9PTX HR | 4250 2467 00 | |
| EP11PTX HR | 4250 2551 00 | |
| EP13PTX HR | 4250 2718 00 | 4250 2396 81 |
| EP15PTX HR | 4250 2674 00 | 4250 2396 83 |
| EP19PTX HR | 4250 2719 00 | 4250 2396 82 |
| EP5/6PT/PTS HR | 4250 2393 00 | |
| EP7/8PT/PTS HR | 4250 1784 00 | |
| EP10PT/PTS HR | 4250 1743 00 | |
| EP12PT/PTS HR | 4250 1858 00 | |
| EP14PTS HR | 4250 2228 00 | 4250 2396 91 |
| EP18PTS HR | 4250 2319 00 | |



Support handle



Protective cover

For complete information, see spare parts list.



Service Kits

The spare parts included in the service kits cover a normal overhaul of your tool. Always have them available for a fast and economical repair.

Main parts included:

- Vane kit
- Motor bearings
- Gaskets
- O-rings
- Circlips
- Pins etc.

| Model | Pulse unit kit | Service kit | Model | Pulse unit kit | Service kit |
|------------------------------------|----------------|--------------|-------------|----------------|--------------|
| EP5XS | 4210 2532 93 | 4081 0264 90 | EP7PTX HR | 4250 2267 96 | 4081 0410 90 |
| EP6/7XS HR | 4250 2084 90 | 4081 0188 90 | EP8PTX HR | 4250 2267 91 | 4081 0279 90 |
| EP6/7XS SR | 4250 2084 90 | 4081 0189 90 | EP9PTX HR | 4250 2058 90 | 4081 0411 90 |
| EP6PS HR | 4250 2058 91 | 4081 0274 90 | EP11PTX HR | 4250 2267 95 | 4081 0310 90 |
| EP8PS HR | 4250 2059 90 | 4081 0120 90 | EP13PTX HR | 4250 2267 92 | 4081 0226 90 |
| EP8XS HR | 4250 2085 90 | 4081 0119 90 | EP15PTX HR | 4250 2267 93 | 4081 0242 90 |
| EP8XS SR | 4250 2085 90 | 4081 0190 90 | EP19PTX HR | 4250 2267 94 | 4081 0256 90 |
| EP10XS HR | 4250 2086 90 | 4081 0191 90 | EP25PTX GR | 4250 2267 97 | 4081 0427 90 |
| EP12XS HR | 4250 2087 90 | 4081 0192 90 | EP5/6PTS HR | 4250 2058 90 | 4081 0413 90 |
| EP14XS HR | 4250 2170 90 | 4081 0200 90 | EP7/8PTS HR | 4250 2267 91 | 4081 0225 90 |
| EP16XS HR | 4250 2281 90 | 4081 0223 90 | EP10PTS HR | 4250 2267 90 | 4081 0222 90 |
| EP20XS HR | 4250 2281 91 | 4081 0245 90 | EP12PTS HR | 4250 2267 92 | 4081 0226 90 |
| EP4PTX HR | 4250 2058 96 | 4081 0122 90 | EP14PTS HR | 4250 2267 93 | 4081 0242 90 |
| EP5/6PTX HR | 4250 2058 90 | 4081 0122 90 | EP18PTS HR | 4250 2267 94 | 4081 0256 90 |
| Oil filling kit (50 ml, syringe) | | 4081 0121 90 | | | |
| Oil filling kit (1000 ml, syringe) | | 4081 0513 90 | | | |

For complete information, see spare parts list.

An impulse tool with fastening system intelligence

Atlas Copco's Pulsor C System gives you all the advantages of a controlled impulse tool, plus the intelligence of an electric fastening system. Like all Atlas Copco impulse tools, Pulsor C is fast, powerful, light and compact and generates virtually no reaction force. The controller remembers up to 4,000 tightenings that can be stored and analyzed. This enables you to fine-tune your process and ensure that every tightening in every shift is perfect. If they are not perfect, you can see why.

The Pulsor C, with its control system, is designed for quality critical applications. Pulsor C alerts you to mistakes as soon as they are made. Lights on the back of the tool indicate if screws are correctly tightened. They inform the user about torque, early shut-off or if parts have been forgotten. Pulsor C will control repeatability and can report results.

THE SYSTEM

The Pulsor C system comprises the tool, cable, controller and tool control box where the shut-off valve is located.

THE TOOL

Pulsor C tools are an ergonomic, high-performance range of impulse nutrunners with signal lights to provide direct operator feedback. No mechanical torque setting in tool.

CABLES

The strong, resistant electric tool cable is available in three versions: straight, coil and spiral.

TOOL CONTROL BOX

Pressure adjustment and tool shut-off valves are located in this box.

CONTROLLER

The controller remembers up to 4,000 tightenings – everything from torque results and rundown time to identification number (see below for a full list of parameters). The results can easily be sent to a network and stored on a server as for example ToolsNet. They can also be transferred directly to a PC and then analyzed in a program such as Excel. This means that you can easily fine-tune your process.

Pulsor monitors and records:

- Torque result
- Angle result
- Premature shut-off
- Number of pulses
- Tightening time
- Rundown time
- Barcode number

SOFTWARE

The PC based ToolsTalk Pulsor C software is used for making all system settings.

- Tool settings
- Communication settings to factory networks



The Pulsor C tool is fast and powerful. It is also light, compact and generates virtually no reaction force, making it a very comfortable tool to work with.

- Fast rundown. Up to 9000 rpm for highest productivity.
- No need for reaction arm. Virtually no reaction force due to pulse tightening.
- Avoid downtime. Get an early warning with Tool drift alarm.
- Easy to service. Patented pulse technology with few parts.
- Plan service with service alarms.
- Illumination of working area with bright LED.
- Operator feedback after tightening with LED lights (OK/NOK).



EPP10 C

| Model | Bolt size mm | Square drive in | Torque range | | Free speed r/min | Weight | | Length mm | CS distance mm | Air consumption under load | | Rec. hose size mm | Air inlet thread in | Ordering No. |
|--|-----------------|--------------------|--------------|---------|---------------------|--------|-----|--------------|-------------------|----------------------------|-----|----------------------|------------------------|--------------|
| | | | Nm | ft lb | | kg | lb | | | l/s | cfm | | | |
| Tools with ball retainer | | | | | | | | | | | | | | |
| EPP6 C40 HR-B10 | M6-M8 | 3/8 | 20-40 | 15-30 | 9000 | 1.3 | 2.8 | 164 | 23 | 7 | 15 | 10 | 1/4 | 8431 0380 53 |
| EPP8 C55 HR-B10 | M8-M10 | 3/8 | 30-55 | 22-40 | 7000 | 1.5 | 3.4 | 172 | 26 | 8 | 17 | 10 | 1/4 | 8431 0380 59 |
| EPP10 C90 HR-B13 | M10 | 1/2 | 45-90 | 33-66 | 5500 | 2 | 4.5 | 184 | 30 | 11 | 23 | 10 | 1/4 | 8431 0380 64 |
| EPP11 C110 HR-B13 | M12 | 1/2 | 55-110 | 40-80 | 5100 | 2.1 | 4.6 | 192 | 30 | 12 | 25 | 13 | 1/4 | 8431 0380 68 |
| Tools with pin retainer | | | | | | | | | | | | | | |
| EPP6 C40 HR10 | M6-M8 | 3/8 | 20-40 | 15-30 | 9000 | 1.3 | 2.8 | 164 | 23 | 7 | 15 | 10 | 1/4 | 8431 0380 46 |
| EPP8 C55 HR10 | M8-M10 | 3/8 | 30-55 | 22-40 | 7000 | 1.5 | 3.4 | 172 | 26 | 8 | 17 | 10 | 1/4 | 8431 0380 57 |
| EPP10 C90 HR13 | M10 | 1/2 | 45-90 | 33-66 | 5500 | 2 | 4.5 | 184 | 30 | 11 | 23 | 10 | 1/4 | 8431 0380 62 |
| EPP11 C110 HR13 | M12 | 1/2 | 55-110 | 40-80 | 5100 | 2.1 | 4.6 | 192 | 30 | 12 | 25 | 13 | 1/4 | 8431 0380 66 |
| EPP13 C150 HR13 | M12-M14 | 1/2 | 75-150 | 55-110 | 5300 | 2.6 | 5.7 | 193 | 33.5 | 15 | 32 | 13 | 3/8 | 8431 0380 71 |
| Tools with through hole in square drive | | | | | | | | | | | | | | |
| EPP15 C250 HR20 | M12-M16 | 3/4 | 125-250 | 92-184 | 4300 | 3.3 | 7.3 | 211 | 37 | 21 | 44 | 13 | 3/8 | 8431 0380 77 |
| EPP19 C400 HR20 | M16-M20 | 3/4 | 200-400 | 148-295 | 3300 | 4.5 | 9.9 | 217 | 44 | 23 | 49 | 13 | 3/8 | 8431 0380 82 |

CONTROLLER SOFTWARE

Pulsor's functionality is unlocked with the RBU (Rapid Backup Unit) key. This patented device gives you access to the functionality you need while providing a backup for the data you have programmed yourself.

| Function | RBU Gold |
|--|-----------|
| Number of results in the result database | 4000 |
| Tool Setup | Yes |
| Tool Lock Box | Yes |
| Network/TCP/IP | Yes |
| I/O-bus (CAM-cabel) | Yes |
| Click wrench | Yes |
| ToolsNet | Yes |
| Number of Psets | up to 100 |
| Number of jobs | up to 100 |
| Statistics | Yes |
| Number of events | 500 |
| Barcode reader | Yes |
| Tool drift alarm | Yes |

Optional Accessories

TOOL ACCESSORIES

| Model | Ordering No. |
|---|--------------|
| Controllers | |
| Pulsor Focus 4000-C-HW | 8433 6900 20 |
| Pulsor Focus 4000-C-DN-HW | 8433 6940 20 |
| Pulsor Focus 4000-C-PB-HW | 8433 6942 20 |
| Pulsor Focus 4000-C-PN-HW | 8433 6948 20 |
| Pulsor Focus 4000-C-EIP-HW | 8433 6949 20 |
| Pulsor Focus 4000-C-IB-HW | 8433 6945 20 |
| Tool Control Box | |
| TCB-1E | 8433 0606 40 |
| RBU | |
| Pulsor C - Gold | 8433 6020 20 |
| TCB cables | |
| Cable PF - TCB, 1.2 m | 4250 2901 01 |
| Cable PF - TCB, 5 m | 4250 2901 05 |
| Cable PF - TCB, 10 m | 4250 2901 10 |
| Tool cables | |
| Straight 5 m | 4250 2533 05 |
| 12 m | 4250 2533 12 |
| Spiral 5 m | 4250 2533 06 |
| 12 m | 4250 2533 13 |
| Coil 3 m | 4250 2533 53 |
| 5 m | 4250 2533 55 |
| 7 m | 4250 2533 57 |
| Back plate (for attaching PF and TCB in one plate) | |
| | 4250 2829 90 |
| PCU - Pulsor Control Unit (Includes: controller, RBU, TCB, back plate, cable 1.2 m) | |
| PCU | 8433 6990 30 |
| ToolsTalk Pulsor C, W10 | |
| 1-user license | 8092 1292 01 |
| 5-user license | 8092 1292 05 |
| 10-user license | 8092 1292 10 |
| Plant license | 8092 1292 99 |
| Suspension yoke (for upside down hanging, all models) | |
| | 4250 2720 00 |



Pulsor Focus



Tool Control Box (TCB)



Coil cable



Straight cable



Spiral cable



Selector 4

CONTROLLER ACCESSORIES

| Model | Ordering No. |
|-------------------------|--------------|
| Rotary selector | 8433 0606 15 |
| I/O Expander | 8433 0564 39 |
| RE-Alarm | 8433 0560 03 |
| Selector 4 | 8433 0610 04 |
| Selector 8 | 8433 0610 08 |
| Operator panel basic | 8433 0565 10 |
| Operator panel advanced | 8433 0565 00 |
| Stacklights | |
| ESL-04 Standard | 8433 0570 13 |
| Rotating red | 8433 0570 30 |
| Rotating yellow | 8433 0570 35 |
| Siren | 8433 0570 40 |
| Compact | 8433 0570 16 |
| DSL-03 with push button | 8433 0570 10 |
| with blanking plugs | 8433 0570 11 |



Stacklight DSL-03



Operator panel Basic

TOOL HOSE KITS

| Model | Hose kit | Ordering No. |
|--------------------|-------------------------|--------------|
| Hoses 16 ft | | |
| EPP6 – EPP10 | PVC 10 + Ergo couplings | 8202 1180 10 |
| EPP11 | PVC 13 + Ergo couplings | 8202 1180 11 |
| EPP13 – EPP19 | PVC 13 + Ergo couplings | 8202 1180 12 |
| Hoses 32 ft | | |
| EPP6 – EPP10 | PVC 10 + Ergo couplings | 8202 1180 13 |
| EPP11 | PVC 13 + Ergo couplings | 8202 1180 14 |
| EPP13 – EPP19 | PVC 13 + Ergo couplings | 8202 1180 15 |

User-friendly tools offering power, speed and accuracy

The tools in Atlas Copco's broad range of pneumatic nutrunners offer a superior combination of power, speed and accuracy. With their advanced ergonomic designs, they are also extremely user-friendly and will contribute to raising productivity in a wide range of applications in your assembly plant.

Tools in Atlas Copco's range of pneumatic nutrunners are divided into three main categories: Angle, straight and pistol grip versions. These are also available in optional models, such as crowfoot, hold-and-drive, and flush socket.

THE POWER TO RAISE PRODUCTIVITY

The high power output provided by Atlas Copco nutrunners is decisive for productivity, i.e., the combined performance of operator and tool. The tools are set at the optimal speed for every torque capacity rating. The balance between speed and clutch response gives high accuracy, ensuring torque repeatability, regardless of joint characteristics.

COMFORTABLE TO WORK WITH

Our pneumatic nutrunners live up to Atlas Copco's reputation for developing tools with good ergonomics. Low tool weights, thermally insulated grips and low noise and vibration levels all help to reduce operator fatigue and raise individual productivity in your plant.

Simplicity in selection and installation allow you to set the torque once and that is the torque you will get, joint after joint, without complicated analyses.

CHOOSING THE RIGHT TOOL IS EASY

No joint is too complicated for a nutrunner. To set the torque, just adjust it to the required level, regardless of joint conditions.



A new angle on productivity

The LTV 9-2 and LTV 8 angle nutrunner range from Atlas Copco successfully combines two key performance factors – speed and accuracy. Consistently accurate, high-speed tightening is complemented by advanced ergonomic design, ensuring an unmatched level of productivity. All this is presented in a tool that is very easy to handle.

Angle nutrunners from Atlas Copco are certified for accuracy and durability by major car manufacturers. They are easy to choose, easy to set, and easy to operate.

ACCURATE EVERY TIME

Hard or soft joint? You don't need to think about it. The tool gives the torque you install, independent of joint variations and variations in air pressure and lubrication. The clutch shuts off at the same torque, tightening after tightening.

HIGHEST PRODUCTIVITY

Instant disengagement of the clutch keeps torque over-shoot to a minimum even on the fastest tools. Our new models were developed to meet the most extreme requirements on operational speeds.

As always, we kept operator comfort in mind. The tools are well balanced, slim and comfortable to handle. Reaction forces are extremely low.

JOB VERIFICATION

For remote indication of clutch release function the tools can be equipped with air signal outlet – RE. This is often used for counting the number of fasteners in a tightening cycle.



LTV29-2 SERIES

- Designed for high speed and small dimensions.
- Slim lightweight design.
- Soft, comfortable grip.
- Easy to reverse.
- Low reaction force.
- Spiral cut angle gears



LTV29-2

LTV39-2 SERIES

- The fastest nutrunners of this type.
- Powerful motor.
- Consistently high accuracy.
- Many operator-friendly features.
- Spiral cut angle gears



LTV39-2

LTV FS FLUSH SOCKET TOOLS

- Minimum angle head size gives good access.
- High torque accuracy.
- Integrated sockets give reduced angle head height.
- Spiral cut angle gears

| Model | Bolt size mm | Square drive in | Torque range soft joint | | Free speed r/min | Weight | | Length mm | Angle head height mm | Angle head center to side mm | Air consumption at free speed | | Rec. hose size mm | Air inlet thread in | Ordering No. |
|---------------------|--------------|------------------|-------------------------|-------|------------------|--------|-----|-----------|----------------------|------------------------------|-------------------------------|-----|-------------------|---------------------|--------------|
| | | | Nm | ft lb | | kg | lb | | | | l/s | cfm | | | |
| Reversible | | | | | | | | | | | | | | | |
| LTV29-2 R12-6 | M6 | 1/4 | 6-12 | 4.5-9 | 850 | 1.3 | 2.9 | 351 | 27 | 11 | 10 | 21 | 10 | 1/4 | 8431 0631 15 |
| LTV29-2 R12-10 | M6 | 3/8 | 6-12 | 4.5-9 | 850 | 1.3 | 2.9 | 351 | 27 | 11 | 10 | 21 | 10 | 1/4 | 8431 0631 16 |
| LTV29-2 R12-Q | M6 | 1/4 ^a | 6-12 | 4.5-9 | 850 | 1.3 | 2.9 | 351 | 44 | 11 | 10 | 21 | 10 | 1/4 | 8431 0631 17 |
| LTV29-2 R12-42 | M6 | 1/4 ^b | 6-12 | 4.5-9 | 850 | 1.3 | 2.9 | 351 | 34 | 11 | 10 | 21 | 10 | 1/4 | 8431 0631 18 |
| LTV29-2 R12-B6 | M6 | 1/4 | 6-12 | 4.5-9 | 850 | 1.3 | 2.9 | 351 | 27 | 11 | 10 | 21 | 10 | 1/4 | 8431 0631 00 |
| LTV29-2 R12-B10 | M6 | 3/8 | 6-12 | 4.5-9 | 850 | 1.3 | 2.9 | 351 | 27 | 11 | 10 | 21 | 10 | 1/4 | 8431 0631 01 |
| LTV29-2 R16-6 | M6 | 1/4 | 9-16 | 7-12 | 850 | 1.3 | 2.9 | 351 | 27 | 11 | 10 | 21 | 10 | 1/4 | 8431 0631 22 |
| LTV29-2 R16-10 | M6 | 3/8 | 9-16 | 7-12 | 850 | 1.3 | 2.9 | 351 | 27 | 11 | 10 | 21 | 10 | 1/4 | 8431 0631 21 |
| LTV29-2 R16-Q | M6 | 1/4 ^a | 9-16 | 7-12 | 850 | 1.3 | 2.9 | 351 | 44 | 11 | 10 | 21 | 10 | 1/4 | 8431 0631 24 |
| LTV29-2 R16-42 | M6 | 1/4 ^b | 9-16 | 7-12 | 850 | 1.3 | 2.9 | 351 | 34 | 11 | 10 | 21 | 10 | 1/4 | 8431 0631 23 |
| LTV29-2 R16-B6 | M6 | 1/4 | 9-16 | 7-12 | 850 | 1.3 | 2.9 | 351 | 27 | 11 | 10 | 21 | 10 | 1/4 | 8431 0631 02 |
| LTV29-2 R16-B10 | M6 | 3/8 | 9-16 | 7-12 | 850 | 1.3 | 2.9 | 351 | 27 | 11 | 10 | 21 | 10 | 1/4 | 8431 0631 03 |
| LTV29-2 R24-10 | M8 | 3/8 | 12-24 | 9-18 | 640 | 1.4 | 3.1 | 374 | 30 | 14 | 10 | 21 | 10 | 1/4 | 8431 0631 29 |
| LTV29-2 R24-B10 | M8 | 3/8 | 12-24 | 9-18 | 640 | 1.4 | 3.1 | 374 | 30 | 14 | 10 | 21 | 10 | 1/4 | 8431 0631 04 |
| LTV29-2 R30-10 | M8 | 3/8 | 15-30 | 11-22 | 500 | 1.4 | 3.1 | 374 | 30 | 14 | 10 | 21 | 10 | 1/4 | 8431 0631 37 |
| LTV29-2 R30-B10 | M8 | 3/8 | 15-30 | 11-22 | 500 | 1.4 | 3.1 | 374 | 30 | 14 | 10 | 21 | 10 | 1/4 | 8431 0631 36 |
| LTV39-2 R16-10 | M6 | 3/8 | 7-16 | 5-12 | 1200 | 1.5 | 3.3 | 375 | 27 | 11 | 16 | 34 | 10 | 1/4 | 8431 0633 09 |
| LTV39-2 R16-B10 | M6 | 3/8 | 7-16 | 5-12 | 1200 | 1.5 | 3.3 | 375 | 27 | 11 | 16 | 34 | 10 | 1/4 | 8431 0631 05 |
| LTV39-2 R24-B10 | M8 | 3/8 | 12-24 | 9-18 | 870 | 1.6 | 3.5 | 385 | 30 | 14 | 16 | 34 | 10 | 1/4 | 8431 0631 06 |
| LTV39-2 R30-10 | M8 | 3/8 | 15-30 | 11-22 | 870 | 1.6 | 3.5 | 385 | 35 | 14 | 16 | 34 | 10 | 1/4 | 8431 0633 19 |
| LTV39-2 R30-B10 | M8 | 3/8 | 15-30 | 11-22 | 870 | 1.6 | 3.5 | 385 | 35 | 14 | 16 | 34 | 10 | 1/4 | 8431 0631 07 |
| LTV39-2 R37-10 | M8 | 3/8 | 22-37 | 16-27 | 708 | 1.7 | 3.7 | 405 | 35 | 18 | 16 | 34 | 10 | 1/4 | 8431 0633 24 |
| LTV39-2 R37-B10 | M8 | 3/8 | 22-37 | 16-27 | 708 | 1.7 | 3.7 | 405 | 35 | 18 | 16 | 34 | 10 | 1/4 | 8431 0631 08 |
| LTV39-2 R48-10 | M8 | 3/8 | 24-48 | 18-35 | 560 | 1.7 | 3.7 | 405 | 35 | 18 | 16 | 34 | 10 | 1/4 | 8431 0633 27 |
| LTV39-2 R48-13 | M8 | 1/2 | 24-48 | 18-35 | 560 | 2.0 | 4.4 | 425 | 41 | 20 | 16 | 34 | 10 | 1/4 | 8431 0633 43 |
| LTV39-2 R48-B10 | M8 | 3/8 | 24-48 | 18-35 | 560 | 1.7 | 3.7 | 405 | 35 | 18 | 16 | 34 | 10 | 1/4 | 8431 0631 09 |
| LTV39-2 R48-B13 | M8 | 1/2 | 24-48 | 18-35 | 560 | 2.0 | 4.4 | 425 | 41 | 20 | 16 | 34 | 10 | 1/4 | 8431 0631 10 |
| LTV39-2 R56-10 | M10 | 3/8 | 28-56 | 21-41 | 460 | 1.7 | 3.7 | 405 | 35 | 18 | 16 | 34 | 10 | 1/4 | 8431 0633 35 |
| LTV39-2 R56-13 | M10 | 1/2 | 28-56 | 21-41 | 460 | 2.0 | 4.4 | 425 | 41 | 20 | 16 | 34 | 10 | 1/4 | 8431 0633 51 |
| LTV39-2 R56-B10 | M10 | 3/8 | 28-56 | 21-41 | 460 | 1.7 | 3.7 | 405 | 35 | 18 | 16 | 34 | 10 | 1/4 | 8431 0631 11 |
| LTV39-2 R56-B13 | M10 | 1/2 | 28-56 | 21-41 | 460 | 2.0 | 4.4 | 425 | 41 | 20 | 16 | 34 | 10 | 1/4 | 8431 0631 12 |
| LTV39-2 R70-13 | M10 | 1/2 | 35-70 | 26-51 | 350 | 2.1 | 4.6 | 425 | 41 | 20 | 16 | 34 | 10 | 1/4 | 8431 0633 59 |
| LTV39-2 R70-B13 | M10 | 1/2 | 35-70 | 26-51 | 350 | 2.1 | 4.6 | 425 | 41 | 20 | 16 | 34 | 10 | 1/4 | 8431 0631 13 |
| LTV39-2 R85-13 | M10-12 | 1/2 | 43-85 | 32-63 | 305 | 2.5 | 5.5 | 500 | 52 | 25 | 16 | 34 | 10 | 1/4 | 8431 0633 67 |
| LTV39-2 R85-B13 | M10-12 | 1/2 | 43-85 | 32-63 | 305 | 2.5 | 5.5 | 500 | 52 | 25 | 16 | 34 | 10 | 1/4 | 8431 0631 14 |
| LTV39-2 R120-13 | M12 | 1/2 | 60-120 | 44-88 | 220 | 2.5 | 5.5 | 500 | 52 | 25 | 16 | 34 | 10 | 1/4 | 8431 0633 69 |
| Flush socket | | | | | | | | | | | | | | | |
| LTV29-2 R24 FS | M8 | – | 12-24 | 9-18 | 640 | 1.4 | 3.7 | 357 | 32 | 15 | 10 | 21 | 10 | 1/4 | 8431 0634 51 |
| LTV29-2 R30 FS | M8 | – | 15-30 | 11-22 | 500 | 1.3 | 3.1 | 357 | 32 | 15 | 10 | 21 | 10 | 1/4 | 8431 0634 52 |
| LTV39-2 R37 FS | M8 | – | 22-37 | 16-27 | 708 | 1.7 | 3.7 | 406 | 38 | 19 | 16 | 34 | 10 | 1/4 | 8431 0634 53 |
| LTV39-2 R48 FS | M8 | – | 24-48 | 18-35 | 560 | 1.7 | 3.7 | 406 | 38 | 19 | 16 | 34 | 10 | 1/4 | 8431 0634 54 |
| LTV39-2 R56 FS | M8 | – | 28-56 | 21-41 | 460 | 1.7 | 3.7 | 406 | 38 | 19 | 16 | 34 | 10 | 1/4 | 8431 0634 55 |
| LTV39-2 R70 FS | M10 | – | 35-70 | 26-51 | 350 | 2.1 | 4.6 | 425 | 50 | 20 | 16 | 34 | 10 | 1/4 | 8431 0634 56 |
| LTV39-2 R85 FS | M10-12 | – | 43-85 | 32-63 | 305 | 2.5 | 5.5 | 500 | 58 | 26 | 16 | 34 | 10 | 1/4 | 8431 0634 57 |
| LTV39-2 R120 FS | M12 | – | 60-120 | 44-88 | 220 | 2.5 | 5.5 | 500 | 58 | 26 | 16 | 34 | 10 | 1/4 | 8431 0634 58 |

^a Quick change chuck. ^b Female hex drive. B - Ball retainer

LTV28 AND 38 SERIES

- Highest reliability when tightening M5-M12 screws.
- Small, durable gears.
- Precise clutch.
- Reliable motor.
- Spiral cut angle gears



LTV48 SERIES

- Robust, reliable tools.
- Reversible for torques up to 200 Nm.
- Comfortable to operate due to low weight and smooth handles.
- Reaction bars and other accessories available.
- Spiral cut angle gears



LTV FS FLUSH SOCKET TOOLS

- Minimum angle head size gives good access.
- High torque accuracy.
- Integrated sockets give reduced angle head height.
- Spiral cut angle gears



| Model | Bolt size mm | Square drive in | Torque range soft joint | | Free speed r/min | Weight | | Length mm | Angle head height mm | Angle head center to side mm | Air consumption at free speed | | Rec. hose size mm | Air inlet thread in | Ordering No. |
|---------------------|--------------|------------------|-------------------------|--------|------------------|--------|-----|-----------|----------------------|------------------------------|-------------------------------|-----|-------------------|---------------------|--------------|
| | | | Nm | ft lb | | kg | lb | | | | l/s | cfm | | | |
| Reversible | | | | | | | | | | | | | | | |
| LTV28 R07-6 | M5 | 1/4 | 2.5-7 | 1.8-5 | 1100 | 1.3 | 2.9 | 334 | 28.5 | 10 | 8 | 17 | 8 | 1/4 | 8431 0601 65 |
| LTV28 R07-42 | M5 | 1/4 ^a | 2.5-7 | 1.8-5 | 1100 | 1.3 | 2.9 | 334 | 28.5 | 10 | 8 | 17 | 8 | 1/4 | 8431 0601 73 |
| LTV28 R07-Q | M6 | 1/4 ^b | 2.5-7 | 1.8-5 | 1100 | 1.3 | 2.9 | 334 | 28.5 | 10 | 8 | 17 | 8 | 1/4 | 8431 0601 68 |
| LTV28 R15-6 | M6 | 1/4 | 7-15 | 5-11 | 560 | 1.4 | 3.1 | 349 | 28 | 11 | 10 | 21 | 10 | 1/4 | 8431 0601 52 |
| LTV28 R15-10 | M6 | 3/8 | 7-15 | 5-11 | 560 | 1.4 | 3.1 | 349 | 28 | 11 | 10 | 21 | 10 | 1/4 | 8431 0601 55 |
| LTV28 R15-Q | M6 | 1/4 ^b | 7-15 | 5-11 | 560 | 1.4 | 3.1 | 349 | 28 | 11 | 10 | 21 | 10 | 1/4 | 8431 0601 53 |
| LTV28 R20-10 | M6 | 3/8 | 10-19 | 7-15 | 530 | 1.4 | 3.1 | 355 | 34.5 | 13.5 | 10 | 21 | 10 | 1/4 | 8431 0601 50 |
| LTV28 R20-42 | M6 | 1/4 ^a | 10-20 | 7-15 | 420 | 1.4 | 3.1 | 350 | 34 | 13.5 | 10 | 21 | 10 | 1/4 | 8431 0601 48 |
| LTV28 R28-10 | M8 | 3/8 | 14-28 | 10-21 | 340 | 1.4 | 3.1 | 350 | 29.5 | 13.5 | 10 | 21 | 10 | 1/4 | 8431 0601 40 |
| LTV28 R28-42 | M8 | 1/4 ^a | 14-28 | 10-21 | 340 | 1.4 | 3.1 | 350 | 29.5 | 13.5 | 10 | 21 | 10 | 1/4 | 8431 0601 44 |
| LTV28 RL28-10 | M8 | 3/8 | 14-28 | 10-21 | 80 | 1.4 | 3.1 | 350 | 29.5 | 13.5 | 10 | 21 | 10 | 1/4 | 8431 0601 33 |
| LTV38 R42-10 | M8 | 3/8 | 20-42 | 15-31 | 400 | 2.0 | 4.4 | 436 | 34.5 | 18 | 16 | 34 | 10 | 1/4 | 8431 0603 55 |
| LTV38 R42-13 | M8 | 1/2 | 20-42 | 15-31 | 400 | 2.2 | 4.8 | 453 | 41 | 20 | 16 | 34 | 10 | 1/4 | 8431 0603 69 |
| LTV38 R50-10 | M10 | 3/8 | 25-50 | 18-36 | 330 | 2.0 | 4.4 | 436 | 34.5 | 18 | 16 | 34 | 10 | 1/4 | 8431 0603 63 |
| LTV38 R50-13 | M10 | 1/2 | 25-50 | 18-36 | 330 | 2.2 | 4.8 | 453 | 41 | 20 | 16 | 34 | 10 | 1/4 | 8431 0603 71 |
| LTV38 R57-13 | M10 | 1/2 | 30-57 | 22-41 | 280 | 2.2 | 4.8 | 453 | 41 | 20 | 16 | 34 | 10 | 1/4 | 8431 0603 51 |
| LTV38 R70-13 | M10 | 1/2 | 34-70 | 24-50 | 225 | 2.4 | 5.3 | 487 | 41 | 20 | 16 | 34 | 10 | 1/4 | 8431 0603 46 |
| LTV38 R85-13 | M10-12 | 1/2 | 40-85 | 29-61 | 190 | 2.8 | 6.1 | 530 | 52 | 25 | 16 | 34 | 10 | 1/4 | 8431 0603 38 |
| LTV48 R120-L13 | M12 | 1/2 | 70-120 | 51-88 | 215 | 3.5 | 7.6 | 590 | 52 | 25 | 28 | 59 | 12.5 | 1/2 | 8431 0534 88 |
| LTV48 R150-L13 | M12 | 1/2 | 70-150 | 51-111 | 170 | 3.5 | 7.6 | 590 | 52 | 25 | 28 | 59 | 12.5 | 1/2 | 8431 0534 93 |
| LTV48 R200-L13 | M14 | 1/2 | 115-200 | 85-148 | 100 | 3.8 | 8.3 | 610 | 52 | 25 | 28 | 59 | 12.5 | 1/2 | 8431 0534 98 |
| Flush socket | | | | | | | | | | | | | | | |
| LTV48 R150 FS | M12 | – | 70-150 | 44-111 | 180 | 3.5 | 7.6 | 590 | 70 | 25 | 28 | 59 | 12.7 | 1/2 | 8431 0610 17 |
| LTV48 R200 FS | M14 | – | 115-200 | 85-148 | 100 | 3.8 | 8.3 | 610 | 70 | 25 | 28 | 59 | 12.8 | 1/2 | 8431 0610 21 |

^a Female hex drive.

^b Quick change chuck.

LTV69 SERIES

- New twin motor – higher rundown speed, accurate tightening.
- High torques.
- Good access in cramped spaces.
- Spiral cut angle gears



| Model | Bolt size mm | Square drive in | Min torque at 3 bar soft joint | | Min torque at 6.3 bar soft joint | | Max torque at 6.3 bar soft joint | | Free speed r/min | Weight | | Length mm | Angle head height mm | Angle head center to side mm | Air consumption at free speed | | Rec. hose size mm | Air inlet thread in | Ordering No. |
|----------------------------|-----------------|--------------------|--------------------------------------|-------|--|-------|--|-------|---------------------|--------|------|--------------|-------------------------|---------------------------------|-------------------------------|-----|----------------------|------------------------|--------------|
| | | | Nm | ft lb | Nm | ft lb | Nm | ft lb | | kg | lb | | | | l/s | cfm | | | |
| Reversible | | | | | | | | | | | | | | | | | | | |
| LTV69 R180-13 ^a | M16 | 1/2 | 70 | 52 | 100 | 74 | 170 | 125 | 840 | 5.1 | 11.1 | 592 | 50 | 25.3 | 20 | 42 | 13 | 1/2 | 8431 0830 04 |
| LTV69 R370-20 ^a | M18 | 3/4 | 140 | 103 | 190 | 140 | 370 | 273 | 480 | 7.6 | 16.6 | 634 | 62 | 32.9 | 20 | 42 | 13 | 1/2 | 8431 0830 15 |
| LTV69 R600-25 ^a | M22 | 1 | 230 | 170 | 400 | 295 | 600 | 443 | 280 | 10.2 | 22.6 | 676 | 77 | 54.0 | 20 | 42 | 13 | 1/2 | 8431 0830 21 |
| Non-reversible | | | | | | | | | | | | | | | | | | | |
| LTV69 N180-13 | M16 | 1/2 | 70 | 52 | 100 | 74 | 170 | 125 | 840 | 4.6 | 10.1 | 577 | 50 | 25.3 | 20 | 42 | 13 | 1/2 | 8431 0830 35 |
| LTV69 N370-20 | M18 | 3/4 | 140 | 103 | 190 | 140 | 370 | 273 | 480 | 7.1 | 15.6 | 619 | 62 | 32.9 | 20 | 42 | 13 | 1/2 | 8431 0830 46 |
| LTV69 N600-25 | M22 | 1 | 230 | 170 | 400 | 295 | 600 | 443 | 280 | 9.7 | 21.3 | 661 | 77 | 54.0 | 20 | 42 | 13 | 1/2 | 8431 0830 52 |

^a Fixed reverse.

IN-LINE CROWFOOT TOOLS

Dimensions

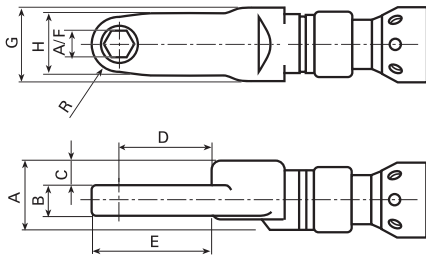

LTC

| Model | Torque | | Speed r/min | Weight | | Length mm | A/F mm | A mm | B mm | C mm | D mm | E mm | G mm | H mm | R mm | Ordering No. |
|-------------------|---------|-------|----------------|--------|------|--------------|-----------|---------|---------|---------|---------|---------|---------|---------|---------|--------------|
| | Nm | ft lb | | kg | lb | | | | | | | | | | | |
| LTC009 R08-10-LI3 | 4-8 | 2.9-6 | 210 | 1.3 | 2.9 | 312 | 10 | 34 | 10 | 13.5 | 37 | 41 | 35 | 22 | 10 | 8431 0613 72 |
| LTC009 R13-10-LI3 | 6-13 | 4-9 | 127 | 1.8 | 4 | 312 | 10 | 34 | 15 | 12.5 | 46.7 | 59.2 | 35 | 22 | 10 | 8431 0616 01 |
| LTC009 R14-12-LI3 | 6-14 | 4-10 | 127 | 1.8 | 4 | 319 | 12 | 34 | 15 | 12.5 | 45.5 | 71 | 35 | 30 | 13 | 8431 0616 07 |
| LTC28 R18-10-LI3 | 10-18 | 7-13 | 386 | 1.8 | 4 | 421 | 10 | 34 | 15 | 12.5 | 36.7 | 59.2 | 35 | 22 | 10 | 8431 0616 02 |
| LTC38 R28-12-LI3 | 14-28 | 10-20 | 470 | 1.8 | 4 | 493 | 12 | 34 | 15 | 12.5 | 45.5 | 71 | 35 | 30 | 13 | 8431 0616 09 |
| LTC38 R34-21-LI3 | 16-34 | 12-25 | 390 | 3.7 | 8.2 | 578 | 21 | 46 | 20 | 16 | 74.5 | 44 | 64 | 40 | 20 | 8431 0616 10 |
| LTC48 R80-21-LI3 | 50-80 | 37-59 | 250 | 4 | 8.9 | 578 | 21 | 46 | 20 | 16 | 74.5 | 84 | 64 | 40 | 20 | 8431 0616 12 |
| LTC48 R135-22-LI3 | 105-135 | 77-99 | 90 | 4.6 | 10.2 | 651 | 22 | 46 | 33 | 14 | 77.5 | 84 | 64 | 40 | 20 | 8431 0616 15 |

OFFSET CROWFOOT TOOLS

Dimensions

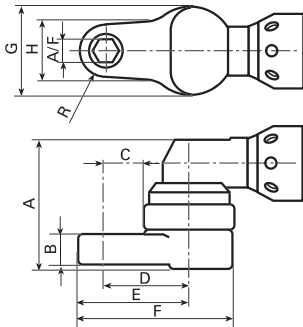

LTC

| Model | Torque | | Speed r/min | Weight | | Length mm | A/F mm | A mm | B mm | C mm | D mm | E mm | F mm | G mm | H mm | R mm | Ordering No. |
|-------------------------------------|--------|---------|----------------|--------|------|--------------|-----------|---------|---------|---------|---------|---------|---------|---------|---------|---------|--------------|
| | Nm | ft lb | | kg | lb | | | | | | | | | | | | |
| LTC009 R07-10-LO3 | 3-7 | 2.2-5 | 250 | 1.6 | 3.6 | 304 | 10 | 59.5 | 10 | 14.55 | 32.8 | 42.8 | 61.1 | 36.5 | 22 | 10 | 8431 0614 94 |
| LTC29-2R19-10-LO3 | 10-19 | 7.3-14 | 640 | 2 | 4.4 | 384 | 10 | 60.3 | 15 | 14.55 | 32.8 | 42.8 | 61.1 | 36.5 | 22 | 10 | 8431 0615 02 |
| LTC29-2R21-13-LO5 | 11-21 | 8-15 | 500 | 2 | 4.4 | 457 | 13 | 58.5 | 10 | 71.6 | 93.6 | 108.1 | 130.1 | 44 | 31 | 14.5 | 8431 0615 04 |
| LTC39-2R28-12-LO5 | 17-28 | 13-21 | 560 | 2.5 | 5.6 | 488 | 12 | 69.5 | 15 | 62 | 84 | 97 | 119 | 44 | 30 | 13 | 8431 0615 08 |
| LTC39-2R40-14-LO3 | 22-40 | 16-29 | 460 | 2.4 | 5.3 | 452 | 14 | 77.8 | 18 | 24.8 | 46.8 | 61.3 | 83.3 | 44 | 31 | 14.5 | 8431 0615 11 |
| LTC39-2R60-16-LO3 | 34-60 | 25-44 | 305 | 3 | 6.7 | 541 | 16 | 91 | 24 | 27 | 51 | 66 | 91.5 | 48 | 30 | 15 | 8431 0615 14 |
| LTC48 R80-17-LO3 | 56-80 | 41-59 | 215 | 4 | 8.9 | 641 | 17 | 69.5 | 27 | 30.3 | 55.8 | 72.3 | 97.8 | 48 | 33 | 16.5 | 8431 0615 17 |
| LTC48 R96-18-LO3 | 56-96 | 41-71 | 210 | 4.7 | 10.4 | 651 | 18 | 99 | 32 | 32 | 63.2 | 82.2 | 113.5 | 62.5 | 38 | 19 | 8431 0615 21 |
| Extra heavy duty attachments | | | | | | | | | | | | | | | | | |
| LTC38 R33-13-A-O-3 | 16-33 | 11.8-24 | 430 | 2.6 | 5.8 | 487 | 13 | 60 | 19 | 32.8 | 52.8 | 68.8 | 88.8 | 40 | 34 | 16 | 8431 0611 01 |
| LTC48 R56-17-A-O-3 | 24-56 | 18-41 | 400 | 3.9 | 8.7 | 619 | 17 | 66 | 19 | 45.1 | 67.6 | 87.2 | 109.7 | 45 | 39.2 | 19.5 | 8431 0611 06 |
| LTC38 R40-17-A-O-3 | 23-40 | 17-29 | 360 | 3 | 6.7 | 519 | 17 | 66 | 19 | 45.1 | 67.6 | 87.2 | 109.7 | 45 | 39.2 | 19.5 | 8431 0611 08 |
| LTC48 R120-19-A-O-3 | 48-120 | 36-89 | 180 | 4.3 | 9.6 | 656 | 19 | 87 | 25 | 42.3 | 67.6 | 87.4 | 112.7 | 54 | 39.5 | 19.75 | 8431 0611 15 |

IN-LINE TUBE NUT TOOLS

Dimensions

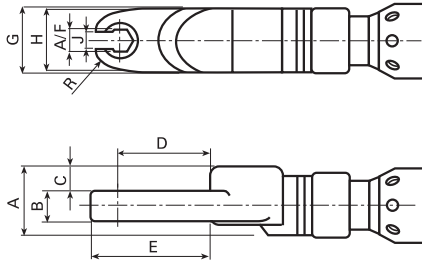

LTO

| Model | Torque | | Speed r/min | Weight | | Length mm | A/F mm | A mm | B mm | C mm | D mm | E mm | G mm | H mm | J mm | R mm | Ordering No. |
|------------------|--------|-------|----------------|--------|-----|--------------|-----------|---------|---------|---------|---------|---------|---------|---------|---------|---------|--------------|
| | Nm | ft lb | | kg | lb | | | | | | | | | | | | |
| LTO28 R06-8-LI3 | 2.1-6 | 1.5-4 | 833 | 1.8 | 4 | 369 | 8 | 32 | 10 | 13 | 27.3 | 25.4 | 33.5 | 31 | 7 | 9.8 | 8431 0617 02 |
| LTO28 R12-8-LI3 | 6-12 | 4-8 | 420 | 2 | 4.4 | 388 | 8 | 32 | 10 | 13 | 27.3 | 25.4 | 33.5 | 31 | 7 | 9.8 | 8431 0617 03 |
| LTO28 R12-10-LI3 | 6-12 | 4-8 | 420 | 2 | 4.4 | 396 | 10 | 32 | 10 | 13 | 27.3 | 25.4 | 33.5 | 31 | 7 | 9.8 | 8431 0612 44 |
| LTO28 R15-10-LI3 | 6-15 | 4-11 | 400 | 2 | 4.4 | 397 | 10 | 32 | 12 | 11 | 27.9 | 26.1 | 33.5 | 32 | 8 | 10.3 | 8431 0612 46 |
| LTO28 R17-13-LI3 | 8-17 | 6-13 | 350 | 1.9 | 4.2 | 415 | 13 | 34 | 11 | 14.5 | 36.3 | 32.3 | 35 | 38 | 8.5 | 12.4 | 8431 0612 48 |
| LTO28 R19-10-LI3 | 8-19 | 6-14 | 350 | 1.9 | 4.2 | 402 | 10 | 34 | 14 | 13 | 31.9 | 29.7 | 35 | 38 | 8 | 11.2 | 8431 0617 07 |
| LTO38 R26-13-LI3 | 14-35 | 10-25 | 220 | 3 | 6.7 | 536 | 13 | 46 | 11 | 20.8 | 52 | 47.3 | 45 | 55 | 12.5 | 17.2 | 8431 0612 50 |
| LTO38 R26-17-LI3 | 15-43 | 11-31 | 200 | 3.2 | 7.1 | 547 | 17 | 46 | 12 | 20 | 60.3 | 38.8 | 45 | 59 | 16 | 20.1 | 8431 0612 54 |
| LTO38 R28-12-LI3 | 10-28 | 7-20 | 320 | 2.9 | 6.4 | 514 | 12 | 43 | 11 | 17.5 | 43.7 | 29.3 | 40 | 50 | 10.4 | 15 | 8431 0617 08 |
| LTO38 R35-12-LI3 | 14-35 | 10-25 | 220 | 2.9 | 6.4 | 519 | 12 | 43 | 11 | 17.5 | 43.7 | 29.3 | 40 | 50 | 10.4 | 15 | 8431 0617 09 |
| LTO38 R43-14-LI3 | 14-43 | 10-31 | 220 | 3.2 | 7.1 | 522 | 14 | 46 | 18 | 17 | 41 | 38.5 | 45 | 50 | 12 | 15 | 8431 0617 10 |

OFFSET TUBE NUT TOOLS

Dimensions

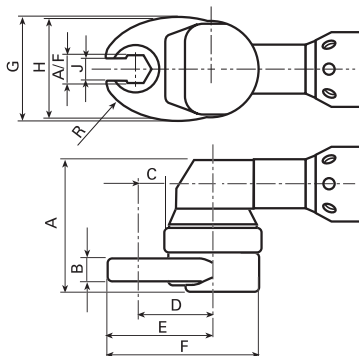

LTO

| Model | Torque | | Speed r/min | Weight | | Length mm | A/F mm | A mm | B mm | C mm | D mm | E mm | F mm | G mm | J mm | R mm | Ordering No. |
|------------------|--------|--------|----------------|--------|-----|--------------|-----------|---------|---------|---------|---------|---------|---------|---------|---------|---------|--------------|
| | Nm | ft lb | | kg | lb | | | | | | | | | | | | |
| LTO28 R12-12-LO5 | 6-12 | 4.4-9 | 470 | 2 | 4.4 | 402 | 12 | 66.5 | 11 | 51 | 73 | 84.9 | 106.9 | 44 | 8 | 11.9 | 8431 0618 05 |
| LTO38 R28-13-LO5 | 11-28 | 8.0-20 | 250 | 2.3 | 5.1 | 506 | 13 | 71 | 18 | 53.3 | 75.3 | 87.7 | 109.7 | 44 | 10.4 | 12.4 | 8431 0618 12 |

HOLD AND DRIVE

Hold and drive bolts are being used increasingly by, for example, truck manufacturers on the frame assembly line, making what used to be a two-man operation, a one-man task. The distinguishing feature of a hold and drive bolt is that one part is held and the other is tightened from the same side.

LTV HAD

- Especially suitable for shock absorber assembly.
- Special tools based on the standard LTV series are available for use on hold and drive bolts.
- HAD sockets are available in three different lengths.
- Special sockets available upon request.
- Also suitable for break-away bolts, Hi Lok/Hi Shear.



LTV48 R200 HAD

NOTE: To reduce the reaction force in the holder, the use of a reaction bar is recommended.

| Model | Bolt size mm | Torque range soft joint ^a | | Free speed r/min | Weight | | Length mm | Angle head height mm | Angle head center to side mm | Air consumption at free speed | | Rec. hose size mm | Air inlet thread in | Ordering No. |
|-------------------------------|--------------|--------------------------------------|---------|------------------|--------|------|-----------|----------------------|------------------------------|-------------------------------|-----|-------------------|---------------------|--------------|
| | | Nm | ft lb | | kg | lb | | | | l/s | cfm | | | |
| LTV38 R40 LT HAD ^b | M8-10 | 15-40 | 11-30 | 210 | 3.0 | 6.5 | 530 | 75 | 26 | 10 | 16 | 10 | 1/4 | 8431 0609 52 |
| LTV38 R42 HAD | M8 | 20-42 | 15-31 | 430 | 2.2 | 4.8 | 453 | 62 | 18.5 | 10 | 16 | 10 | 1/4 | 8431 0603 75 |
| LTV38 R50 HAD | M10 | 25-50 | 18-36 | 360 | 2.2 | 4.8 | 453 | 62 | 18.5 | 10 | 16 | 10 | 1/4 | 8431 0603 82 |
| LTV38 R85 HAD | M10-12 | 40-85 | 30-67 | 210 | 3.0 | 6.5 | 530 | 75 | 26 | 10 | 16 | 10 | 1/4 | 8431 0609 58 |
| LTV48 R120 HAD | M12-14 | 70-120 | 52-89 | 220 | 3.3 | 7.3 | 590 | 75 | 26 | 28 | 59 | 12.5 | 1/2 | 8431 0610 26 |
| LTV48 R150 HAD | M14 | 70-150 | 52-111 | 180 | 3.3 | 7.3 | 590 | 75 | 26 | 28 | 59 | 12.5 | 1/2 | 8431 0610 30 |
| LTV48 R200 HAD | M14 | 115-200 | 85-150 | 100 | 3.3 | 7.3 | 610 | 75 | 28 | 28 | 59 | 12.5 | 1/2 | 8431 0610 32 |
| LTV69 R370 HAD | M18 | 190-370 | 140-273 | 480 | 7.6 | 16.6 | 634 | 104 | 33 | 20 | 42 | 12.5 | 1/2 | 8431 0831 65 |

^a At min 5 bar.

^b For low torque applications.

NOTE: For sockets and holders see accessory pages.

Other types of Hold and Drive equipped tools are available on special request.

STALL TYPE

- Low inertia design gives accurate torque independent of joint stiffness – in other words, low mean shift.
- Easy torque setting by adjusting the inlet air pressure.
- Reliable, well-proven design.
- Good accessibility due to small dimensioned angle head.



| Model | Bolt size mm | Square drive in | Torque range soft joint | | | | Free speed r/min | Weight | | Length mm | Angle head center | | Air consumption at free speed | | Rec. hose size mm | Air inlet thread in | Ordering No. |
|-----------------------|--------------|-----------------|-------------------------|----|----------|---|------------------|--------|-----|-----------|-------------------|------------|-------------------------------|-----|-------------------|---------------------|--------------|
| | | | at 6.3 bar | | at 3 bar | | | kg | lb | | height mm | to side mm | l/s | cfm | | | |
| Reversible | | | | | | | | | | | | | | | | | |
| LMV28 R11-10 | M6 | 3/8 | 11 | 8 | 5 | 4 | 1200 | 1.1 | 2.4 | 264 | 28 | 11 | 10 | 21 | 10 | 1/4 | 8431 0591 07 |
| LMV28 R14-10 | M6 | 3/8 | 14 | 10 | 7 | 5 | 1000 | 1.1 | 2.4 | 264 | 29.5 | 13.5 | 10 | 21 | 10 | 1/4 | 8431 0591 09 |
| Non reversible | | | | | | | | | | | | | | | | | |
| LMV28 N16-10 | M6 | 3/8 | 16 | 12 | 8 | 6 | 1000 | 1.0 | 2.2 | 239 | 29.5 | 13.5 | 11 | 23 | 10 | 1/4 | 8431 0590 17 |

RATCHET WRENCHES

- Unique accessibility, the ratchet wrench is a superior tool for limited space applications.
- To loosen, turn the tool upside down.



| Model | Bolt size mm | Square drive in | Torque range soft joint | | | | Free speed r/min | Weight | | Length mm | Angle head center | | Air consumption at free speed | | Rec. hose size mm | Air inlet thread in | Ordering No. |
|------------------|--------------|-----------------|-------------------------|----|----------|----|------------------|--------|-----|-----------|-------------------|------------|-------------------------------|-----|-------------------|---------------------|--------------|
| | | | at 6.3 bar | | at 3 bar | | | kg | lb | | height mm | to side mm | l/s | cfm | | | |
| LBR33 S26/114-13 | M8 | 13 ^a | 22 | 16 | 11 | 8 | 185 | 1.4 | 3.1 | 290 | 15 | 13 | 9.5 | 20 | 10 | 1/4 | 8431 0345 71 |
| LBR33 S26/118-16 | M8-10 | 16 ^a | 30 | 22 | 15 | 11 | 135 | 1.4 | 3.1 | 300 | 15 | 18 | 9.5 | 20 | 10 | 1/4 | 8431 0346 70 |
| LBR33 S26/118-17 | M8-10 | 17 ^a | 30 | 22 | 15 | 11 | 135 | 1.4 | 3.1 | 300 | 15 | 18 | 9.5 | 20 | 10 | 1/4 | 8431 0346 62 |

^aFemale hex drive.

WORM-DRIVE NUTRUNNERS

- Teasing throttle characteristics give significantly reduced free speed.
- Suitable for:
 - Nutrunning
 - Light reaming
 - Tapping
 - Tube-rolling
- Can also be incorporated in rigs as air motors for intermittent operation.



| Model | Bolt size mm | Square drive in | Torque range soft joint | | | | Free speed r/min | Weight | | Length mm | Angle head center | | Air consumption at free speed | | Rec. hose size mm | Air inlet thread in | Ordering No. |
|------------|--------------|-------------------|-------------------------|----|----------|----|------------------|--------|-----|-----------|-------------------|------------|-------------------------------|-----|-------------------|---------------------|--------------|
| | | | at 6.3 bar | | at 3 bar | | | kg | lb | | height mm | to side mm | l/s | cfm | | | |
| LMK33 S001 | M10-12 | 7/16 ^a | 55 | 41 | 27 | 20 | 130 | 2.2 | 4.9 | 385 | 39 | 41 | 9.5 | 20 | 10 | 1/4 | 8431 0343 08 |
| LMK33 S002 | M10-12 | 7/16 ^a | 32 | 24 | 16 | 12 | 235 | 1.9 | 4.2 | 291 | 39 | 41 | 9.5 | 20 | 10 | 1/4 | 8431 0343 16 |
| LMK33 S005 | M10 | 7/16 ^a | 29 | 21 | 14 | 10 | 480 | 1.7 | 3.7 | 263 | 39 | 41 | 9.5 | 20 | 10 | 1/4 | 8431 0343 24 |

^aFemale hex drive.

Accessories Included

FOR LTV MODELS

Clutch adjustment key

FOR LBR, LMV AND LMK MODELS

Socket adapter, 3/8" square drive LMK22,
1/2" square drive LMK33

Optional Accessories

EXTENSIONS FOR LTV

| Suitable for tool | Length of extension – "L" | | Ordering No. |
|----------------------|---------------------------|----|--------------|
| | mm | in | |
| LTV28 | 75 | 3 | 4210 3491 93 |
| LTV28 | 150 | 6 | 4210 3491 95 |
| LTV38 (not R70/R85) | 75 | 3 | 4210 4301 80 |
| LTV38 (not R70/R85) | 150 | 6 | 4210 4302 80 |
| LTV38 R70/R85/LTV48 | 75 | 3 | 4210 4303 80 |
| LTV38 R70/R85/LTV48 | 150 | 6 | 4210 4304 80 |
| LTV39-2 R48-10 | 75 | 3 | 4210 4472 81 |
| LTV39-2 R48-10 | 150 | 6 | 4210 4472 83 |
| LTV39-2 R48/56/70-13 | 75 | 3 | 4210 4472 80 |
| LTV39-2 R48/56/70-13 | 150 | 6 | 4210 4473 80 |
| LTV39-2 R56-10 | 75 | 3 | 4210 4472 82 |
| LTV39-2 R56-10 | 150 | 6 | 4210 4472 84 |
| LTV39-2 R85 | 75 | 3 | 4210 4474 80 |
| LTV39-2 R85 | 150 | 6 | 4210 4475 80 |

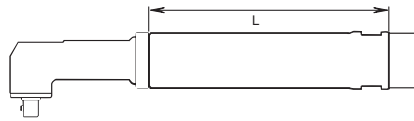

Reaction bar kit



Protective cover (a)



Protective cover (b)



Signal connection kit (RE)

FOR LTV AND LTC MODELS

| Model | Exhaust hose | Suspension yoke | | Protective cover (see picture) | Reaction bar kit | Signal connection kit (-RE) |
|--|--------------|-----------------|--------------|-------------------------------------|------------------|-----------------------------|
| | | Fixed | Swivelling | | | |
| LTV28 R07 | 4210 2053 00 | 4210 1631 82 | 4210 3931 80 | 4210 3990 00 ^a | | 4210 4019 90 |
| LTV28, all models except R07 | 4210 2053 00 | 4210 1631 82 | 4210 3931 80 | 4210 3990 00 ^a | | 4210 4018 90 |
| LTV29-2/39-2 | 4210 2053 00 | 4210 1631 82 | 4210 4408 80 | | | 4210 4017 90 |
| LTV29-2/39-2 R12/R16 | | | | 4220 2744 05 ^b | | |
| LTV29-2/39-2 R24/R30 | | | | 4220 2744 03 ^b | | |
| LTV38 R42/R50/R57 | 4210 2053 00 | 4210 1631 82 | 4210 3931 81 | 4210 3992 90 ^a (not LTC) | | 4210 4017 90 |
| LTC38, LTV38 FS | | | | | | |
| LTV38 R70 | 4210 2053 00 | 4210 1631 82 | 4210 3931 81 | 4210 4003 90 ^a | | 4210 4017 90 |
| LTV38 R85, LTV38 HAD | 4210 2053 00 | 4210 1631 82 | 4210 3931 81 | 4210 4004 90 ^a | 4210 4020 80 | 4210 4017 90 |
| LTV39-2 R48-10/R50-10 | | | | 4220 2744 02 ^b | | |
| LTV39-2 R48-13/R50-13/R70 | | | | 4220 2744 04 ^b | | |
| LTV48 R65 | 4210 4011 00 | | 4210 4021 80 | 4210 4058 90 ^a | 4210 4020 80 | 4210 4057 90 |
| LTV48 R120/R150/R200, LTC48, LTV48 FS, LTV48 HAD | 4210 4011 00 | | 4210 4021 80 | 4210 4059 90 ^a | 4210 4020 80 | 4210 4057 90 |
| LTV69 N/R180 | 4210 4011 00 | | 4210 3088 87 | 4210 4059 90 ^a | 4220 1128 80 | |
| LTV69 N/R370 | 4210 4011 00 | | 4210 3088 87 | | 4220 1201 80 | |
| LTV69 N/R600 | 4210 4011 00 | | 4210 3088 87 | | 4220 1746 80 | |

Optional Accessories for Flush socket tools

INTEGRATED SOCKETS

| Model | Hexagon socket size AF mm / in | Socket extension mm | Ordering No. | |
|--|--|------------------------|--------------|--------------|
| LTV29-2 R24/R30 FS and ETV ST61-30-FS | 8 | 1.5 | 4220 4188 88 | |
| | 10 | 1.5 | 4220 4188 90 | |
| | 12 | 1.5 | 4220 4188 92 | |
| | 13 | 1.5 | 4220 4188 93 | |
| | 5/16" | 1.5 | 4220 4188 98 | |
| | 1/4" | 1.5 | 4220 4188 96 | |
| LTV39-2 R37/R48/R56 FS and ETV ST61-40-FS, ETV ST61-50-FS | 10 | 2.5 | 4220 3987 90 | |
| | 12 | 2.5 | 4220 3987 92 | |
| | 13 | 2.5 | 4220 3987 93 | |
| | 14 | 2.5 | 4220 3987 94 | |
| | 15 | 2.5 | 4220 3987 95 | |
| | 16 | 2.5 | 4220 3987 96 | |
| | 17 | 2.5 | 4220 3987 97 | |
| | 18 | 2.5 | 4220 3987 98 | |
| | 9/16" | 2.5 | 4220 3987 99 | |
| | 13 | 7 | 4220 4012 93 | |
| | 13 | 15 | 4220 4013 93 | |
| | 14 | 15 | 4220 4013 94 | |
| | LTV39-2 R70 FS and ETV ST61-70-FS | 16 | 0.5 | 4220 1251 00 |
| 15 | | 16.5 | 4220 1621 00 | |
| 15 | | 1.5 | 4220 1621 01 | |
| 18 | | 6.5 | 4220 1621 02 | |
| 16 | | 11.5 | 4220 1621 03 | |
| 10 | | 3.5 | 4220 1621 04 | |
| 20 | | 8.5 | 4220 1621 05 | |
| 17.5 | | 6.5 | 4220 1621 06 | |
| 19 | | 8.5 | 4220 1621 07 | |
| 16 | | 16.5 | 4220 1621 08 | |
| 18 | | 10.5 | 4220 1621 09 | |
| 16 | | 14.5 | 4220 1621 10 | |
| 19 | | 10 | 4220 1621 11 | |
| 17 | | 11.5 | 4220 1621 12 | |
| 13 | | 3.5 | 4210 2749 01 | |
| 15 | | 3.5 | 4210 2749 02 | |
| 12 | | 3.5 | 4210 2749 03 | |
| 14 | | 3.5 | 4210 2749 04 | |
| 9/16" | | 3.5 | 4210 2749 05 | |
| 7/16" | | 3.5 | 4210 2749 06 | |
| LTV39-2 R85/R120 FS, LTV48 R150/R200 FS, and ETV DS72-160FS/200FS , ETV ST61 100/150/180/200 FS | | 24 | 12.5 | 4220 1595 01 |
| | | 18 | 4.5 | 4220 1595 02 |
| | | 25.4 | 13.5 | 4220 1595 03 |
| | 18 | 14.5 | 4220 1595 04 | |
| | 21 | 13.5 | 4220 1595 05 | |
| | 21 | 24 | 4220 1595 06 | |
| | 14 | 5.5 | 4220 1595 07 | |
| | 14.3 | 9 | 4220 1595 08 | |
| | 17.5 | 7.5 | 4220 1595 09 | |
| | 18 | 2 | 4210 3534 68 | |
| | 18 | 8.5 | 4210 3534 18 | |
| | 19 | 9.5 | 4210 3534 19 | |
| | 21 | 10.5 | 4210 3534 21 | |
| | 22 | 10.5 | 4210 3534 22 | |
| | 24 | 10.5 | 4210 3534 24 | |
| | 27 | 13.8 | 4210 3534 27 | |

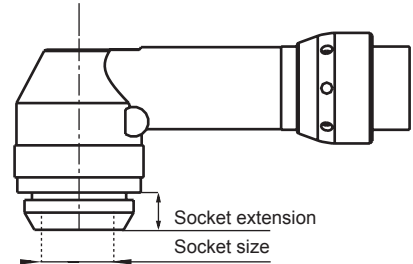

Optional Accessories for Crowfoot tools

HEX SOCKETS

| Width across flats | | Ordering No. |
|---|------|--------------|
| mm | in | |
| For LTC38 R33/N41-13-A-O-3^a | | |
| | 7/16 | 4210 2625 03 |
| 12 | | 4210 2625 04 |
| | 1/2 | 4210 2625 01 |
| 13 | | 4210 2625 00 |
| 14 | | 4210 2625 02 |
| 15 | | 4210 2625 06 |
| For LTC38 R40/N48-17-A-O-3^b, LTC48 R56-17-A-O-3^b | | |
| 13 | | 4210 2626 06 |
| 14 | | 4210 2626 04 |
| 15 | | 4210 2626 03 |
| | 1/2 | 4210 2626 05 |
| | 5/8 | 4210 2626 02 |
| 16 | | 4210 2626 00 |
| 17 | | 4210 2626 01 |
| 18 | | 4210 2626 10 |
| 19 | | 4210 2626 08 |
| For LTC48 R96/R120-19-A-O-3^c | | |
| 13 | | 4210 2624 06 |
| 14 | | 4210 2624 05 |
| 15 | | 4210 2624 04 |
| 16 | | 4210 2624 03 |
| 17 | | 4210 2624 02 |
| 18 | | 4210 2624 01 |
| 19 | 3/4 | 4210 2624 00 |

| Model | H mm | B mm | C mm |
|---------------------|---------|---------|---------|
| LTC38 R33-13-A-O-3 | 19 | 32 | 16 |
| LTC38 R40-17-A-O-3 | 19 | 39 | 20 |
| LTC48 R56-17-A-O-3 | 19 | 39 | 20 |
| LTC48 R96-19-A-O-3 | 25 | 39 | 20 |
| LTC48 R120-19-A-O-3 | 25 | 39 | 20 |
| LTC38 N41-13-A-O-3 | 19 | 32 | 16 |

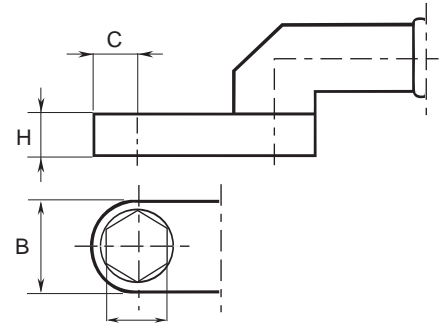

^a 13 mm socket mounted on tool.

^b 17 mm socket mounted on tool.

^c 19 mm socket mounted on tool.

Optional Accessories for Open End Type

SOCKETS

| A Socket size mm | B Open end mm | Ordering No. |
|---------------------------|---------------------|--------------|
| LTO28 R12-10-L-I-3 | | |
| 5/16" | 7 | 4210 4288 54 |
| 8 mm | 7 | 4210 4288 55 |
| 3/8" | 7 | 4210 4288 53 |
| 9 mm | 7 | 4210 4288 52 |
| 10 mm | 7 | 4210 4288 51 |
| LTO28 R15-10-L-I-3 | | |
| 8 mm | 8 | 4210 4289 56 |
| 9 mm | 8 | 4210 4289 55 |
| 3/8" | 8 | 4210 4289 54 |
| 10 mm | 8 | 4210 4289 51 |
| 11 mm | 8 | 4210 4289 57 |
| 7/16" | 8 | 4210 4289 58 |
| 12 mm | 8 | 4210 4289 53 |
| LTO28 R17-13-L-I-3 | | |
| 3/8" | 8.5 | 4210 4290 52 |
| 10 mm | 8.5 | 4210 4290 53 |
| 11 mm | 8.5 | 4210 4290 59 |
| 7/16" | 8.5 | 4210 4290 54 |
| 12 mm | 8.5 | 4210 4290 57 |
| 1/2" | 8.5 | 4210 4290 55 |
| 13 mm | 8.5 | 4210 4290 51 |
| 14 mm | 8.5 | 4210 4290 58 |
| 9/16" | 8.5 | 4210 4290 56 |

| A Socket size mm | B Open end mm | Ordering No. |
|---------------------------|---------------------|--------------|
| LTO38 R26-13-L-I-3 | | |
| 11 mm | 12.5 | 4210 4291 63 |
| 13 mm | 12.5 | 4210 4291 51 |
| 14 mm | 12.5 | 4210 4291 58 |
| 9/16" | 12.5 | 4210 4291 53 |
| 15 mm | 12.5 | 4210 4291 55 |
| 5/8" | 12.5 | 4210 4291 54 |
| 16 mm | 12.5 | 4210 4291 52 |
| 17 mm | 12.5 | 4210 4291 60 |
| 11/16" | 12.5 | 4210 4291 56 |
| 18 mm | 12.5 | 4210 4291 61 |
| 19 mm | 12.5 | 4210 4291 62 |
| 3/4" | 12.5 | 4210 4291 57 |
| LTO38 R26-17-L-I-3 | | |
| 14 mm | 14 | 4210 4292 55 |
| 5/8" | 14.6 | 4210 4292 54 |
| 17 mm | 16 | 4210 4292 51 |
| 18 mm | 16 | 4210 4292 53 |
| 19 mm | 16 | 4210 4292 57 |
| 3/4" | 16 | 4210 4292 52 |
| 20 mm | 16 | 4210 4292 61 |
| 13/16" | 16 | 4210 4292 63 |
| 21 mm | 16 | 4210 4292 62 |
| 22 mm | 16 | 4210 4292 56 |
| 7/8" | 16 | 4210 4292 58 |
| 15/16" | 16 | 4210 4292 60 |
| 24 mm | 17.2 | 4210 4292 59 |

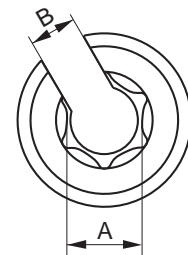

Optional Accessories for Stall type

FEMALE HEX SOCKETS

| Dimensions in | Ordering No. LBR33 S26/114 | Ordering No. LBR33 S26/118 | Dimensions in | Ordering No. LBR33 S26/114 | Ordering No. LBR33 S26/118 |
|---------------|----------------------------|----------------------------|---------------|----------------------------|----------------------------|
| 1/4 | 4210 0360 05 | – | 10 | 4210 0414 10 | – |
| 5/16 | 4210 0360 02 | – | 12 | 4210 0414 12 | 4210 0418 12 |
| 3/8 | 4210 0360 03 | 4210 0389 02 | 13 | 4210 0414 13 | 4210 0418 13 |
| 7/16 | 4210 0360 04 | 4210 0389 03 | 14 | 4210 0414 14 | 4210 0418 14 |
| 1/2 | 4210 0360 01 | 4210 0389 04 | 15 | 4210 0414 15 | 4210 0418 15 |
| 9/16 | – | 4210 0389 06 | 16 | – | 4210 0418 16 |
| 5/8 | – | 4210 0389 01 | 17 | – | 4210 0418 17 |
| 3/4 | – | 4210 0389 05 | 18 | – | 4210 0418 18 |
| | | | 19 | – | 4210 0389 05 |

NOTE: That 1/2" female hex sockets must be used together with socket adapters.

SOCKET ADAPTERS

| Dimensions | Ordering No. LBR33 S26/114 | Ordering No. LBR33 S26/118 |
|----------------------------|----------------------------|----------------------------|
| 1/2" hex 3/8" square drive | 4090 0163 00 | 4090 0163 00 |
| 1/2" hex 1/2" square drive | 4090 0164 00 | 4090 0164 00 |

Optional Accessories for Hold and Drive tools

NUT SOCKET, SCREW HOLDER AND BIT HOLDER FOR LTV38 R42-HAD/LTV38 R50-HAD AND ETV ST61-28/50 HAD

Nut socket (Fig. 1)

| Width across flats W mm | Socket Ø D mm | A | Ordering No. B | C |
|-------------------------|---------------|--------------|----------------|--------------|
| 10 | 22 | 4220 1769 16 | 4220 1769 31 | 4220 1769 51 |
| 11 | 22 | 4220 1769 15 | 4220 1769 32 | 4220 1769 52 |
| 12 | 22 | 4220 1769 13 | 4220 1769 33 | 4220 1769 53 |
| 13 | 22 | 4220 1769 09 | 4220 1769 12 | 4220 1769 54 |
| 14 | 22 | 4220 1769 05 | 4220 1769 35 | 4220 1769 08 |
| 15 | 22 | 4220 1769 14 | 4220 1769 36 | 4220 1769 56 |
| 16 | 25 | 4220 1888 71 | 4220 1888 81 | 4220 1888 91 |
| 17 | 25 | 4220 1888 72 | 4220 1888 82 | 4220 1888 92 |
| 18 | 26 | 4220 1888 73 | 4220 1888 83 | 4220 1888 93 |
| 19 | 27 | 4220 1888 74 | 4220 1888 84 | 4220 1888 94 |
| 20 | 31 | 4220 1888 75 | 4220 1888 85 | 4220 1888 95 |
| 21 | 31 | 4220 1888 76 | 4220 1888 86 | 4220 1888 96 |

Measurements in mm

Figure 1

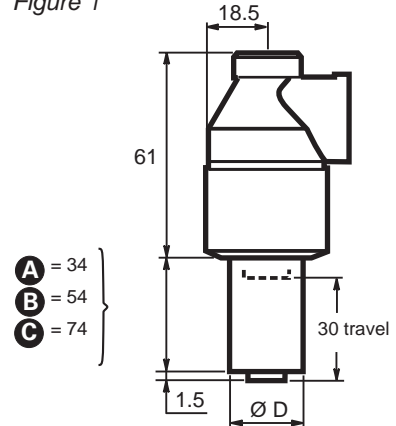

Screw holder

| Dimension X x Y mm | Suitable socket size mm | A | Ordering No. B | C |
|--------------------|-------------------------|--------------|----------------|--------------|
| 6.6 x 5 | 10-21 | 4220 1770 19 | – | – |
| 7 x 5 | 10-21 | – | 4220 1770 17 | – |
| 5.1 x 8.2 | 10-21 | 4220 1770 01 | – | 4220 1770 16 |
| 8 x 6 | 10-21 | 4220 1770 02 | – | – |

Two flats

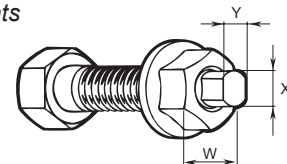

Bit holder

| Bit holder 1/4" | | | | |
|-----------------|--------------|--------------|-------------|------|
| A | B | C | Width N, mm | Bits |
| 4220 1959 01 | 4220 1959 04 | 4220 1959 03 | 10-21 | 1/4" |

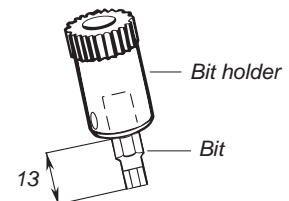

Optional Accessories for Hold and Drive tools

NUT SOCKET, SCREW HOLDER AND BIT HOLDER FOR LTV48 R100-HAD AND ETV ST61/81-100-HAD

Nut socket (Fig. 2)

| Width across flats W mm | Socket Ø D mm | Ordering No. | | |
|----------------------------|------------------|--------------|--------------|--------------|
| | | A | B | C |
| 13 | 21 | 4220 4477 13 | 4220 4477 33 | 4220 4477 53 |
| 14 | 22 | 4220 4477 14 | 4220 4477 34 | 4220 4477 54 |
| 15 | 23 | 4220 4477 15 | 4220 4477 35 | 4220 4477 55 |
| 16 | 24 | 4220 4477 16 | 4220 4477 36 | 4220 4477 56 |
| 17 | 27 | 4220 4477 17 | 4220 4477 37 | 4220 4477 57 |
| 18 | 27 | 4220 4477 18 | 4220 4477 38 | 4220 4477 58 |
| 19 | 29 | 4220 4477 19 | 4220 4477 39 | 4220 4477 59 |
| 21 | 30 | 4220 4477 21 | 4220 4477 41 | 4220 4477 61 |
| 22 | 32 | 4220 4477 22 | 4220 4477 42 | 4220 4477 62 |
| 24 | 34 | 4220 4477 24 | 4220 4477 44 | 4220 4477 64 |

Measurements in mm

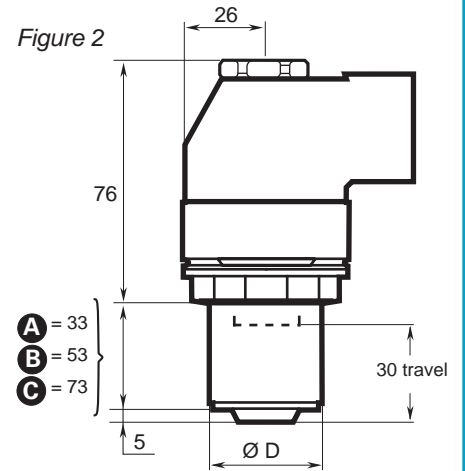

Screw holder – Two flats

| Dimension X x Y mm | Suitable socket size mm | Ordering No. | | |
|--------------------------|-------------------------------|--------------|--------------|--------------|
| | | A 33 mm | B 53 mm | C 73 mm |
| 7x5 | 13-24 | 4220 4524 05 | 4220 4524 15 | 4220 4524 25 |
| 8x6 | 13-24 | 4220 4524 06 | 4220 4524 16 | 4220 4524 26 |
| 8x6.3 | 13-24 | 4220 4524 07 | 4220 4524 17 | 4220 4524 27 |
| 9.55x7.6 | 14-24 | 4220 4524 08 | 4220 4524 18 | 4220 4524 28 |
| 11.20x8.9 | 16-24 | 4220 4524 09 | 4220 4524 19 | 4220 4524 29 |
| 13x9.8 | 16-24 | 4220 4524 10 | 4220 4524 20 | 4220 4524 30 |

Two flats

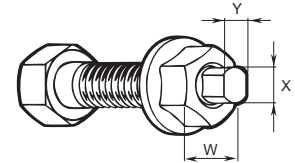

Screw holder – Male hexagon

| Dimension N mm | Suitable socket size mm | Ordering No. | | |
|-------------------|-------------------------------|--------------|--------------|--------------|
| | | A 33 mm | B 53 mm | C 73 mm |
| 5 | 13-24 | 4220 4478 15 | 4220 4478 25 | 4220 4478 45 |
| 6 | 13-24 | 4220 4478 16 | 4220 4478 26 | 4220 4478 46 |
| 7 | 13-24 | 4220 4478 07 | 4220 4478 27 | 4220 4478 47 |
| 8 | 13-24 | 4220 4478 08 | 4220 4478 28 | 4220 4478 48 |
| 9 | 14-24 | 4220 4478 09 | 4220 4478 29 | 4220 4478 49 |
| 10 | 16-24 | 4220 4478 10 | 4220 4478 30 | 4220 4478 50 |
| 11 | 16-24 | 4220 4478 11 | 4220 4478 31 | 4220 4478 51 |

Male hexagon

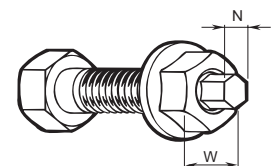

Bit holder – Female hexagon

| Suitable socket size mm | Ordering No. | | |
|-------------------------------|--------------|--------------|--------------|
| | A 33 mm | B 53 mm | C 73 mm |
| 13-24 | 4220 4524 60 | 4220 4524 61 | 4220 4524 62 |

Female hexagon

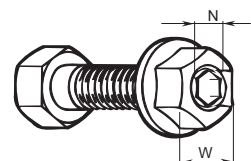

Optional Accessories for Hold and Drive tools

NUT SOCKET, SCREW HOLDER AND BIT HOLDER FOR LTV38 R40 LT/R 85 HAD, LTV48 HAD AND ETV ST61/81-100-HAD-HD/120/150/180/200 HAD

Nut socket (Fig. 3)

| Width across flats W mm | Socket Ø D mm | A | Ordering No. B | C |
|----------------------------|------------------|--------------|-------------------|--------------|
| 13 | 30 | 4210 3513 13 | 4210 3513 33 | 4210 3513 53 |
| 14 | 30 | 4210 3513 14 | 4210 3513 34 | 4210 3513 54 |
| 15 | 30 | 4210 3513 15 | 4210 3513 35 | 4210 3513 55 |
| 16 | 30 | 4210 3513 16 | 4210 3513 36 | 4210 3513 56 |
| 17 | 30 | 4210 3513 17 | 4210 3513 37 | 4210 3513 57 |
| 18 | 31 | 4210 3513 18 | 4210 3513 38 | 4210 3513 58 |
| 19 | 32 | 4210 3513 19 | 4210 3513 39 | 4210 3513 59 |
| 21 | 35 | 4210 3513 21 | 4210 3513 41 | 4210 3513 61 |
| 22 | 35 | 4210 3513 22 | 4210 3513 42 | 4210 3513 62 |
| 24 | 35 | 4210 3513 24 | 4210 3513 44 | 4210 3513 64 |

Measurements in mm

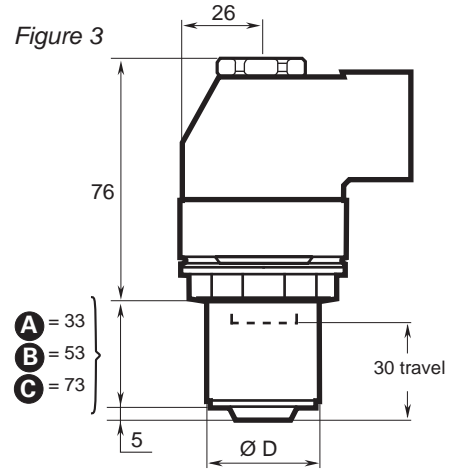

Screw holder – Two flats

| Dimension X x Y mm | Suitable socket size mm | A | Ordering No. B | C |
|--------------------------|-------------------------------|--------------|-------------------|--------------|
| 8 x 6.3 | 15-24 | 4210 2694 17 | 4210 2694 18 | 4210 2694 19 |
| 8 x 6 | 15-24 | 4210 2694 05 | 4210 2694 10 | 4210 2694 15 |
| 9.55 x 7.6 | 18-24 | 4210 2694 01 | 4210 2694 06 | 4210 2694 11 |
| 11.20 x 8.9 | 19-24 | 4210 2694 02 | 4210 2694 07 | 4210 2694 12 |
| 13 x 9.8 | 19-24 | 4210 2694 03 | 4210 2694 08 | 4210 2694 13 |
| 13.20 x 10.5 | 19-24 | 4210 2694 04 | 4210 2694 09 | 4210 2694 14 |

Two flats

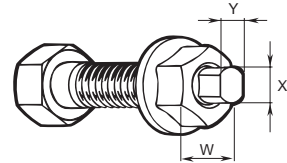

Screw holder – Male hexagon

| Dimension N mm | Suitable socket size mm | A | Ordering No. B | C |
|-------------------|-------------------------------|--------------|-------------------|--------------|
| 7 | 14-24 | 4210 2825 41 | 4210 2825 42 | 4210 2825 43 |
| 8 | 14-24 | 4210 2825 01 | 4210 2825 05 | 4210 2825 09 |
| 9 | 15-24 | 4210 2825 02 | 4210 2825 06 | 4210 2825 10 |
| 10 | 18-24 | 4210 2825 03 | 4210 2825 07 | 4210 2825 11 |
| 11 | 19-24 | 4210 2825 04 | 4210 2825 08 | 4210 2825 12 |
| 12 | 19-24 | 4210 2825 13 | 4210 2825 14 | 4210 2825 15 |

Male hexagon

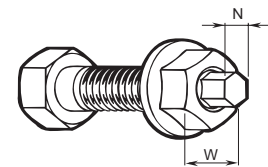

Bit holder – Female hexagon

| Bit holder 5/16" | | | 5/16" Bits | |
|------------------|--------------|--------------|-------------|--------------|
| A | B | C | Width N, mm | Ordering No. |
| 4210 2991 91 | 4210 2991 92 | 4210 2991 93 | 5 | 4023 1215 00 |
| | | | 6 | 4023 1216 00 |
| | | | 7 | 4023 1219 00 |
| | | | 8 | 4023 1217 00 |
| | | | 10 | 4023 1218 00 |

Female hexagon

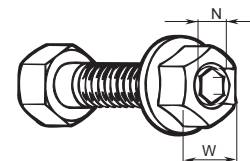

Optional Accessories for Hold and Drive tools

NUT SOCKET, SCREW HOLDER AND BIT HOLDER FOR LTV69 R370-HAD AND ETV ST101-370-HAD

Nut socket (Fig. 4)

| Width across flats W mm | Socket Ø D mm | Ordering No. | | |
|----------------------------|------------------|--------------|--------------|--------------|
| | | A | B | C |
| 18 | 41 | 4220 1778 04 | 4220 1778 14 | 4220 1778 24 |
| 19 | 41 | 4220 1778 05 | 4220 1778 15 | 4220 1778 25 |
| 20 | 41 | 4220 1778 06 | 4220 1778 16 | 4220 1778 26 |
| 21 | 41 | 4220 1778 07 | 4220 1778 17 | 4220 1778 27 |
| 22 | 41 | 4220 1778 08 | 4220 1778 18 | 4220 1778 28 |
| 23 | 41 | 4220 1778 09 | 4220 1778 19 | 4220 1778 29 |
| 24 | 41 | 4220 1778 01 | 4220 1778 11 | 4220 1778 21 |
| 25 | 41 | 4220 1778 02 | 4220 1778 12 | 4220 1778 22 |
| 25.4=1" | 41 | 4220 1778 10 | 4220 1778 20 | 4220 1778 30 |
| 26 | 41 | 4220 1778 03 | 4220 1778 13 | 4220 1778 23 |
| 27 | 46 | - | 4220 2139 84 | 4220 2139 94 |
| 28 | 46 | - | 4220 2139 83 | 4220 2139 93 |
| 29 | 46 | - | 4220 2139 82 | 4220 2139 92 |
| 30 | 46 | - | 4220 2139 81 | 4220 2139 91 |
| 31 | 54 | - | 4220 2297 81 | 4220 2297 91 |
| 32 | 54 | - | 4220 2297 82 | 4220 2297 92 |
| 33 | 54 | - | 4220 2297 83 | 4220 2297 93 |
| 34 | 54 | - | 4220 2297 84 | 4220 2297 94 |
| 35 | 54 | - | 4220 2297 85 | 4220 2297 95 |
| 36 | 54 | - | 4220 2297 86 | 4220 2297 96 |

Measurements in mm

Figure 4

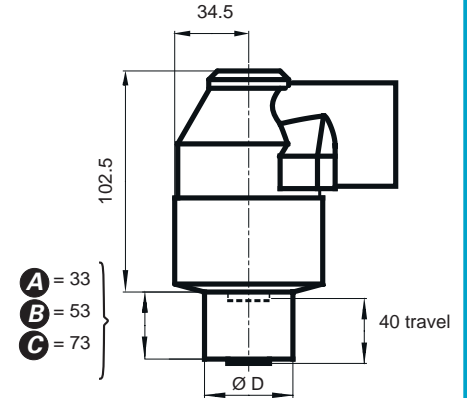

Screw holder – Two flats for LTV69 R370-HAD

| Dimension X x Y N mm | Suitable socket size mm | Ordering No. | | |
|----------------------------|-------------------------------|--------------|--------------|--------------|
| | | A | B | C |
| 13 x 9.8 | 18-36 | 4220 1777 80 | 4220 1777 83 | 4220 1777 85 |
| 13.20 x 10.5 | 18-36 | 4220 1777 81 | 4220 1777 84 | 4220 1777 86 |

Screw holder – Male hexagon for LTV69 R370-HAD

| Dimension N mm | Suitable socket size mm | Ordering No. | | |
|-------------------|-------------------------------|--------------|--------------|--------------|
| | | A | B | C |
| 10 | 18-36 | 4220 1777 52 | 4220 1777 54 | 4220 1777 72 |
| 11 | 18-36 | 4220 1777 51 | 4220 1777 50 | 4220 1777 73 |
| 12 | 20-36 | 4220 1777 53 | 4220 1777 55 | 4220 1777 74 |
| 14 | 20-36 | 4220 1777 57 | 4220 1777 56 | 4220 1777 75 |
| 16 | 24-36 | 4220 1777 58 | 4220 1777 70 | 4220 1777 76 |
| 18 | 24-36 | 4220 1777 59 | 4220 1777 71 | 4220 1777 77 |

Bit holder

| Bit holder | Socket size mm | Ordering No. | | |
|------------|-------------------|--------------|--------------|--------------|
| | | A | B | C |
| 7 | 14-24 | 4210 2825 41 | 4210 2825 42 | 4210 2825 43 |
| 5/16" | 18-20 | 4220 1777 88 | 4220 1777 89 | 4220 1777 90 |
| 5/16" | 21-36 | 4220 1777 82 | 4220 1777 85 | 4220 1777 87 |

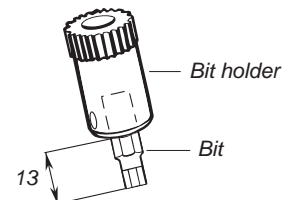

NOTE: 8 mm bit is included in the bit holders.

Productivity Kits

| Model | Max air flow | Hose 16.4 ft | Coupling | Lubrication | Ordering No. |
|--|--------------|--------------|--------------|-------------|--------------|
| For 1/2" drills and small nutrunners | | | | | |
| MIDI Optimizer F/RD EQ10US-C10 | 34 cfm | Cablair 10 | ErgoQIC 10US | Yes | 8202 0850 25 |
| MIDI Optimizer F/RD EQ10US-R10 | 34 cfm | Rubber 10 | ErgoQIC 10US | Yes | 8202 0850 26 |
| For drills and nutrunners | | | | | |
| MIDI Optimizer F/RD EQ10US-C13 | 50 cfm | Cablair 13 | ErgoQIC 10US | Yes | 8202 0850 27 |
| MIDI Optimizer F/RD EQ10US-R13 | 50 cfm | Rubber 13 | ErgoQIC 10US | Yes | 8202 0850 28 |
| For grinders, percussive tools and nutrunners | | | | | |
| MIDI Optimizer F/RD EQ10US-T13 | 65 cfm | Turbo 13 | ErgoQIC 10US | Yes | 8202 0850 29 |
| MIDI Optimizer F/R EQ10US-T13 | 65 cfm | Turbo 13 | ErgoQIC 10US | No | 8202 0850 30 |

NOTE: Tool nipple is not included in the Productivity kit and needs to be order separately together with the tool.



Service Kits

The spare parts included in the service kits cover a normal overhaul of your tool. Always have them available for a fast and economical repair.

Main parts included:

- Vane kit
- Motor bearings
- Gaskets
- O-rings
- Circlips
- Pins etc.

| Model | Service kit |
|---------|--------------|
| LTV28 | 4081 0102 90 |
| LTV29-2 | 4081 0299 90 |
| LTV38 | 4081 0103 90 |
| LTV39-2 | 4081 0298 90 |
| LTV48 | 4081 0236 90 |
| LTV69 | 4081 0397 90 |

Fast, flexible and user-friendly

The LTD system offers a flexible, low-cost solution to many advanced tightening requirements. With fixtured tools the operator influence is minimized and very high torque accuracy is achieved.

ARTICULATING ARMS

Where a fixed support on the workpiece for a reaction bar is not available, a telescopic or articulated arm mounted LTD nutrunner can be an efficient solution.

- **Reaction bar blanks** – For single spindle hand-held applications.
- **Mounting plates** – The LTD straight nutrunners have a splined reaction bar connection which can also be used for fixed assembly of the nutrunner. A number of standard mounting plates are available to order.
- **Floating square drive** – For two or more spindles the units must usually have floating spindles to compensate for run-down variations. Models with floating square drive or telescopic front parts are available.
- **Fixture punches** – For mounting of the nutrunner to locally made base plates a punch for the splines connection is available as optional equipment.
- **Air signal outlets** – All LTD models are equipped with air signal outlets for completed operation.

THE LTD SYSTEM

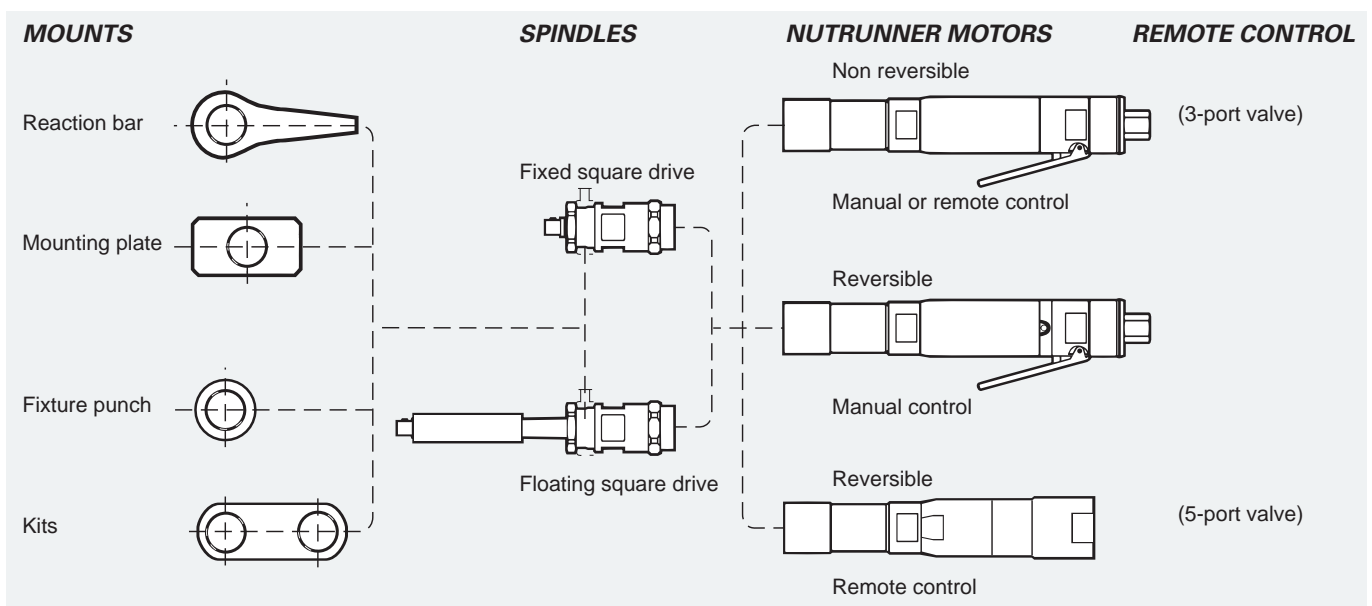

LTD28, 38 and 48 straight nutrunners are based on the power package and clutch from the LTV angle nutrunners.

LTD nutrunners are based on the unique LTP range of twin motor pistol grip nutrunners. With fast run-down and accurate final tightening they offer high productivity and unmatched torque accuracy as well as joint independence.

- Remote control back head – A remote valve is connected to the back head of the LTD-RR tools allowing a better multiple.
- Accessibility – Slim design allows the building of smooth, simple multiples or paired spindle designs. The absence of a clutch makes these tools shorter.
- Flexibility – The range of LTD tools provides you with the options you need to meet your requirements.
- Reversibility – Reversible LTD tools are available.



| Model | Bolt size mm | Square drive in | Torque range soft joint | | Free speed r/min | Weight | | Length mm | CS distance mm | Air consumption at free speed | | Rec. hose size mm | Air inlet thread in | Ordering No. |
|--|--------------|------------------|-------------------------|---------|------------------|--------|-----|-----------|----------------|-------------------------------|-----|-------------------|---------------------|--------------|
| | | | Nm | ft lb | | kg | lb | | | l/s | cfm | | | |
| Non reversible, lever start | | | | | | | | | | | | | | |
| LTD28 N18-RE | M6 | 3/8 | 8-18 | 6-13 | 780 | 1.2 | 2.6 | 358 | 20 | 9 | 19 | 10 | 1/4 | 8431 0534 08 |
| LTD28 N22-RE | M6 | 3/8 | 10-22 | 7-16 | 140 | 1.2 | 2.6 | 358 | 20 | 9 | 19 | 10 | 1/4 | 8431 0534 18 |
| Reversible, lever start | | | | | | | | | | | | | | |
| LTD28 R8-RE | M5-6 | 3/8 | 3-8 | 2-6 | 1100 | 1.2 | 2.6 | 363 | 20 | 8 | 17 | 10 | 1/4 | 8431 0534 61 |
| LTD28 R16-RE | M6 | 3/8 | 7-16 | 6-12 | 610 | 1.3 | 2.9 | 383 | 20 | 8 | 17 | 10 | 1/4 | 8431 0534 65 |
| LTD28 R20-RE | M6-8 | 3/8 | 10-20 | 7-15 | 520 | 1.3 | 2.9 | 383 | 20 | 8 | 17 | 10 | 1/4 | 8431 0534 51 |
| LTD28 R22-RE | M6-8 | 3/8 | 10-22 | 7-16 | 125 | 1.3 | 2.9 | 383 | 20 | 8 | 17 | 10 | 1/4 | 8431 0534 54 |
| Reversible, remote control back head | | | | | | | | | | | | | | |
| LTD13 R05-RR | M3-5 | 1/4 ^b | 1.5-5 | 1.1-3.7 | 850 | 0.7 | 1.6 | 197 | 16 | 7 | 15 | 8 | 1/8 | 8431 0533 05 |
| LTD13 R08-RR | M3-5 | 1/4 ^b | 1.5-8 | 1.1-6 | 500 | 0.8 | 1.7 | 197 | 16 | 7 | 15 | 8 | 1/8 | 8431 0533 06 |
| LTD28 R16-RR | M6 | 3/8 | 7-16 | 6-12 | 610 | 1.3 | 2.9 | 313 | 20 | 8 | 17 | 10/13 | ^a | 8431 0703 82 |
| LTD28 R20-RR | M6-8 | 3/8 | 10-20 | 7-15 | 520 | 1.3 | 2.9 | 313 | 20 | 8 | 17 | 10/13 | ^a | 8431 0703 83 |
| Non reversible, lever start, telescopic front part, travel 25 mm | | | | | | | | | | | | | | |
| LTD28 N18F-RE | M6 | 3/8 | 8-18 | 6-13 | 780 | 1.6 | 3.5 | 466 | 20 | 9 | 19 | 10 | 1/4 | 8431 0534 27 |
| LTD28 N21F-RE | M6 | 3/8 | 10-21 | 7-15 | 570 | 1.6 | 3.5 | 466 | 20 | 9 | 19 | 10 | 1/4 | 8431 0534 39 |
| Reversible, lever start, telescopic front part, travel 25 mm | | | | | | | | | | | | | | |
| LTD28 R16F-RE | M6 | 3/8 | 7-16 | 6-12 | 620 | 1.7 | 3.7 | 491 | 20 | 8 | 17 | 10 | 1/4 | 8431 0534 85 |
| LTD28 R20F-RE | M6-8 | 3/8 | 10-20 | 7-15 | 570 | 1.7 | 3.7 | 491 | 20 | 8 | 17 | 10 | 1/4 | 8431 0534 37 |
| LTD28 R22F-RE | M6-8 | 3/8 | 10-22 | 7-16 | 125 | 1.7 | 3.7 | 491 | 20 | 8 | 17 | 10 | 1/4 | 8431 0534 89 |
| Reversible, remote control back head, telescopic front part, travel 25 mm | | | | | | | | | | | | | | |
| LTD28 R8F-RR | M5-6 | 3/8 | 3-8 | 2-6 | 1100 | 1.6 | 3.5 | 401 | 20 | 8 | 17 | 10/13 | ^a | 8431 0703 84 |
| LTD28 R16F-RR | M6 | 3/8 | 7-16 | 6-12 | 620 | 1.7 | 3.7 | 421 | 20 | 8 | 17 | 10/13 | ^a | 8431 0703 86 |
| LTD28 R20F-RR | M6-8 | 3/8 | 10-20 | 7-15 | 570 | 1.7 | 3.7 | 421 | 20 | 8 | 17 | 10/13 | ^a | 8431 0703 88 |
| Non-reversible, lever start | | | | | | | | | | | | | | |
| LTD38 N30-RE | M8 | 1/2 | 14-30 | 10-21 | 820 | 2.2 | 4.8 | 414 | 20 | 16 | 34 | 10 | 1/4 | 8431 0535 04 |
| LTD38 N55-RE | M10 | 1/2 | 27-55 | 20-40 | 470 | 2.2 | 4.8 | 487 | 20 | 20 | 42 | 10 | 1/4 | 8431 0535 20 |
| Reversible, lever start | | | | | | | | | | | | | | |
| LTD38 R27-RE | M8 | 1/2 | 13-27 | 10-20 | 670 | 2.1 | 4.6 | 441 | 20 | 16 | 34 | 10 | 1/4 | 8431 0534 53 |
| LTD38 R32-RE | M8 | 1/2 | 18-32 | 13-24 | 560 | 2.1 | 4.6 | 441 | 20 | 16 | 34 | 10 | 1/4 | 8431 0534 52 |
| LTD38 R38-RE | M8-10 | 1/2 | 19-38 | 14-28 | 480 | 2.1 | 4.6 | 441 | 20 | 16 | 34 | 10 | 1/4 | 8431 0535 78 |
| LTD38 R47-RE | M8-10 | 1/2 | 22-47 | 16-35 | 380 | 2.3 | 5.1 | 513 | 20 | 20 | 42 | 10 | 1/4 | 8431 0535 83 |
| Reversible, remote control back head | | | | | | | | | | | | | | |
| LTD38 R27-RR | M8 | 1/2 | 13-27 | 10-20 | 670 | 2.1 | 4.6 | 377 | 21 | 16 | 34 | 10/16 | ^a | 8431 0704 22 |
| LTD38 R32-RR | M8 | 1/2 | 18-32 | 13-24 | 560 | 2.1 | 4.6 | 377 | 21 | 16 | 34 | 10/16 | ^a | 8431 0704 24 |
| LTD38 R38-RR | M8-10 | 1/2 | 19-38 | 14-28 | 480 | 2.1 | 4.6 | 377 | 21 | 16 | 34 | 10/16 | ^a | 8431 0704 26 |
| LTD38 R47-RR | M8-10 | 1/2 | 22-47 | 16-35 | 380 | 2.3 | 5.1 | 448 | 21 | 16 | 34 | 10/16 | ^a | 8431 0704 28 |

^a Air inlet thread = 2 x 1/4" + 1 x 3/8".

^c Air inlet thread = 2 x 1/2" + 1 x 3/4".

Continued...

^b 1/4" quick change chuck.

| Model | Bolt size mm | Square drive in | Torque range soft joint | | Free speed r/min | Weight | | Length mm | CS distance mm | Air consumption at free speed | | Rec. hose size mm | Air inlet thread in | Ordering No. |
|--|-----------------|--------------------|----------------------------|-------|---------------------|--------|-----|--------------|-------------------|----------------------------------|-----|----------------------|------------------------|--------------|
| | | | Nm | ft lb | | kg | lb | | | l/s | cfm | | | |
| Non-reversible, lever start, telescopic front part, travel 25 mm | | | | | | | | | | | | | | |
| LTD38 N30F-RE | M8 | 1/2 | 14-30 | 10-21 | 820 | 2.3 | 5.0 | 521 | 20 | 20 | 42 | 10 | 1/4 | 8431 0535 38 |
| LTD38 N44F-RE | M8-10 | 1/2 | 18-44 | 13-32 | 580 | 2.3 | 5.0 | 521 | 20 | 20 | 42 | 10 | 1/4 | 8431 0535 31 |
| Reversible, lever start, telescopic front part, travel 25 mm | | | | | | | | | | | | | | |
| LTD38 R27F-RE | M8 | 1/2 | 13-27 | 10-20 | 670 | 2.5 | 5.5 | 546 | 20 | 16 | 34 | 10 | 1/4 | 8431 0535 65 |
| LTD38 R32F-RE | M8 | 1/2 | 18-32 | 13-24 | 560 | 2.5 | 5.5 | 546 | 20 | 16 | 34 | 10 | 1/4 | 8431 0535 91 |
| LTD38 R47F-RE | M8-10 | 1/2 | 22-47 | 16-35 | 380 | 2.7 | 5.9 | 625 | 23 | 16 | 34 | 10 | 1/4 | 8431 0535 99 |
| Reversible, remote control back head, telescopic front part, travel 25 mm | | | | | | | | | | | | | | |
| LTD38 R27F-RR | M8 | 1/2 | 13-27 | 10-20 | 670 | 2.5 | 5.5 | 482 | 21 | 16 | 34 | 10/16 | ^a | 8431 0704 30 |
| LTD38 R32F-RR | M8 | 1/2 | 18-32 | 13-24 | 560 | 2.5 | 5.5 | 482 | 21 | 16 | 34 | 10/16 | ^a | 8431 0704 32 |
| LTD38 R38F-RR | M8-10 | 1/2 | 19-38 | 14-28 | 480 | 2.5 | 5.5 | 482 | 21 | 16 | 34 | 10/16 | ^a | 8431 0704 34 |
| LTD38 R47F-RR | M8-10 | 1/2 | 22-47 | 16-35 | 380 | 2.7 | 5.9 | 566 | 23 | 16 | 34 | 10/16 | ^a | 8431 0704 36 |
| Reversible, lever start | | | | | | | | | | | | | | |
| LTD48 R65-RE | M10 | 1/2 | 27-65 | 20-48 | 400 | 3.1 | 6.8 | 582 | 30 | 28 | 59 | 12.5 | 1/2 | 8431 0637 07 |
| LTD48 R81-RE | M12 | 1/2 | 32-81 | 24-60 | 320 | 3.1 | 6.8 | 582 | 30 | 28 | 59 | 12.5 | 1/2 | 8431 0637 12 |
| Reversible, remote control back head | | | | | | | | | | | | | | |
| LTD48 R65-RR | M10 | 1/2 | 27-65 | 20-48 | 400 | 3.5 | 7.7 | 410 | 28 | 30 | 63 | 12.5/16 | ^c | 8431 0704 46 |
| LTD48 R81-RR | M12 | 1/2 | 32-81 | 24-60 | 330 | 3.5 | 7.7 | 410 | 28 | 30 | 63 | 12.5/16 | ^c | 8431 0704 48 |
| Reversible, lever start, telescopic front part, travel 25 mm | | | | | | | | | | | | | | |
| LTD48 R65F-RE | M10 | 1/2 | 27-65 | 20-48 | 400 | 3.5 | 7.7 | 700 | 30 | 28 | 59 | 12.5 | 1/2 | 8431 0637 17 |
| LTD48 R81F-RE | M12 | 1/2 | 32-81 | 24-60 | 320 | 3.5 | 7.7 | 700 | 30 | 28 | 59 | 12.5 | 1/2 | 8431 0637 23 |
| Reversible, remote control back head | | | | | | | | | | | | | | |
| LTD48 R65F-RR | M10 | 1/2 | 27-65 | 20-48 | 400 | 3.7 | 8.2 | 522 | 28 | 30 | 63 | 12.5/16 | ^c | 8431 0704 50 |
| LTD48 R81F-RR | M12 | 1/2 | 32-81 | 24-60 | 330 | 3.7 | 8.2 | 522 | 28 | 30 | 63 | 12.5/16 | ^c | 8431 0704 52 |

^a Air inlet thread = 2 x 1/4" + 1 x 3/8".

^c Air inlet thread = 2 x 1/2" + 1 x 3/4".

^b 1/4" quick change chuck.

| Model | Bolt size mm | Square drive in | Torque range at 6.3 bar | | Min torque at 3 bar | | Free speed r/min | Weight | | Length mm | CS distance mm | Air consumption at free speed | | Air inlet thread in | Spline type | Ordering No. |
|--|-----------------|--------------------|----------------------------|---------|------------------------|-------|---------------------|--------|-----|--------------|-------------------|----------------------------------|-----|------------------------|-------------|--------------|
| | | | Nm | ft lb | Nm | ft lb | | kg | lb | | | l/s | cfm | | | |
| Torque control models with fixed square drive | | | | | | | | | | | | | | | | |
| LTD61 H100-13-RE | M12 | 1/2 | 55-100 | 40-75 | 45 | 35 | 1800 | 3.0 | 6.6 | 223 | 29 | 20 | 42 | 3/8 | 3 | 8431 0808 06 |
| LTD61 H170-13-RE | M14 | 1/2 | 95-170 | 70-125 | 70 | 50 | 1100 | 3.0 | 6.6 | 223 | 29 | 20 | 42 | 3/8 | 3 | 8431 0808 15 |
| LTD61 H230-19-RE | M16 | 3/4 | 125-230 | 90-170 | 85 | 60 | 820 | 3.0 | 6.6 | 223 | 29 | 20 | 42 | 3/8 | 3 | 8431 0808 23 |
| LTD61 H350-20-RE | M18 | 3/4 | 190-350 | 140-255 | 145 | 105 | 520 | 3.9 | 8.6 | 260 | 31 | 20 | 42 | 3/8 | 4 | 8431 0808 27 |
| LTD61 H500-20-RE | M20 | 3/4 | 275-500 | 200-370 | 220 | 160 | 360 | 3.9 | 8.6 | 260 | 31 | 20 | 42 | 3/8 | 4 | 8431 0808 36 |
| LTD61 H700-25-RE | M22 | 1 | 360-650 | 265-480 | 280 | 207 | 280 | 4.5 | 9.9 | 305 | 34 | 20 | 42 | 3/8 | 5 | 8431 0808 43 |
| LTD61 H900-25-RE | M24 | 1 | 480-870 | 350-640 | 300 | 220 | 210 | 4.5 | 9.9 | 282 | 32 | 20 | 42 | 3/8 | 5 | 8431 0808 45 |

NOTE: Change over torque is around 4% of maximum torque on a given pressure.

Dimensions

TELESCOPIC FRONT PART LTD61

| Model | Dimensions | | | | | | Ordering No. |
|------------------|------------|---------|---------|---------|---------|---------|--------------|
| | N in | D mm | F mm | L mm | M mm | t mm | |
| LTD61 H100, H170 | 1/2 | 34 | 25 | 101 | 127 | 12 | 4210 3864 80 |
| LTD61 H230 | 3/4 | 41 | 25 | 117 | 148 | 12 | 4210 3789 80 |
| LTD61 H350, H500 | 3/4 | 50 | 40 | 160 | 201 | 15 | 4210 3781 81 |
| LTD61 H700, H900 | 1 | 67 | 50 | 226 | 278 | 15 | 4210 3788 80 |

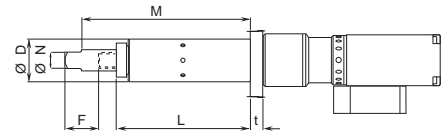

Accessories Included

FOR ALL MODELS

Torque adjustment key

Productivity Kits

| Model | Max air flow | Hose 16.4 ft | Coupling | Lubrication | Ordering No. |
|--|--------------|--------------|--------------|-------------|--------------|
| For 1/2" drills and small nutrunners | | | | | |
| MIDI Optimizer F/RD EQ10US-C10 | 34 cfm | Cablair 10 | ErgoQIC 10US | Yes | 8202 0850 25 |
| MIDI Optimizer F/RD EQ10US-R10 | 34 cfm | Rubber 10 | ErgoQIC 10US | Yes | 8202 0850 26 |
| For drills and nutrunners | | | | | |
| MIDI Optimizer F/RD EQ10US-C13 | 50 cfm | Cablair 13 | ErgoQIC 10US | Yes | 8202 0850 27 |
| MIDI Optimizer F/RD EQ10US-R13 | 50 cfm | Rubber 13 | ErgoQIC 10US | Yes | 8202 0850 28 |
| For grinders, percussive tools and nutrunners | | | | | |
| MIDI Optimizer F/RD EQ10US-T13 | 65 cfm | Turbo 13 | ErgoQIC 10US | Yes | 8202 0850 29 |
| MIDI Optimizer F/R EQ10US-T13 | 65 cfm | Turbo 13 | ErgoQIC 10US | No | 8202 0850 30 |



Service Kits



| Model | General service kit |
|-------|---------------------|
| LTD61 | 4081 0397 90 |

Optional Accessories

REACTION BAR

|  | Dimensions mm | LTD38 N55/R47 LTD48 LMD/LTD61 -13, -19 | | | | |
|---|------------------------|--|--------------|------------------|------------------|--------------|
| | | LTD28 | LTD38 | LMD/LTD61 -20 | LMD/LTD61 -25 | |
| Bar blank (steel) | L 250 200 500 | 4210 1798 00 | 4210 2134 00 | 4210 2219 82 | 4210 2183 80 | 4210 2726 80 |
| Bar blank (aluminum) | 400 | | | 4210 2219 81 | | |

MOUNTING PLATE

| | Dimensions mm | LTD38 N55/R47 LTD48 LMD/LTD61 -13, -19 | | | | |
|--|--|--|--------------|------------------|------------------|--------------|
| | | LTD28 | LTD38 | LMD/LTD61 -20 | LMD/LTD61 -25 | |
| Side mount  | L x W 90 x 40 120 x 70 | 4210 1798 01 | 4210 2134 01 | | 4210 2809 80 | 4210 2808 80 |
| Center mount  | L x W 70 x 40 100 x 50 125 x 65 | 4210 1798 02 | 4210 2134 02 | 4210 2219 03 | 4210 2183 01 | 4210 2726 01 |
| Flange mount  | D 55 | | | 4210 2219 10 | | |

VALVE KITS.

INCLUDES: MAIN VALVE, THROTTLE HANDLE VALVE/VALVES, BRACKET, HOSE NIPPLES AND HOSE CLAMPS.

| Intended for tool type | Valve type | Ordering No. |
|------------------------|---------------------------|--------------|
| LTD28/38 RE | 3-gate for non reversible | 4210 4162 80 |
| LTD28 RR | 5-gate for reversible | 4210 4163 80 |
| LTD48 RE | 3-gate for non reversible | 4210 4166 80 |
| LTD38/48 RR | 5-gate for reversible | 4210 4167 80 |
| LTD61 H100, H170, H230 | 3-gate for non reversible | 4210 4166 80 |

NOTE: Each valve kit can control two nutrunners

EXHAUST MANIFOLDS.

INCLUDES: BLOCK, SILENCER WITH GASKET AND NIPPLES.

| Intended for tool type | Ordering No. |
|------------------------|--------------|
| LTD28 RR | 4210 4168 80 |

An optimum combination of torque, speed and weight

With the range of pistol grip nutrunners from Atlas Copco you get the highest possible torque and speed in relation to the weight of the tool. Fast, accurate and highly operator friendly, the tools are available in reversible versions for maximum flexibility.

FAST AND ACCURATE

In LTP/LMP61 tools the twin motor concept provides extremely fast rundown with good torque accuracy, even on soft joints.

OPERATOR FRIENDLY

Our pistol grip nutrunners are comfortable to operate. The reaction bar eliminates reaction forces and the exhaust through the handle arrangement keeps noise levels low.

Single-handed operation combined with the low weight and perfectly balanced pistol grip design make LMP24/61 and LTP61 nutrunners safe and comfortable to use.

REVERSIBLE FOR MAXIMUM FLEXIBILITY

Being able to loosen fasteners without changing tools saves time and effort and raises productivity.



The twin motor in the 61 series gives faster production and increased accuracy with a minimum of air consumption. Torque level on LMP models depends on the pressure of the air fed to the tool, higher pressure creates higher torque.

- High torque accuracy.
- Swiveling function makes tool positioning easy on the 61 series.
- Fast rundown motor saves time.
- Extremely good torque output to weight ratio compared to single motor pistol grip nutrunners.
- Available as both reversible and non-reversible models.



| Model | Bolt size mm | Square drive in | Max torque at 6.3 bar | | Min torque at 3 bar | | Free speed r/min | Weight ^a | | Length mm | CS distance mm | Air consumption at free speed | | Air inlet thread in | Spline type | Ordering No. |
|-----------------------|-----------------|--------------------|--------------------------|-------|------------------------|-------|---------------------|---------------------|------|--------------|-------------------|----------------------------------|-----|---------------------------|----------------|--------------|
| | | | Nm | ft lb | Nm | ft lb | | kg | lb | | | l/s | cfm | | | |
| Non-reversible | | | | | | | | | | | | | | | | |
| LMP24 H005-10 | M8 | 3/8 | 30 | 22 | 14 | 10 | 500 | 1.0 | 2.2 | 210 | 18 | 11 | 23 | 1/4 | 1 | 8431 0245 49 |
| LMP24 H003-13 | M8 | 1/2 | 40 | 30 | 14 | 10 | 330 | 1.2 | 2.6 | 210 | 18 | 11 | 23 | 1/4 | 1 | 8431 0245 64 |
| LMP24 H002-13 | M10 | 1/2 | 58 | 43 | 27 | 20 | 240 | 1.3 | 2.9 | 230 | 21 | 11 | 23 | 1/4 | 2 | 8431 0245 31 |
| LMP61 H100-13 | M12 | 1/2 | 100 | 75 | 60 | 45 | 2200 | 3.0 | 6.6 | 223 | 29 | 20 | 42 | 3/8 | 3 | 8431 0803 05 |
| LMP61 H170-13 | M14 | 1/2 | 170 | 125 | 100 | 75 | 1400 | 3.0 | 6.6 | 223 | 29 | 20 | 42 | 3/8 | 3 | 8431 0803 12 |
| LMP61 H230-19 | M16 | 3/4 | 230 | 170 | 130 | 95 | 1000 | 3.0 | 6.6 | 223 | 29 | 20 | 42 | 3/8 | 3 | 8431 0803 19 |
| LMP61 H350-20 | M18 | 3/4 | 350 | 260 | 200 | 145 | 650 | 3.9 | 8.6 | 260 | 31 | 20 | 42 | 3/8 | 4 | 8431 0803 26 |
| LMP61 H500-20 | M20 | 3/4 | 500 | 370 | 300 | 220 | 450 | 3.9 | 8.6 | 260 | 31 | 20 | 42 | 3/8 | 4 | 8431 0803 33 |
| LMP61 H700-25 | M22 | 1 | 700 | 520 | 400 | 295 | 350 | 4.5 | 9.9 | 305 | 34 | 20 | 42 | 3/8 | 5 | 8431 0803 40 |
| LMP61 H900-25 | M24 | 1 | 900 | 665 | 500 | 365 | 260 | 4.5 | 9.9 | 282 | 34 | 20 | 42 | 3/8 | 5 | 8431 0803 47 |
| Reversible | | | | | | | | | | | | | | | | |
| LMP24 HR011-10 | M6 | 3/8 | 10 | 7 | 5 | 4 | 860 | 1.0 | 2.2 | 210 | 18 | 11 | 23 | 1/4 | 1 | 8431 0245 85 |
| LMP24 HR005-10 | M8 | 3/8 | 22 | 16 | 10 | 7 | 380 | 1.0 | 2.2 | 210 | 18 | 11 | 23 | 1/4 | 1 | 8431 0245 77 |
| LMP24 HR003-13 | M8 | 1/2 | 30 | 22 | 14 | 10 | 250 | 1.2 | 2.6 | 210 | 18 | 11 | 23 | 1/4 | 1 | 8431 0245 91 |
| LMP24 HR002-13 | M10 | 1/2 | 40 | 33 | 20 | 15 | 180 | 1.3 | 2.9 | 230 | 21 | 11 | 23 | 1/4 | 2 | 8431 0245 70 |
| LMP61 HR100-13 | M12 | 1/2 | 100 | 75 | 60 | 45 | 2200 | 3.0 | 6.6 | 235 | 30 | 20 | 42 | 3/8 | 3 | 8431 0804 04 |
| LMP61 HR170-13 | M14 | 1/2 | 170 | 125 | 100 | 75 | 1400 | 3.0 | 6.6 | 238 | 30 | 20 | 42 | 3/8 | 3 | 8431 0804 11 |
| LMP61 HR230-19 | M16 | 3/4 | 230 | 170 | 130 | 95 | 1000 | 3.0 | 6.6 | 275 | 34 | 20 | 42 | 3/8 | 3 | 8431 0804 18 |
| LMP61 HR350-20 | M18 | 3/4 | 350 | 260 | 200 | 145 | 650 | 3.9 | 8.6 | 275 | 34 | 20 | 42 | 3/8 | 4 | 8431 0804 25 |
| LMP61 HR500-20 | M20 | 3/4 | 500 | 370 | 300 | 220 | 450 | 3.9 | 8.6 | 320 | 35 | 21 | 42 | 3/8 | 4 | 8431 0804 32 |
| LMP61 HR700-25 | M22 | 1 | 700 | 520 | 400 | 295 | 350 | 4.5 | 9.9 | 305 | 34 | 20 | 42 | 3/8 | 5 | 8431 0804 39 |
| LMP61 HR900-25 | M24 | 1 | 900 | 665 | 500 | 365 | 260 | 4.5 | 9.9 | 305 | 34 | 20 | 42 | 3/8 | 5 | 8431 0804 46 |
| LMP61 HR1500-25 | M30 | 1 | 1600 | 1180 | 900 | 660 | 140 | 6.8 | 14.9 | 345 | 42 | 20 | 42 | 3/8 | 9 | 8431 0804 53 |

^a Weight excluding reaction bar.

NOTE: Change over torque is around 4% of maximum torque on a given air pressure.

Recommended hose (61 series) size 13 mm for hose length up to 5 m and 16 mm hose size for length 5-10 m.

- LTP61 models are equipped with twin motors and a shut-off valve to ensure that the tool shuts off when the preset torque level is reached.
- High torque accuracy.
- Extremely high torque output to weight ratio.
- A reversible tool with fixed positions for both forward and reverse.



LTP61 H900-25

| Model | Bolt size mm | Square drive in | Torque range at 6.3 bar | | Min torque at 3 bar | | Free speed r/min | Weight ^a | | Length mm | CS distance mm | Air consumption at free speed | | Air inlet thread in | Spline type | Ordering No. |
|-----------------------|--------------|-----------------|-------------------------|-----------|---------------------|-------|------------------|---------------------|------|-----------|----------------|-------------------------------|-----|---------------------|-------------|--------------|
| | | | Nm | ft lb | Nm | ft lb | | kg | lb | | | l/s | cfm | | | |
| Non reversible | | | | | | | | | | | | | | | | |
| LTP61 H100-13 | M12 | 1/2 | 55-100 | 40-75 | 45 | 35 | 1800 | 3.0 | 6.6 | 223 | 29 | 20 | 42 | 3/8 | 3 | 8431 0800 07 |
| LTP61 H170-13 | M14 | 1/2 | 95-170 | 70-125 | 70 | 50 | 1100 | 3.0 | 6.6 | 223 | 29 | 20 | 42 | 3/8 | 3 | 8431 0800 14 |
| LTP61 H230-19 | M16 | 3/4 | 125-230 | 90-170 | 85 | 60 | 820 | 3.0 | 6.6 | 223 | 29 | 20 | 42 | 3/8 | 3 | 8431 0800 21 |
| LTP61 H350-20 | M18 | 3/4 | 190-350 | 140-255 | 145 | 105 | 520 | 3.9 | 8.6 | 260 | 31 | 20 | 42 | 3/8 | 4 | 8431 0800 28 |
| LTP61 H500-20 | M20 | 3/4 | 275-500 | 200-370 | 220 | 160 | 360 | 3.9 | 8.6 | 260 | 31 | 20 | 42 | 3/8 | 4 | 8431 0800 35 |
| LTP61 H700-25 | M22 | 1 | 360-650 | 265-480 | 280 | 207 | 280 | 4.5 | 9.9 | 305 | 34 | 20 | 42 | 3/8 | 5 | 8431 0800 42 |
| LTP61 H900-25 | M24 | 1 | 480-870 | 350-640 | 300 | 220 | 210 | 4.5 | 9.9 | 282 | 32 | 20 | 42 | 3/8 | 5 | 8431 0800 49 |
| LTP61 H1500-25 | M30 | 1 | 850-1500 | 625-1100 | 700 | 516 | 115 | 6.8 | 14.5 | 323 | 42 | 20 | 42 | 3/8 | 9 | 8431 0800 56 |
| Reversible | | | | | | | | | | | | | | | | |
| LTP61 HR100-13 | M12 | 1/2 | 55-100 | 40-75 | 45 | 35 | 1800 | 3.0 | 6.6 | 235 | 30 | 20 | 42 | 3/8 | 3 | 8431 0801 08 |
| LTP61 HR170-13 | M14 | 1/2 | 95-170 | 70-125 | 70 | 50 | 1100 | 3.0 | 6.6 | 238 | 30 | 20 | 42 | 3/8 | 3 | 8431 0801 15 |
| LTP61 HR230-19 | M16 | 3/4 | 125-230 | 90-170 | 85 | 60 | 820 | 3.0 | 6.6 | 275 | 34 | 20 | 42 | 3/8 | 3 | 8431 0801 22 |
| LTP61 HR350-20 | M18 | 3/4 | 190-350 | 140-255 | 145 | 105 | 520 | 3.9 | 8.6 | 275 | 34 | 20 | 42 | 3/8 | 4 | 8431 0801 29 |
| LTP61 HR500-20 | M20 | 3/4 | 275-500 | 200-370 | 220 | 160 | 360 | 3.9 | 8.6 | 275 | 34 | 20 | 42 | 3/8 | 4 | 8431 0801 36 |
| LTP61 HR700-25 | M22 | 1 | 360-650 | 265-480 | 280 | 207 | 280 | 4.5 | 9.9 | 305 | 34 | 20 | 42 | 3/8 | 5 | 8431 0801 43 |
| LTP61 HR900-25 | M24 | 1 | 480-870 | 350-640 | 300 | 220 | 210 | 4.5 | 9.9 | 305 | 34 | 20 | 42 | 3/8 | 5 | 8431 0801 50 |
| LTP61 HR1500-25 | M30 | 1 | 850-1500 | 625-1100 | 700 | 516 | 115 | 6.8 | 14.5 | 345 | 42 | 20 | 42 | 3/8 | 9 | 8431 0801 57 |
| LTP61 HR1900-38 | M30 | 1 1/2 | 1050-1900 | 770-1400 | 800 | 590 | 90 | 14.1 | 31.0 | 380 | 68 | 20 | 42 | 3/8 | 8 | 8431 0801 64 |
| LTP61 HR2800-38 | M36 | 1 1/2 | 1550-2800 | 1140-2060 | 1200 | 885 | 65 | 14.1 | 31.0 | 380 | 68 | 20 | 42 | 3/8 | 8 | 8431 0801 71 |
| LTP61 HR3800-38 | M42 | 1 1/2 | 2100-3800 | 1540-2800 | 1600 | 1180 | 50 | 14.1 | 31.0 | 380 | 68 | 20 | 42 | 3/8 | 8 | 8431 0801 78 |

^a Without reaction bar.

NOTE: Change over torque is around 4% of maximum torque on a given air pressure.

Recommended hose size 13 mm for hose length up to 5 m and 16 mm hose size for length 5-10 m.

FOR PREVAILING APPLICATIONS

- LTP61 PH is specially designed to handle prevailing applications, such as locking nuts.
- Special gear gives a higher change-over torque.
- Fast rundown motor handles most of the rundown before the slower but stronger tightening motor is used.



LTP61 PH900-25

| Model | Bolt size mm | Square drive in | Torque range at 6.3 bar | | Min torque at 3 bar | | Free speed r/min | Weight ^a | | Length mm | CS distance mm | Air consumption at free speed | | Air inlet thread in | Spline type | Ordering No. |
|--|-----------------|--------------------|----------------------------|----------|------------------------|-------|---------------------|---------------------|------|--------------|----------------------|----------------------------------|-----|---------------------------|----------------|--------------|
| | | | Nm | ft lb | Nm | ft lb | | kg | lb | | | l/s | cfm | | | |
| Non-reversible | | | | | | | | | | | | | | | | |
| LTP61 PH100-13 | M12 | 1/2 | 60-110 | 45-80 | 45 | 33 | 700 | 3.0 | 6.6 | 223 | 34 | 20 | 42 | 3/8 | 3 | 8431 0807 04 |
| LTP61 PH170-13 | M14 | 1/2 | 100-180 | 75-135 | 70 | 52 | 440 | 3.0 | 6.6 | 223 | 34 | 20 | 42 | 3/8 | 3 | 8431 0807 12 |
| LTP61 PH230-19 | M16 | 3/4 | 130-240 | 95-180 | 90 | 66 | 320 | 3.0 | 6.6 | 223 | 34 | 20 | 42 | 3/8 | 3 | 8431 0807 17 |
| LTP61 PH350-20 | M18 | 3/4 | 210-370 | 155-275 | 150 | 110 | 200 | 3.9 | 8.6 | 260 | 34 | 20 | 42 | 3/8 | 4 | 8431 0807 24 |
| LTP61 PH500-20 | M20 | 3/4 | 300-520 | 220-380 | 200 | 150 | 140 | 3.9 | 8.6 | 260 | 34 | 20 | 42 | 3/8 | 4 | 8431 0807 31 |
| LTP61 PH700-25 | M22 | 1 | 400-680 | 295-500 | 280 | 205 | 100 | 4.5 | 9.9 | 305 | 34 | 20 | 42 | 3/8 | 5 | 8431 0807 38 |
| LTP61 PH900-25 | M24 | 1 | 500-900 | 370-665 | 350 | 260 | 80 | 4.5 | 9.9 | 282 | 34 | 20 | 42 | 3/8 | 5 | 8431 0807 41 |
| LTP61 PH1500-25 | M30 | 1 | 900-1600 | 665-1180 | 650 | 480 | 45 | 6.8 | 14.9 | 323 | 42 | 20 | 42 | 3/8 | 9 | 8431 0807 52 |
| Reversible | | | | | | | | | | | | | | | | |
| LTP61 PHR700-25 | M22 | 1 | 400-680 | 295-500 | 280 | 205 | 100 | 4.5 | 9.9 | 305 | 34 | 20 | 42 | 3/8 | 5 | 8431 0807 55 |
| LTP61 PHR900-25 | M24 | 1 | 500-900 | 370-665 | 350 | 260 | 80 | 4.5 | 9.9 | 305 | 34 | 20 | 42 | 3/8 | 5 | 8431 0807 62 |
| LTP61 PHR1500-25 | M30 | 1 | 900-1600 | 665-1180 | 650 | 480 | 45 | 6.8 | 14.9 | 345 | 42 | 20 | 42 | 3/8 | 9 | 8431 0807 68 |
| Reversible with Multi Torque unit | | | | | | | | | | | | | | | | |
| LTP61 PHR900-25-MT | M24 | 1 | 500-900 | 370-665 | 350 | 260 | 80 | 4.8 | 10.6 | 305 | 34 | 20 | 42 | 3/8 | 5 | 8431 0807 81 |

^a Without reaction bar.

Recommended hose size 13 mm for hose length up to 5 m and 16 mm hose size for length 5-10 m.

NOTE: Change over torque is around 10% of maximum torque on a given air pressure.

LTP WITH MULTITORQUE SELECTOR

- The Multi Torque Selector makes it possible to preset up to four different shut-off levels.
- The Rotary dial mounted on the tool allows the operator to select different torque levels without changing the tool.
- Ideal for situations where:
 - Several different assembly operations take place.
 - Multi-stage tightening operations are required.
 - Several different torque settings are needed.
- Reverse function that has fixed positions for both forward and reverse.



LTP61 HR900-25-MT

| Model | Bolt size mm | Square drive in | Torque range at 6.3 bar | | Min torque at 3 bar | | Free speed r/min | Weight ^a | | Length mm | CS distance mm | Air consumption at free speed | | Air inlet thread in | Spline type | Ordering No. |
|--------------------|-----------------|--------------------|----------------------------|----------|------------------------|-------|---------------------|---------------------|------|--------------|----------------------|----------------------------------|-----|---------------------------|----------------|--------------|
| | | | Nm | ft lb | Nm | ft lb | | kg | lb | | | l/s | cfm | | | |
| LTP61 HR100-13-MT | M12 | 1/2 | 55-100 | 40-75 | 45 | 35 | 1800 | 3.3 | 7.3 | 273 | 30 | 20 | 42 | 3/8 | 3 | 8431 0806 02 |
| LTP61 HR170-13-MT | M14 | 1/2 | 95-170 | 70-125 | 70 | 50 | 1100 | 3.3 | 7.3 | 273 | 30 | 20 | 42 | 3/8 | 3 | 8431 0806 09 |
| LTP61 HR230-19-MT | M16 | 3/4 | 125-230 | 90-170 | 85 | 60 | 820 | 3.3 | 7.3 | 273 | 34 | 20 | 42 | 3/8 | 3 | 8431 0806 16 |
| LTP61 HR350-20-MT | M18 | 3/4 | 190-350 | 140-255 | 145 | 105 | 520 | 4.2 | 9.2 | 310 | 34 | 20 | 42 | 3/8 | 4 | 8431 0806 23 |
| LTP61 HR500-20-MT | M20 | 3/4 | 275-500 | 200-370 | 220 | 160 | 360 | 4.2 | 9.2 | 310 | 34 | 20 | 42 | 3/8 | 4 | 8431 0806 30 |
| LTP61 HR700-25-MT | M22 | 1 | 360-650 | 265-480 | 280 | 207 | 280 | 4.8 | 10.6 | 340 | 34 | 20 | 42 | 3/8 | 5 | 8431 0806 33 |
| LTP61 HR900-25-MT | M24 | 1 | 480-870 | 350-640 | 300 | 220 | 210 | 4.8 | 10.6 | 340 | 34 | 20 | 42 | 3/8 | 5 | 8431 0806 37 |
| LTP61 HR1500-25-MT | M30 | 1 | 850-1500 | 625-1100 | 700 | 516 | 115 | 7.1 | 15.6 | 379 | 42 | 20 | 42 | 3/8 | 9 | 8431 0806 44 |

^aWithout reaction bar.

Recommended hose size 13 mm for hose length up to 5 m and 16 mm hose size for length 5-10 m.

NOTE: Change over torque is around 4% of maximum torque on a given air pressure.

Productivity Kits

| Model | Max air flow | Hose 16.4 ft | Coupling | Lubrication | Ordering No. |
|--|--------------|--------------|--------------|-------------|--------------|
| For 1/2" drills and small nutrunners | | | | | |
| MIDI Optimizer F/RD EQ10US-C10 | 34 cfm | Cablair 10 | ErgoQIC 10US | Yes | 8202 0850 25 |
| MIDI Optimizer F/RD EQ10US-R10 | 34 cfm | Rubber 10 | ErgoQIC 10US | Yes | 8202 0850 26 |
| For drills and nutrunners | | | | | |
| MIDI Optimizer F/RD EQ10US-C13 | 50 cfm | Cablair 13 | ErgoQIC 10US | Yes | 8202 0850 27 |
| MIDI Optimizer F/RD EQ10US-R13 | 50 cfm | Rubber 13 | ErgoQIC 10US | Yes | 8202 0850 28 |
| For grinders, percussive tools and nutrunners | | | | | |
| MIDI Optimizer F/RD EQ10US-T13 | 65 cfm | Turbo 13 | ErgoQIC 10US | Yes | 8202 0850 29 |
| MIDI Optimizer F/R EQ10US-T13 | 65 cfm | Turbo 13 | ErgoQIC 10US | No | 8202 0850 30 |

NOTE: Tool nipple is not included in the Productivity kit and needs to be order separately together with the tool.

Accessories Included

FOR LMP24

Suspension yoke, reaction bar

FOR LMP/LTP61

Suspension yoke
Protective cover is included

Optional Accessories

FOR LMP24

| Model | Ordering No. |
|--|--------------|
| Hose nipple | 9000 0247 00 |
| Swivel attachment | 4210 2249 80 |
| Exhaust hose | 4210 2053 00 |
| Support handle (for H/HR002 only) | 4110 1355 82 |
| Spindle extension 115 mm x 1/2" (for H/HR002 only) | 4210 2154 80 |
| 50 mm x 3/8" (for H/HR011/005 only) | 4210 2158 80 |
| 1/4" hex bit holder (for H/HR011/005 only) | 4021 0443 00 |
| 1/2" square adapter (for H/HR011/005 only) | 4210 2157 80 |

FOR LMP/LTP61

| Model | Ordering No. |
|---|--|
| Hose nipple | 9000 0242 00 |
| Exhaust hose | 4210 2201 00 |
| Protective cover Standard LTP61 LTP 61 with MT unit | 4210 4672 00 4210 4672 01 |
| Multi torque selector LTP61 | 4210 4636 95 |
| Quick change retainer – 1/2" square models – 3/4" square models – 1" square models | 4250 1190 00 4210 3476 80 4210 3524 80 |
| Shut-off override for LTP61 | 4210 3545 80 |
| Swivelling type MultiFlex connector 3/8" (BSP) | 8202 1350 22 |
| Swivelling type MultiFlex connector 3/8" (NPT) | 8202 1350 28 |



Multi torque selector LTP61



Protective cover

SWIVELLING SUSPENSION YOKE LMP/LTP61

| Model | Ordering No. |
|-----------------------------|--------------|
| Mounting dia Ø 54 mm | 4210 3088 80 |
| PH/H 100-13 | |
| PH/H 170-13 | |
| PH/H 230-19 | |
| PH/H 350-20 | |
| PH/H 500-20 | |
| PH/H 700-25 | |
| PH/H 900-25 | |
| Mounting dia Ø 60 mm | 4210 3088 84 |
| HR 100-13 | |
| HR 170-13 | |
| HR 230-19 | |

| Model | Ordering No. |
|-------------------------------|--------------|
| Mounting dia Ø 63.5 mm | 4210 3088 83 |
| H 1900-38 | |
| H 2800-38 | |
| H 3800-38 | |
| Mounting dia Ø 67 mm | 4210 3088 82 |
| HR 350-20 | |
| HR 500-20 | |
| PHR/HR 700-25 | |
| PHR/HR 900-25 | |
| HR 1900-38 | 4210 3088 85 |
| HR 2800-38 | |
| HR 3800-38 | |

| Model | Ordering No. |
|-------------------------------|--------------|
| Mounting dia Ø 83.5 mm | 4210 3088 81 |
| PH/H 1500-25 | |
| PHR/HR 1500-25 | |

REACTION BARS LMP/LTP 61

| Spline dia mm | Square drive size mm/in | CC distance mm | Ordering No. |
|--|-------------------------|----------------|--------------|
| Steel bar | | | |
| Spline 1 | 268/36/18 | | 4210 1798 01 |
| Spline 2 | 270/35/10 | | 4220 1903 00 |
| Spline 3 | 400/56/12 | | 4210 2219 80 |
| Spline 4 | 500/62/15 | | 4210 2183 80 |
| Spline 5 | 500/62/15 | | 4210 2726 80 |
| Spline 6 | 560/80/15 | | 4220 1200 01 |
| Spline 8 | 500/150/20 | | 4210 3899 03 |
| Spline 9 | 500/85/20 | | 4210 3899 80 |
| Square steel bracket | | | |
| Spline 3 | 100/50/12 | | 4210 2219 03 |
| Spline 4 | 125/65/16 | | 4210 2183 01 |
| Spline 5 | 125/65/16 | | 4210 2726 01 |
| Spline 6 | 200/100/15 | | 4220 1200 00 |
| Spline 7 | 250/150/20 | | 4220 1445 00 |
| Spline 8 | 250/160/20 | | 4220 1972 91 |
| Spline 9 | 150/85/20 | | 4210 3899 01 |
| Triangular steel bracket | | | |
| Spline 2 | 73/72/14 | | 4220 2137 02 |
| Spline 3 | 82/80/15 | | 4220 2137 03 |
| Spline 6 | 112/109/15 | | 4220 2137 06 |
| Spline 6 | 150/145/20 | | 4220 2137 16 |
| Sliding drive reaction bar | | | |
| Spline 3 | 1/2 | 70-120 | 4210 4481 83 |
| Spline 3 | 3/4 | 70-120 | 4210 4481 63 |
| Spline 3 | 1/2 | 82-218 | 4210 4616 83 |
| Spline 3 | 3/4 | 82-218 | 4210 4616 63 |
| Spline 4 | 3/4 | 76-126 | 4210 4481 84 |
| Spline 4 | 3/4 | 82-218 | 4210 4616 84 |
| Spline 5 | 1 | 80-125 | 4210 4481 85 |
| Spline 5 | 1 | 82-218 | 4210 4616 85 |
| Spline 9 | 1 | 80-130 | 4210 4481 89 |
| Spline 9 | 1 | 80-280 | 4210 4616 89 |
| S-Type reaction bar | | | |
| Spline 3 | 110/18/12 | | 4210 4480 03 |
| Spline 4 | 120/22/15 | | 4210 4480 04 |
| Spline 5 | 130/25/15 | | 4210 4480 05 |
| Spline 6 | 125/25/15 | | 4210 4480 06 |
| Spline 8 | 200/65/20 | | 4210 4480 08 |
| Spline 9 | 160/40/20 | | 4210 4480 09 |
| L-Type aluminum bar | | | |
| Spline 3 | 266x300/29/15 | | 4210 2219 08 |
| Spline 4 | 144x150/42/15 | | 4210 2183 08 |
| Straight aluminum bar | | | |
| Spline 3 | L = 400 | | 4210 2219 01 |
| Extended sliding drive reaction bar | | | |
| Spline 5 | 1 | 68-112 | 4210 4498 80 |
| Extended sliding tube reaction bar | | | |
| Spline 5 | 1 | 68-112 | 4210 4498 82 |
| Bracket stepped | | | |
| Spline 1 | 70/36/13 | | 4210 1798 02 |
| Spline 2 | 70/41/14 | | 4210 2134 02 |

Steel bar



Square steel bracket



Triangular steel bracket



Sliding drive reaction bar



S-Type reaction bar



L-Type aluminum bar



Straight aluminum bar



Extended sliding drive reaction bar



Extended sliding tube reaction bar



Bracket stepped

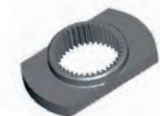

Service Kits

| Model | Trigger kit | General service kit |
|-----------|--------------|---------------------|
| LMP24 | 4210 1934 91 | 4081 0105 90 |
| LMP/LTP61 | 4210 2190 91 | 4081 0397 90 |

RTP NUTRUNNERS FOR HEAVY DUTY BOLTING

- RTP's slim gearpack gives you effortless access to bolts in cramped spaces.
- The torque output of the RTP is adjusted with an Atlas Copco FRL air pressure unit, helping to prolong the lifetime and torque accuracy of the tool.
- The tool's 1" exchangeable drive simplifies maintenance and cuts repair costs.



RTP4100



RTP1300

| Model | Bolt size mm | Square drive in | Min torque at 1.5 bar | | Max torque at 6.3 bar | | Free speed r/min | Weight ^a | | Length mm | CS distance mm | Air consumption at free speed | | Rec. hose size mm | Air inlet thread in | Ordering No. ^b |
|--------------|--------------|-----------------|-----------------------|-------|-----------------------|-------|------------------|---------------------|------|-----------|----------------|-------------------------------|------|-------------------|---------------------|---------------------------|
| | | | Nm | ft lb | Nm | ft lb | | kg | lb | | | l/s | cfm | | | |
| RTP1300-HR20 | 20-27 | 3/4 | 320 | 235 | 1300 | 960 | 20 | 3.7 | 8.2 | 248 | 32 | 23 | 48.7 | 13 | 3/8 | 8431 1013 10 |
| RTP4100-HR25 | 30-45 | 1 | 1000 | 738 | 4100 | 3100 | 10 | 8.7 | 19.2 | 335 | 41 | 31 | 65.5 | 13 | 3/8 | 8431 1040 10 |

^aWeight excluding reaction bar. ^bKit with included accessories, reaction bar, nipple and FRL stand.

Included Accessories

| Model | Description | Ordering No. |
|----------------|--|--------------|
| RTP1300 | Reaction bar, S-type | 4210 4480 90 |
| RTP4100 | Reaction bar, S-type | 4210 4480 93 |
| RTP1300 / 4100 | Nipple, NIP 10US, NPT | 8202 1210 79 |
| RTP1300 / 4100 | Productivity kit FRL stand, NPT ^c | 9090 3030 01 |

^cHose included.



Reaction bar, S-type



Productivity kit



Reaction bar, sliding-drive



Reaction bar, steel bar



Reaction bar, square bracket

Optional Accessories

| Model | Description | Ordering No. |
|----------------|------------------------------|--------------|
| RTP1300 / 4100 | MultiFlex swivel 3/8 NPT | 8202 1350 28 |
| | Trigger guard | 4210 4759 90 |
| RTP1300 | Reaction bar, sliding-drive | 4210 4752 90 |
| | Reaction bar, steel bar | 4210 4757 90 |
| | Reaction bar, square bracket | 4210 4758 90 |
| RTP4100 | Reaction bar, sliding-drive | 4210 4752 91 |
| | Reaction bar, steel bar | 4210 4757 91 |
| | Reaction bar, square bracket | 4210 4758 91 |

NOTE: All reaction bars includes a snap ring



Service Kits

| Model | Description | Ordering No. |
|---------|------------------------------|--------------|
| RTP1300 | Gear / Motor housing | 4082 0125 90 |
| | Gear / Motor / Motor housing | 4081 0510 90 |
| RTP4100 | Gear / Motor housing | 4082 0116 91 |
| | Gear / Motor / Motor housing | 4081 0504 90 |

Re Assembly Qualifier II

The RE Assembly Qualifier II provides your operator with visual and audio feedback for error-proofing single or multiple fastener assemblies. When used with a pressure ported pneumatic assembly tool, the RE Assembly Qualifier II verifies fastener installation and fastener count by monitoring pressure differentials during the fastening cycle. The RE Qualifier II monitors internal tool air pressure according to joint characteristics during the assembly process. Your operator will be notified if a correct or an incorrect fastening (such as a re-hit, cross-thread or early trigger release) has occurred. Atlas Copco brings you an intelligent product for error-proofing your fastener assemblies.

- Error-proofing for pneumatic shut-off assembly tools: RE pulse tools, RE screwdrivers and RE nutrunners.
- Verifies fastener installation "Accept/Reject".
- Verifies fastener count.
- Provides audio and visual operator feedback.
- AutoCal™ automatically determines tool type, pulse or continuous drive.
- Password protected.
- External transducer with OK and NOK lights.
- On-screen graphs.
- Stores 1,000 rundowns.
- Dimensions: 8" base, 10" height and 3.3" depth.



RE Assembly Qualifier II

| Model | Ordering No. |
|---|---------------------------|
| RE Assembly Qualifier II with Standard Cable Transducer | 9810 7050 80 ^a |
| RE Assembly Qualifier II, No transducers | 9810 7050 84 |
| Standard Cable Transducer | 9810 7050 86 |
| Coil Cable Transducer | 9810 7050 88 |
| Device Net Module | 9810 7050 90 |
| Hood for 12 Pin Connector | 9810 7050 92 |
| Software & Manual (Included as standard with RE Assembly Qualifier) | 9810 7050 94 |

^a Includes all components needed for a standard reporting installation.

HYDRAULIC TOOLS



Contents

| | |
|--------------------------------|----|
| Introduction..... | 72 |
| RT wrenches, square drive..... | 73 |
| RTX wrenches, low profile..... | 76 |

Introduction – Hydraulic Torque Wrenches

Hydraulic torque wrenches

When designing Atlas Copco Hydraulic Torque Wrenches for very high torque applications, such as torquing flanges, the vision was to build tools that could be relied upon to achieve safe connections in some of the world's most critical applications. From design to manufacturing and calibration, Atlas Copco Hydraulic Torque Wrenches are dedicated to this vision.

Atlas Copco is your reliable partner that gives you access to a complete line of bolt torquing tools to boost your productivity and minimize downtime.

The RT and RTX series hydraulic torque wrenches are robust and accurate hydraulic torque wrenches. The products are available in square drive RT, and RTX low profile models, this is the cornerstone for high torque applications. The hydraulic torque wrenches work with 700 bar/10,000 psi hydraulic pump.

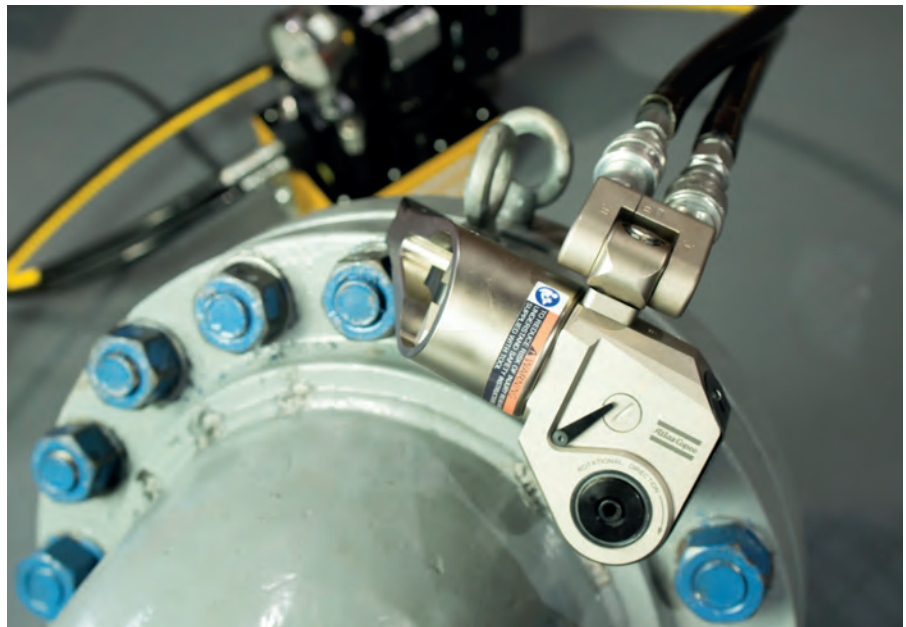

Selection Guide

TORQUE CHART

The torque is important to ensure the required clamping force is applied. The chart shows the tightening torque range for the different models in the hydraulic torque wrench product portfolio.

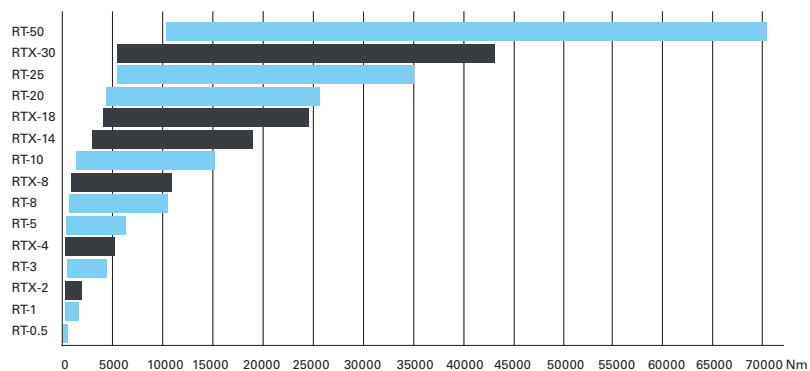

HOW TO SELECT THE LINK SIZE

Sizes are expressed as MM for metric while imperial have a 3 digit designation. First number indicates inch, and the following two numbers indicate an increment of 1/16".

For example: RL 18-308 would be a link that is 3-8/16, with 8/16 being 1/2. Another example, RL04-105 would be a 1-5/16" link. When the link size in metric and imperial are the same size, it is listed together. For example: RL 14-104/32MM would be a link for a nut that is 1-1/4 (4/16 being 1/4) but would also be used for a 32MM nut.

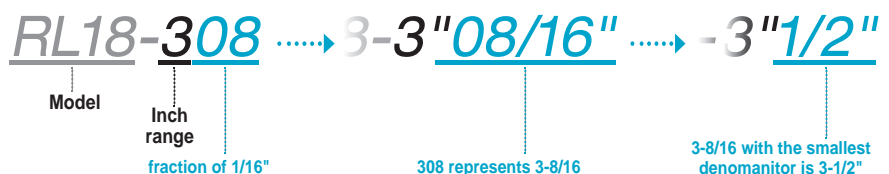

Atlas Copco Square Drive Hydraulic Torque Wrenches offer extremely high torquing power. There are 9 models to choose from and output accuracy is at +/-3%.*

* As per NIST standards.



Square drive profile

| Model | Square drive in | Torque | | | | Weight | | Ordering No. |
|--------|-----------------|--------|-------|-------|-------|--------|------|--------------|
| | | Nm | | ft lb | | kg | lb | |
| | | min | max | min | max | | | |
| RT-0.5 | 1/2 | 75 | 538 | 55 | 397 | 0.4 | 0.8 | 8434 2010 00 |
| RT-1 | 3/4 | 271 | 1817 | 200 | 1340 | 1.9 | 3.8 | 8434 2010 02 |
| RT-3 | 1 | 651 | 4379 | 480 | 3230 | 3.9 | 7.8 | 8434 2010 05 |
| RT-5 | 1-1/2 | 1132 | 7578 | 835 | 5590 | 7.5 | 15 | 8434 2010 09 |
| RT-8 | 1-1/2 | 1627 | 10845 | 1200 | 8000 | 11.5 | 23 | 8434 2010 13 |
| RT-10 | 1-1/2 | 2379 | 15617 | 1755 | 11520 | 13.4 | 26.8 | 8434 2010 16 |
| RT-20 | 2-1/2 | 4013 | 26787 | 2960 | 19760 | 18 | 36 | 8434 2010 20 |
| RT-25 | 2-1/2 | 5368 | 35096 | 3960 | 25890 | 31 | 62 | 8434 2010 25 |
| RT-50 | 2-1/2 | 10675 | 71169 | 7875 | 52500 | 48 | 96 | 8434 2010 29 |

Dimensions

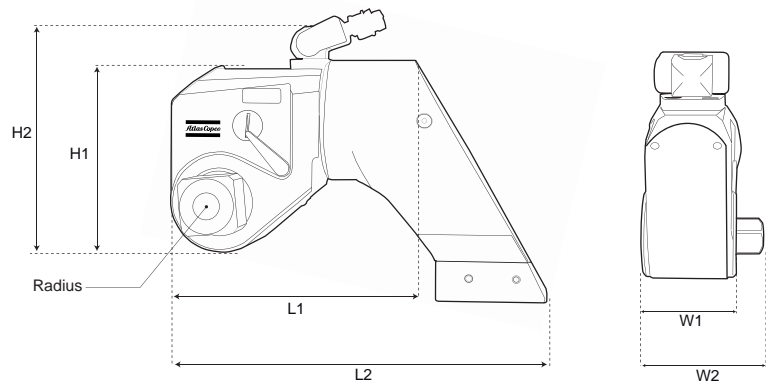

| Model | L1 | | L2 | | H1 | | H2 | | Radius | | W1 | | W2 | |
|--------|-----|------|-----|-------|-------|------|--------|------|--------|------|------|------|-------|------|
| | mm | in | mm | in | mm | in | mm | in | mm | in | mm | in | mm | in |
| RT-0.5 | 81 | 3.15 | 125 | 4.87 | 60.5 | 2.35 | 93 | 3.62 | 13.5 | 0.52 | 33.5 | 1.3 | 50.5 | 1.97 |
| RT-1 | 120 | 4.68 | 183 | 7.13 | 90.5 | 3.52 | 122 | 4.75 | 23 | 0.9 | 50 | 1.95 | 71 | 2.76 |
| RT-3 | 155 | 6.04 | 237 | 9.24 | 120 | 4.68 | 156 | 6.08 | 33 | 1.28 | 66.5 | 2.59 | 95.5 | 3.72 |
| RT-5 | 185 | 7.21 | 288 | 11.23 | 144.5 | 5.63 | 181 | 7.05 | 37 | 1.44 | 80 | 3.12 | 126 | 4.9 |
| RT-8 | 202 | 7.85 | 321 | 12.49 | 164.6 | 6.42 | 213.36 | 8.4 | 41 | 1.62 | 88 | 3.48 | 126 | 4.95 |
| RT-10 | 232 | 9 | 357 | 13.9 | 186 | 7.2 | 239 | 9.3 | 48 | 1.87 | 100 | 3.9 | 142.5 | 5.5 |
| RT-20 | 259 | 10.2 | 420 | 16.55 | 216 | 8.5 | 251 | 9.9 | 55.1 | 2.17 | 119 | 4.7 | 170 | 6.7 |
| RT-25 | 310 | 12 | 473 | 18.4 | 234 | 9.1 | 282 | 11 | 61 | 2.37 | 134 | 5.2 | 191 | 7.4 |
| RT-50 | 390 | 15.2 | 615 | 23.9 | 294 | 11.4 | 344 | 13.4 | 79 | 3.08 | 167 | 6.5 | 228 | 8.9 |

DIRECT HEX, SQUARE DRIVE REPLACEMENT

RT square drive

| Model | Hex size | Ordering No. | Model | Hex size | Ordering No. |
|------------------|----------|--------------|------------------|----------|--------------|
| RT0.5-HX-10MM | 10 mm | 8434 2138 44 | RT03-HX-24MM-EXT | 24 mm | 8434 2116 25 |
| RT0.5-HX-12MM | 12 mm | 8434 2138 47 | RT03-HX-27MM | 27 mm | 8434 2057 28 |
| RT0.5-HX-14MM | 14 mm | 8434 2138 50 | RT03-HX-30MM | 30 mm | 8434 2139 46 |
| RT0.5-HX-16MM | 16 mm | 8434 2138 53 | RT03-HX-32MM | 32mm | 8434 2057 30 |
| RT0.5-HX-17MM | 17 mm | 8434 2138 56 | RT03-HX-36MM | 36 mm | 8434 2139 49 |
| RT0.5-HX-18MM | 18 mm | 8434 2138 59 | RT03-HX-36MM-EXT | 36 mm | 8434 2139 52 |
| RT0.5-HX-19MM | 19 mm | 8434 2138 62 | RT03-HX-38MM | 38 mm | 8434 2139 55 |
| RT0.5-HX-20MM | 20 mm | 8434 2138 65 | RT03-HX-100 | | 8434 2057 20 |
| RT0.5-HX-22MM | 22 mm | 8434 2138 68 | RT05-HX-24MM | 24 mm | 8434 2140 03 |
| RT0.5-HX-24MM | 24 mm | 8434 2101 71 | RT05-HX-27MM | 27 mm | 8434 2057 36 |
| RT01-HX-010 | 5/8" | 8434 2138 71 | RT05-HX-27MM-EXT | 27 mm | 8434 2140 09 |
| RT01-HX-012 | 3/4" | 8434 2138 74 | RT05-HX-32MM | 32 mm | 8434 2140 12 |
| RT01-HX-014 | 7/8" | 8434 2138 77 | RT05-HX-32MM-EXT | 32 mm | 8434 2140 15 |
| RT01-HX-17MM | 17 mm | 8434 2056 96 | RT05-HX-36MM | 36 mm | 8434 2057 38 |
| RT01-HX-19MM | 19 mm | 8434 2056 98 | RT05-HX-41MM | 41 mm | 8434 2057 40 |
| RT01-HX-20MM | 20 mm | 8434 2057 00 | RT05-HX-41MM-EXT | 41 mm | 8434 2140 18 |
| RT01-HX-22MM | 22 mm | 8434 2057 02 | RT05-HX-46MM | 46 mm | 8434 2057 42 |
| RT01-HX-24MM | 24 mm | 8434 2057 04 | RT05-HX-55MM | 55 mm | 8434 2140 21 |
| RT01-HX-27MM | 27 mm | 8434 2057 06 | RT08-HX-24MM | 24 mm | 8434 2140 45 |
| RT03-HX-010 | 5/8" | 8434 2057 14 | RT08-HX-27MM | 27 mm | 8434 2140 48 |
| RT03-HX-012 | 3/4" | 8434 2057 16 | RT10-HX-32MM | 32 mm | 8434 2140 75 |
| RT03-HX-014 | 7/8" | 8434 2057 18 | RT10-HX-36MM | 36 mm | 8434 2057 46 |
| RT03-HX-19MM | 19 mm | 8434 2057 22 | RT10-HX-41MM | 41 mm | 8434 2057 48 |
| RT03-HX-19MM-EXT | 19 mm | 8434 2139 40 | RT10-HX-46MM | 46 mm | 8434 2057 50 |
| RT03-HX-22MM | 22 mm | 8434 2057 24 | RT10-HX-46MM-EXT | 46 mm | 8434 2140 78 |
| RT03-HX-22MM-EXT | 22 mm | 8434 2116 22 | RT10-HX-50MM | 50 mm | 8434 2057 52 |
| RT03-HX-24MM | 24 mm | 8434 2057 26 | | | |

EXT=Extended



Square drive

INSERT BITS

Insert bit hex holder adapter

| Model | Description | Ordering No. |
|----------|--------------------------------|--------------|
| H2-7/8 | Hex holder Sq Dr 3/4"-7/8" | 8434 2129 59 |
| H4-1/2 | Hex holder Sq Dr 1/2"-1/2" | 8434 2056 58 |
| H4-7/8 | Hex holder Sq Dr 1/2"-7/8" | 8434 2056 60 |
| H5-1 3/4 | Hex holder Sq Dr 1 1/2"-1 3/4" | 8434 2129 62 |
| H5-1-1/4 | Hex holder Sq Dr 1 1/2"-1 1/4" | 8434 2129 65 |
| H9-1 1/4 | Hex holder Sq Dr 1"-1 1/4" | 8434 2129 68 |
| H9-7/8 | Hex holder Sq Dr 1"-7/8" | 8434 2056 62 |



Insert bit with hex holder adapter

Insert bits

| Model | Description | Ordering No. | Model | Description | Ordering No. |
|----------|----------------|--------------|--------------|------------------|--------------|
| 7/8-10 | Hex size 10 mm | 8434 2054 24 | 1 3/4-46 | Hex size 46 mm | 8434 2050 44 |
| 7/8-12 | Hex size 12 mm | 8434 2054 26 | 1 3/4-50 | Hex size 50 mm | 8434 2050 46 |
| 7/8-14 | Hex size 14 mm | 8434 2054 30 | 7/8-1 | Hex size 1" | 8434 2054 20 |
| 7/8-17 | Hex size 17 mm | 8434 2054 32 | 1 1/4-1 | Hex size 1" | 8434 2050 12 |
| 7/8-19 | Hex size 19 mm | 8434 2054 34 | 1 1/4-1 1/16 | Hex size 1 1/16" | 8434 2124 10 |
| 7/8-22 | Hex size 22 mm | 8434 2054 36 | 1 1/4-1 1/4 | Hex size 1 1/4" | 8434 2050 14 |
| 7/8-24 | Hex size 24 mm | 8434 2054 38 | 1 1/4-1 1/8 | Hex size 1 1/8" | 8434 2050 16 |
| 7/8-27 | Hex size 27 mm | 8434 2123 32 | 1 3/4-1 1/2 | Hex size 1 1/2" | 8434 2050 32 |
| 1 1/4-24 | Hex size 24 mm | 8434 2050 18 | 1 3/4-1 3/4 | Hex size 1 3/4" | 8434 2050 34 |
| 1 1/4-27 | Hex size 27 mm | 8434 2050 20 | 1 3/4-1 3/8 | Hex size 1 3/8" | 8434 2050 36 |
| 1 1/4-28 | Hex size 28 mm | 8434 2050 22 | 1 3/4-1 5/8 | Hex size 1 5/8" | 8434 2050 38 |
| 1 1/4-29 | Hex size 29 mm | 8434 2050 24 | 7/8-1 12 PT | Hex size 1"-12pt | 8434 2126 86 |
| 1 1/4-30 | Hex size 30 mm | 8434 2050 26 | 7/8-1/2 | Hex size 1/2" | 8434 2054 22 |
| 1 1/4-32 | Hex size 32 mm | 8434 2050 28 | 7/8-13/16 | Hex size 13/16" | 8434 2054 28 |
| 1 1/4-33 | Hex size 33 mm | 8434 2050 30 | 7/8-3/4 | Hex size 3/4" | 8434 2054 40 |
| 1 1/4-36 | Hex size 36 mm | 8434 2124 13 | 7/8-5/8 | Hex size 5/8" | 8434 2054 42 |
| 1 3/4-36 | Hex size 36 mm | 8434 2050 40 | 7/8-7/8 | Hex size 7/8" | 8434 2054 44 |
| 1 3/4-40 | Hex size 40 mm | 8434 2124 16 | 7/8-9/16 | Hex size 9/16" | 8434 2054 46 |
| 1 3/4-41 | Hex size 41 mm | 8434 2050 42 | | | |

ALCO ARM

| Description | Ordering No. |
|-------------|--------------|
| RT0.5-ALC | 4222 2126 76 |
| RT01-ALC | 4222 2102 64 |
| RT03-ALC | 8434 2057 10 |
| RT05-ALC | 8434 2139 88 |
| RT08-ALC | 8434 2140 36 |
| RT10-ALC | 8434 2140 60 |

STEEL SLEEVE WITH FOOT

| Description | Ordering No. |
|-------------|--------------|
| RT01-SSLVF | 8434 2057 09 |
| RT03-SLVF | 4222 2130 21 |



ALCO arm

STEEL SLEEVE

| Description | Ordering No. |
|-------------|--------------|
| RT0.5-SSLV | 4222 2126 88 |
| RT01-SSLV | 8434 2057 08 |
| RT03-SSLV | 8434 2057 32 |
| RT05-SSLV | 8434 2140 30 |
| RT08-SSLV | 8434 2140 51 |
| RT10-SSLV | 8434 2140 90 |

CAM STYLE ARM

| Description | Ordering No. |
|--------------|--------------|
| RT03-CAM ARM | 4222 2130 12 |
| RT05-CAM ARM | 4222 2130 57 |



Steel sleeve with foot



Steel sleeve

EXTENDED REACTION ARM

| Description | Ordering No. |
|-------------|--------------|
| RT0.5-EXT | 4222 2126 82 |
| RT01-EXT | 8434 2056 92 |
| RT03-EXT | 8434 2057 12 |
| RT05-EXT | 8434 2057 34 |
| RT08-EXT | 8434 2140 42 |
| RT10-EXT | 8434 2140 66 |

SLIDING REACTION ARM

| Description | Ordering No. |
|-------------------|--------------|
| RT-01 SLIDING EXT | 8434 2057 33 |
| RT-01 SLIDING STD | 8434 2150 95 |
| RT-03 SLIDING EXT | 8434 2150 37 |
| RT-03 SLIDING STD | 8434 2150 30 |
| RT-05 SLIDING EXT | 8434 2150 36 |
| RT-05 SLIDING STD | 8434 2150 35 |
| RT-08 SLIDING EXT | 8434 2150 32 |
| RT-08 SLIDING STD | 8434 2150 31 |
| RT-10 SLIDING EXT | 8434 2150 34 |
| RT-10 SLIDING STD | 8434 2150 33 |
| RT20 SLIDING EXT | 8434 2150 90 |
| RT20 SLIDING STD | 8434 2150 89 |

STD= Standard EXT=Extended



CAM style arm



Extended reaction arm



Sliding reaction arm

Atlas Copco Low Profile Hydraulic Torque Wrenches eliminate problems with tight clearances. There are 6 models to choose from. Repeatability is +/- 1% and output accuracy is at +/- 3%.*

* As per NIST standards.



Low profile



| Model | Ratchet link hex size | | Torque range | | Weight | | Ordering No. |
|--------|-----------------------|---------------|--------------|------------|--------|------|--------------|
| | mm | in | Nm | ft lb | kg | lb | |
| RTX-2 | 19-65 | 3/4 – 2 3/4 | 346-2318 | 255-1710 | 2 | 4.5 | 8434 2021 90 |
| RTX-4 | 25-85 | 1 – 3 1/8 | 786-5226 | 580-3855 | 4.4 | 9.7 | 8434 2021 95 |
| RTX-8 | 46-105 | 1 5/8 – 4 1/8 | 1549-11049 | 1143-8151 | 9 | 19.5 | 8434 2022 00 |
| RTX-14 | 60-135 | 2 1/2 – 5 3/8 | 2725-18165 | 2010-13400 | 15 | 33 | 8434 2116 58 |
| RTX-18 | 75-140 | 3 1/2 – 5 1/2 | 3628-24191 | 2676-17845 | 23 | 51 | 8434 2022 05 |
| RTX-30 | 90-165 | 3 1/2 – 6 1/2 | 6466-43108 | 4770-31800 | 35.5 | 78 | 8434 2022 10 |

Dimensions

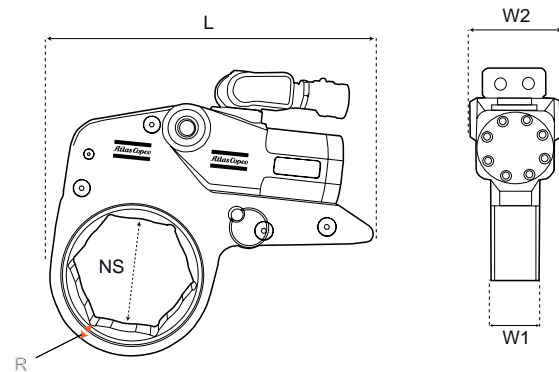

| Model | L | | NS (based on ratchet link size) | | R | | W1 | | W2 | |
|--------|-----|------|---------------------------------|-----------------|------|------|----|------|-----|------|
| | mm | in | mm | in | mm | in | mm | in | mm | in |
| RTX-2 | 183 | 7.2 | 19-65 | 3/4 – 2 9/16 | 9 | 0.35 | 32 | 1.26 | 49 | 1.92 |
| RTX-4 | 248 | 9.7 | 32-80 | 1 5/16 – 3 1/8 | 12 | 0.47 | 42 | 1.65 | 65 | 2.56 |
| RTX-8 | 308 | 12.1 | 46-100 | 1 13/16 – 3 7/8 | 15 | 0.59 | 53 | 2.08 | 82 | 3.22 |
| RTX-14 | 372 | 14.6 | 50-120 | 2 – 4 5/8 | 18.5 | 0.72 | 63 | 2.48 | 99 | 3.89 |
| RTX-18 | 393 | 15.5 | 75-140 | 3 – 5 1/2 | 22.2 | 0.87 | 70 | 2.75 | 111 | 4.37 |
| RTX-30 | 457 | 18 | 90-155 | 3 9/16 – 6 1/8 | 25.4 | 1 | 83 | 3.26 | 132 | 5.28 |

The following is a standard list of ratchet link sizes for use with RTX Powerheads. Whatever the link size, you still only need one torque chart per Powerhead model.



RTX-02 DIRECT FIT RATCHET LINK SIZES, TORQUE RANGE OF 346 – 2318 NM

| Across flat | | | | Across flat | | | | Across flat | | | |
|-------------|--------|--------------------|--------------|-------------|--------|------------------|--------------|-------------|--------|----------------|--------------|
| Imperial | Metric | Size | Ordering No. | Imperial | Metric | Size | Ordering No. | Imperial | Metric | Size | Ordering No. |
| | 17 | RL02-17MM | 8434 2132 41 | 1 | 34 | RL02-34 | 8434 2132 81 | 2" | 50.799 | RL02-200 RR | 8434 2021 74 |
| 3/4" | 19.05 | RL02-012/19MM RR | 8434 2132 47 | 1 3/8" | 34.924 | RL02-106 | 8434 2132 17 | 2 1/16" | 52.386 | RL02-201 | 8434 2132 53 |
| 3/4" | 19.05 | RL02-012/19MM | 8434 2131 84 | 1 7/16" | 36.511 | RL02-107/36MM | 8434 2021 68 | 2 1/8" | 53.974 | RL02-202 | 8434 2132 56 |
| 13/16" | 20.637 | RL02-013 | 8434 2131 87 | 1 7/16" | 36.511 | RL02-107/36MM RR | 8434 2021 83 | 2 3/16" | 55.561 | RL02-203/55MM | 8434 2132 59 |
| | 22 | RL02-22MM | 8434 2132 74 | 1 1/2" | 38 | RL02-108/38MM | 8434 2132 20 | 2 1/4" | 57.149 | RL02-204 | 8434 2132 62 |
| 7/8" | 22.224 | RL02-014 | 8434 2020 00 | 1 9/16" | 39.686 | RL02-109 | 8434 2132 23 | | 58 | RL02-58MM | 8434 2132 89 |
| 15/16" | 23.812 | RL02-015 | 8434 2131 90 | 1 5/8" | 41.274 | RL02-110/41MM | 8434 2021 07 | 2 5/16" | 58.736 | RL02-205 | 8434 2132 65 |
| | 24 | RL02-24MM | 8434 2020 54 | 1 5/8" | 41.274 | RL02-110/41MM RR | 8434 2021 08 | 2 3/8" | 60.324 | RL02-206/60MM | 8434 2021 47 |
| 1" | 25.339 | RL02-100/25MM | 8434 2020 03 | 1 11/16" | 43 | RL02-111/43MM | 8434 2132 26 | 2 7/16" | 61.911 | RL02-207 | 8434 2132 68 |
| 1" | 25.339 | RL02-100/25MM 12PT | 8434 2131 93 | 1 3/4" | 44.449 | RL02-112 | 8434 2132 29 | 2 1/2" | 63.498 | RL02-208 | 8434 2132 71 |
| 1 1/16" | 27 | RL02-101/27MM | 8434 2131 96 | 1 13/16" | 46 | RL02-113/46MM | 8434 2132 32 | 2 9/16" | 65 | RL02-209/65MM | 8434 2021 50 |
| 1 1/8" | 28.574 | RL02-102 | 8434 2131 99 | 1 13/16" | 46 | RL02-113/46MM RR | 8434 2132 35 | 2 5/8" | 66.673 | RL02-210 | 8434 2021 51 |
| 1 1/8" | 28.574 | RL02-102 12PT | 8434 2132 02 | 1 7/8" | 47.624 | RL02-114 | 8434 2020 06 | 2 3/4" | 69.848 | RL02-212 | 8434 2021 59 |
| 1 3/16" | 30.162 | RL02-103/30MM | 8434 2132 05 | 1 15/16" | 49.211 | RL02-115 | 8434 2132 38 | | 70 | RL02-212/70MM | 8434 2059 29 |
| 1 1/4" | 31.74 | RL02-104/32MM 12PT | 8434 2132 11 | | 50 | RL02-50MM | 8434 2021 86 | 2 13/16" | 71.436 | RL02-213 13/16 | 8434 2021 60 |
| | 32 | RL02-104/32MM | 8434 2132 08 | 2" | 50.799 | RL02-200 | 8434 2132 50 | 2 15/16" | 75 | RL02-215/75MM | 8434 2132 92 |
| 1 5/16" | 33.336 | RL02-105 | 8434 2132 14 | | | | | | | | |

RTX-04 DIRECT FIT RATCHET LINK SIZES, TORQUE RANGE OF 786 – 5226 NM

| Across flat | | | | Across flat | | | | Across flat | | | |
|-------------|--------|--------------------|--------------|-------------|--------|------------------|--------------|-------------|--------|------------------|--------------|
| Imperial | Metric | Size | Ordering No. | Imperial | Metric | Size | Ordering No. | Imperial | Metric | Size | Ordering No. |
| | 15 | RL04-15MM | 8434 2133 47 | 1 13/16" | 46 | RL04-113/46MM | 8434 2021 53 | 2 9/16" | 65 | RL04-209/65MM | 8434 2133 70 |
| | 17 | RL04-17MM | 8434 2133 48 | 1 13/16" | 46 | RL04-113/46MM RR | 8434 2116 01 | 2 5/8" | 66.673 | RL04-210 | 8434 2133 73 |
| 7/8" | 22.224 | RL04-014/22MM | 8434 2133 19 | 1 7/8" | 47.624 | RL04-114 | 8434 2133 43 | 2 11/16" | 68.261 | RL04-211 | 8434 2133 76 |
| | 24 | RL04-24MM | 8434 2133 93 | | 48 | RL04-48MM | 8434 2134 27 | 2 3/4" | 69.848 | RL04-212/70MM RR | 8434 2133 82 |
| 1" | 25.339 | RL04-100/25MM | 8434 2133 22 | 1 15/16" | 49.211 | RL04-115 | 8434 2133 46 | | 70 | RL04-212/70MM | 8434 2021 62 |
| 1 1/2" | 27 | RL04-101/27MM | 8434 2020 63 | | 50 | RL04-50MM | 8434 2134 30 | | 71 | RL04-71MM | 8434 2021 63 |
| 1 1/8" | 28.574 | RL04-102 | 8434 2133 23 | 2" | 50.799 | RL04-200 | 8434 2133 49 | 2 13/16" | 71.436 | RL04-213 | 8434 2133 85 |
| 1 3/16" | 30.162 | RL04-103/30MM | 8434 2133 25 | 2 1/16" | 52.386 | RL04-201 | 8434 2133 52 | 2 7/8" | 73.024 | RL04-214 | 8434 2133 88 |
| | 32 | RL04-104/32MM | 8434 2020 15 | 2 1/8" | 53.974 | RL04-202 | 8434 2133 55 | 2 15/16" | 75 | RL04-215/75MM | 8434 2020 21 |
| | 32 | RL04-104/32MM 12PT | 8434 2134 15 | | 54 | RL04-54MM | 8434 2134 33 | 3" | 76.199 | RL04-300 | 8434 2134 00 |
| 1 5/16" | 33.336 | RL04-105 | 8434 2133 32 | | 55 | RL04-55MM RR | 8434 2134 39 | | 77 | RL04-77MM | 8434 2020 22 |
| 1 3/8" | 34.924 | RL04-106 | 8434 2133 34 | 2 3/16" | 55.561 | RL04-203/55MM | 8434 2021 71 | 3 1/16" | 77.788 | RL04-301 | 8434 2134 03 |
| 1 7/16" | 36.511 | RL04-107/36MM | 8434 2020 09 | 2 1/4" | 57.149 | RL04-204 | 8434 2133 58 | 3 1/8" | 79.373 | RL04-302/79MM | 8434 2134 06 |
| 1 1/2" | 38 | RL04-108/38MM 12PT | 8434 2133 37 | | 58 | RL04-58MM | 8434 2134 42 | | 80 | RL04-80MM | 8434 2134 51 |
| 1 1/2" | 38 | RL04-108/38MM | 8434 2133 40 | 2 5/16" | 58.736 | RL04-205 | 8434 2133 61 | 3 3/16" | 80.96 | RL04-303 | 8434 2134 07 |
| 1 9/16" | 39.686 | RL04-109 | 8434 2133 41 | 2 3/8" | 60.324 | RL04-206/60MM | 8434 2133 64 | | 85 | RL04-85MM | 8434 2134 54 |
| 1 5/8" | 41.274 | RL04-110/41MM | 8434 2021 35 | 2 7/16" | 61.911 | RL04-207 | 8434 2133 65 | 3 3/8" | 85.725 | RL04-306 | 8434 2134 08 |
| | 42 | RL04-42MM | 8434 2134 24 | 2 1/2" | 63.498 | RL04-208 | 8434 2133 67 | 3 1/2" | 88.9 | RL04-308 | 8434 2134 09 |
| 1 11/16" | 43 | RL04-111/43MM | 8434 2020 12 | | 64 | RL04-64MM | 8434 2134 46 | 3 3/4" | 95 | RL04-312/95MM | 8434 2059 31 |
| 1 3/4" | 44.449 | RL04-112 | 8434 2020 60 | | | | | | | | |

RTX-08 DIRECT FIT RATCHET LINK SIZES, TORQUE RANGE OF 1549 – 11049 NM

| Across flat | | | | Across flat | | | | Across flat | | | |
|-------------|--------|--------------------|--------------|-------------|-----------|---------------|--------------|-------------|-----------|----------------|--------------|
| Imperial | Metric | Size | Ordering No. | Imperial | Metric | Size | Ordering No. | Imperial | Metric | Size | Ordering No. |
| 1 1/8" | 28.574 | RL08-102 | 8434 2134 93 | 63 | RL08-63MM | 8434 2020 31 | 3 5/16" | 84.138 | RL08-305 | 8434 2020 77 | |
| | 36 | RL08-36mm | 8434 2059 34 | 2 1/2" | 63.498 | RL08-208 | 8434 2135 26 | 85 | RL08-85MM | 8434 2021 11 | |
| 1 1/2" | 38 | RL08-108/38MM 12PT | 8434 2134 99 | 2 9/16" | 65 | RL08-209/65MM | 8434 2116 04 | 3 3/8" | 85.723 | RL08-306 | 8434 2021 02 |
| 1 5/8" | 41.274 | RL08-110/41MM | 8434 2135 02 | 2 5/8" | 66.673 | RL08-210 | 8434 2135 29 | 3 1/2" | 88.898 | RL08-308 | 8434 2020 74 |
| 1 11/16" | 43 | RL08-111/43MM | 8434 2135 08 | | 67 | RL08-67MM | 8434 2020 32 | 3 9/16" | 90.485 | RL08-309/90MM | 8434 2135 38 |
| 1 13/16" | 46 | RL08-113/46MM | 8434 2020 66 | | 70 | RL08-212/70MM | 8434 2135 59 | 3 5/8" | 92.075 | RL08-310 | 8434 2020 27 |
| 1 7/8" | 47.624 | RL08-114 | 8434 2135 11 | | 71 | RL08-71MM | 8434 2135 62 | 3 3/4" | 95 | RL08-312/95MM | 8434 2135 41 |
| | 50 | RL08-50MM | 8434 2135 47 | 2 13/16" | 71.436 | RL08-213 | 8434 2135 32 | 3 7/8" | 98.423 | RL08-314 | 8434 2021 65 |
| 2" | 50.799 | RL08-200 | 8434 2020 68 | | 75 | RL08-215/75MM | 8434 2135 65 | 1" | 100 | RL08-315/100MM | 8434 2020 24 |
| 2" | 50.799 | RL08-200 12PT | 8434 2020 67 | 3" | 76.199 | RL08-300 | 8434 2135 35 | 4" | 101.6 | RL08-400 | 8434 2135 44 |
| 2 1/16" | 52.386 | RL08-201 | 8434 2135 17 | | 77 | RL08-77MM | 8434 2135 68 | 4 1/16" | 103.18 | RL08-401 | 8434 2020 75 |
| | 54 | RL08-54MM | 8434 2135 50 | | 78 | RL08-78MM | 8434 2135 71 | | 105 | RL08-105MM | 8434 2134 96 |
| 2 3/16" | 55.561 | RL08-203/55MM | 8434 2020 69 | 3 1/8" | 79.373 | RL08-302 | 8434 2020 72 | 4 1/4" | 107.95 | RL08-404 | 8434 2020 78 |
| 2 1/4" | 57.149 | RL08-204 | 8434 2135 20 | | 80 | RL08-80MM | 8434 2135 74 | | 110 | RL08-110MM | 8434 2135 05 |
| 2 3/8" | 60.324 | RL08-206/60MM | 8434 2020 70 | 3 1/4" | 82.548 | RL08-304 | 8434 2020 73 | | 115 | RL08-115MM | 8434 2135 14 |
| 2 7/16" | 61.911 | RL08-207 | 8434 2135 23 | | | | | | | | |

RTX-14 DIRECT FIT RATCHET LINK SIZES, TORQUE RANGE OF 2725 – 18165 NM

| Across flat | | | | Across flat | | | | Across flat | | | |
|-------------|--------|---------------|--------------|-------------|-----------|---------------|--------------|-------------|----------|--------------|--------------|
| Imperial | Metric | Size | Ordering No. | Imperial | Metric | Size | Ordering No. | Imperial | Metric | Size | Ordering No. |
| 1 1/4" | 31.74 | RL14-104/32MM | 8434 2135 99 | 77 | RL14-77MM | 8434 2021 30 | 4" | 101.6 | RL14-400 | 8434 2136 43 | |
| 1 1/2" | 38 | RL14-108/38MM | 8434 2136 02 | 3 1/16" | 77.788 | RL14-301 | 8434 2136 28 | 4 1/16" | 103.18 | RL14-401 | 8434 2021 26 |
| 2" | 50.799 | RL14-200 | 8434 2020 33 | 3 1/8" | 79.373 | RL14-302 | 8434 2136 31 | 4 1/8" | 104.78 | RL14-402 | 8434 2136 46 |
| 2 3/16" | 55.561 | RL14-203/55MM | 8434 2020 36 | | 80 | RL14-80MM | 8434 2021 20 | | 105 | RL14-105MM | 8434 2135 98 |
| | 57 | RL14-57MM | 8434 2136 60 | 3 3/16" | 80.96 | RL14-303 | 8434 2136 32 | 4 3/16" | 106.36 | RL14-403 | 8434 2136 47 |
| 2 1/4" | 57.149 | RL14-204 | 8434 2020 37 | 3 1/4" | 82.548 | RL14-304 | 8434 2136 30 | 4 1/4" | 107.95 | RL14-404 | 8434 2020 84 |
| 2 3/8" | 60.324 | RL14-206/60MM | 8434 2136 13 | | 85 | RL14-85MM | 8434 2021 32 | 4 5/16" | 109.54 | RL14-405 | 8434 2020 83 |
| 2 1/2" | 63.498 | RL14-208 | 8434 2136 16 | 3 3/8" | 85.723 | RL14-306 | 8434 2136 33 | | 110 | RL14-110MM | 8434 2136 01 |
| 2 9/16" | 65 | RL14-209/65MM | 8434 2020 39 | 3 1/2" | 88.898 | RL14-308 | 8434 2136 34 | 4 1/2" | 114.3 | RL14-408 | 8434 2136 49 |
| 2 5/8" | 66.673 | RL14-210 | 8434 2136 19 | 3 9/16" | 90.485 | RL14-309/90MM | 8434 2136 37 | | 115 | RL14-115MM | 8434 2136 04 |
| | 67 | RL14-67MM | 8434 2136 64 | 3 5/8" | 92.075 | RL14-310 | 8434 2136 38 | 4 9/16" | 115.89 | RL14-409 | 8434 2136 52 |
| 2 11/16" | 68.261 | RL14-211 | 8434 2136 20 | 3 11/16" | 93.663 | RL14-311 | 8434 2136 39 | 4 5/8" | 117.48 | RL14-410 | 8434 2136 55 |
| | 70 | RL14-212/70MM | 8434 2136 66 | 3 3/4" | 95 | RL14-312/95MM | 8434 2020 42 | | 120 | RL14-120MM | 8434 2136 07 |
| | 71 | RL14-71MM | 8434 2136 67 | | 98 | RL14-98MM | 8434 2136 70 | 5" | 127 | RL14-500 | 8434 2021 41 |
| 2 13/16" | 71.436 | RL14-213 | 8434 2136 22 | 3 7/8" | 98.423 | RL14-314 | 8434 2020 45 | | 130 | RL14-130MM | 8434 2136 10 |
| | 75 | RL14-215/75MM | 8434 2021 29 | | 100 | RL14-100MM | 8434 2021 14 | 5 3/8" | 136.53 | RL14-506 | 8434 2136 58 |
| 3" | 76.199 | RL14-300 | 8434 2136 25 | | | | | | | | |

RTX-18 DIRECT FIT RATCHET LINK SIZES, TORQUE RANGE OF 3628 – 24191 NM

| Across flat | | | | Across flat | | | | Across flat | | | |
|-------------|--------|---------------|--------------|-------------|--------|----------------|--------------|-------------|--------|------------|--------------|
| Imperial | Metric | Size | Ordering No. | Imperial | Metric | Size | Ordering No. | Imperial | Metric | Size | Ordering No. |
| 1 5/16" | 33.336 | RL18-105 | 8434 2020 91 | 3 3/8" | 85.723 | RL18-306 | 8434 2020 85 | 4 5/8" | 117.47 | RL18-410 | 8434 2020 93 |
| 1 3/8" | 34.924 | RL18-106 | 8434 2020 92 | 3 1/2" | 88.898 | RL18-308 | 8434 2020 87 | | 120 | RL18-120MM | 8434 2137 00 |
| 2 3/16" | 55.561 | RL18-203/55MM | 8434 2137 10 | | 90 | RL18-90MM | 8434 2137 24 | 5" | 127 | RL18-500 | 8434 2021 56 |
| 2 3/8" | 60.324 | RL18-206/60MM | 8434 2137 11 | 3 9/16" | 90.485 | RL18-309/90MM | 8434 2020 86 | | 130 | RL18-130MM | 8434 2137 03 |
| 2 9/16" | 65 | RL18-209/65MM | 8434 2137 12 | 3 3/4" | 95 | RL18-312/95MM | 8434 2020 90 | | 135 | RL18-135MM | 8434 2137 06 |
| 2 3/4" | 69.85 | RL18-212/70MM | 8434 2059 47 | 3 7/8" | 98.423 | RL18-314 | 8434 2137 15 | 5 3/8" | 136.52 | RL18-506 | 8434 2021 23 |
| | 71 | RL18-71MM | 8434 2137 14 | | 100 | RL18-315/100MM | 8434 2020 88 | | 140 | RL18-140MM | 8434 2020 89 |
| | 75 | RL18-215/75MM | 8434 2137 16 | 4 1/16" | 103.18 | RL18-401 | 8434 2020 47 | 5 5/8" | 142.88 | RL18-510 | 8434 2021 22 |
| 3" | 76.199 | RL18-300 | 8434 2137 13 | | 105 | RL18-105MM | 8434 2136 88 | | 145 | RL18-145MM | 8434 2020 94 |
| | 77 | RL18-77MM | 8434 2137 17 | | 106 | RL18-106MM | 8434 2136 91 | 5 3/4" | 146.05 | RL18-512 | 8434 2020 96 |
| 3 1/8" | 79.373 | RL18-302 | 8434 2137 08 | 4 1/4" | 107.95 | RL18-404 | 8434 2020 48 | 5 15/16" | 150.81 | RL18-515 | 8434 2021 24 |
| | 80 | RL18-80MM | 8434 2137 18 | | 110 | RL18-110MM | 8434 2136 94 | | 151 | RL18-151MM | 8434 2137 09 |
| | 85 | RL18-85MM | 8434 2137 21 | | 115 | RL18-115MM | 8434 2136 97 | 6 1/8" | 155.58 | RL18-602 | 8434 2021 25 |

RTL-30 DIRECT FIT RATCHET LINK SIZES, TORQUE RANGE OF 6466 – 43108 NM

| Across flat | | | | Across flat | | | | Across flat | | | |
|-------------|---------|----------------|--------------|-------------|---------|------------|--------------|-------------|---------|------------|--------------|
| Imperial | Metric | Size | Ordering No. | Imperial | Metric | Size | Ordering No. | Imperial | Metric | Size | Ordering No. |
| 2 9/16" | 65 | RL30-209/65MM | 8434 2137 72 | 4 1/4" | 107.948 | RL30-404 | 8434 2137 90 | | 140 | RL30-140MM | 8434 2138 21 |
| 2 15/16" | 74.611 | RL30-215/75MM | 8434 2137 73 | | 110 | RL30-110MM | 8434 2137 39 | | 145 | RL30-145MM | 8434 2137 57 |
| 3 1/8" | 79.373 | RL30-302 | 8434 2137 75 | 4 1/2" | 114.3 | RL30-408 | 8434 2021 01 | 5 3/4" | 146.05 | RL30-512 | 8434 2137 93 |
| | 80 | RL30-80MM | 8434 2138 14 | | 115 | RL30-115MM | 8434 2137 42 | | 150 | RL30-150MM | 8434 2137 60 |
| | 85 | RL30-85MM | 8434 2138 17 | | 117 | RL30-117MM | 8434 2020 56 | 5 15/16" | 150.812 | RL30-515 | 8434 2137 96 |
| 3 3/8" | 85.723 | RL30-306 | 8434 2137 78 | 4 5/8" | 117.475 | RL30-410 | 8434 2021 00 | | 152 | RL30-152MM | 8434 2020 61 |
| 3 1/2" | 88.898 | RL30-308 | 8434 2137 81 | | 120 | RL30-120MM | 8434 2137 45 | 6" | 152.4 | RL30-600 | 8434 2138 02 |
| | 90 | RL30-90MM | 8434 2138 18 | | 123 | RL30-123MM | 8434 2137 48 | | 155 | RL30-155MM | 8434 2137 63 |
| 3 3/4" | 95 | RL30-312/95MM | 8434 2137 84 | | 124 | RL30-124MM | 8434 2020 55 | 6 1/8" | 155.575 | RL30-602 | 8434 2020 59 |
| | 98 | RL30-98MM | 8434 2138 20 | | 125 | RL30-125MM | 8434 2137 51 | | 160 | RL30-160MM | 8434 2137 66 |
| 3 7/8" | 98.423 | RL30-314 | 8434 2137 87 | 5" | 126.998 | RL30-500 | 8434 2020 99 | 6 3/8" | 161.925 | RL30-606 | 8434 2138 05 |
| | 100 | RL30-315/100MM | 8434 2137 33 | | 130 | RL30-130MM | 8434 2020 53 | 6 1/2" | 165.1 | RL30-608 | 8434 2138 08 |
| 4" | 101.6 | RL30-400 | 8434 2133 86 | | 133 | RL30-133MM | 8434 2020 58 | | 170 | RL30-170MM | 8434 2137 69 |
| 4 1/16" | 103.18 | RL30-401 | 8434 2137 88 | | 135 | RL30-135MM | 8434 2137 54 | | 175 | RL30-175MM | 8434 2138 22 |
| 4 1/8" | 104.775 | RL30-402 | 8434 2137 89 | 5 3/8" | 136.522 | RL30-506 | 8434 2020 51 | 7 1/16" | 179.387 | RL30-701 | 8434 2138 11 |
| | 105 | RL30-105MM | 8434 2137 36 | 5 1/2" | 139.7 | RL30-508 | 8434 2137 92 | | | | |



Insert hex

INSERT HEX, REDUCER FOR RATCHET LINKS

| Model | Starting size | Reduces to | Ordering No. | Model | Starting size | Reduces to | Ordering No. |
|-------------------|---------------|------------|--------------|---------------------|---------------|------------|--------------|
| RL02-INS-108/105 | 1 1/2 | 1 5/16 | 4222 2133 93 | RL04-INS-302/206 | 3 1/8 | 2 3/8 | 4222 2138 25 |
| RL02-INS-204/105 | 2 1/4 | 1 5/16 | 4222 2133 96 | RL04-INS-50/19 | 50 mm | 19 mm | 4222 2138 28 |
| RL02-INS-204/108 | 2 1/4 | 1 1/2 | 4222 2133 99 | RL04-INS-50/32 | 50 mm | 32 mm | 4222 2138 31 |
| RL02-INS-204/114 | 2 1/4 | 1 7/8 | 4222 2134 02 | RL04-INS-50/41 | 50 mm | 41 mm | 4222 2138 34 |
| RL02-INS-212/103 | 2 3/4 | 1 3/16 | 4222 2134 05 | RL04-INS-50/42 | 50 mm | 42 mm | 4222 2138 37 |
| RL02-INS-212/107 | 2 3/4 | 1 7/16 | 4222 2134 08 | RL04-INS-50/46 | 50 mm | 46 mm | 4222 2138 40 |
| RL02-INS-212/108 | 2 3/4 | 1 1/2 | 4222 2134 11 | RL04-INS-55/50 | 55 mm | 50 mm | 4222 2138 43 |
| RL02-INS-212/109 | 2 3/4 | 1 9/16 | 4222 2134 14 | RL04-INS-65/55 | 65 mm | 55 mm | 4222 2119 74 |
| RL02-INS-212/110 | 2 3/4 | 1 5/8 | 4222 2134 17 | RL04-INS-70/60 | 70 mm | 60 mm | 4222 2119 78 |
| RL02-INS-212/113 | 2 3/4 | 1 13/16 | 4222 2134 20 | RL04-INS-70/65 | 70 mm | 65 mm | 4222 2119 82 |
| RL02-INS-212/114 | 2 3/4 | 1 7/8 | 4222 2134 23 | RL08-INS-100MM/80MM | 100 mm | 80 mm | 4222 2140 62 |
| RL02-INS-46/36 | 46 mm | 36 mm | 4222 2134 26 | RL08-INS-203/200 | 2 3/16 | 2 | 4222 2140 65 |
| RL02-INS-50/41 | 50 mm | 41 mm | 4222 2134 29 | RL08-INS-302/215 | 3 1/8 | 2 15/16 | 4222 2140 68 |
| RL02-INS-50/46 | 50 mm | 46 mm | 4222 2134 32 | RL08-INS-302/50MM | 3 1/8 | 50 mm | 4222 2140 71 |
| RL04-INS-113/30MM | 1 13/16 | 30 mm | 4222 2119 58 | RL08-INS-302/55MM | 3 1/8 | 55 mm | 4222 2140 74 |
| RL04-INS-113/36MM | 1 13/16 | 36 mm | 4222 2119 62 | RL08-INS-302/60MM | 3 1/8 | 60 mm | 4222 2140 77 |
| RL04-INS-113/42MM | 1 13/16 | 42 mm | 4222 2119 66 | RL08-INS-314/308 | 3 7/8 | 3 1/2 | 4222 2140 80 |
| RL04-INS-200/112 | 2 | 1 3/4 | 4222 2137 74 | RL08-INS-60/50 | 60 mm | 50 mm | 4222 2122 07 |
| RL04-INS-200/113 | 2 | 1 13/16 | 4222 2137 77 | RL08-INS-60/55 | 60 mm | 55 mm | 4222 2122 11 |
| RL04-INS-204/105 | 2 1/4 | 1 5/16 | 4222 2137 80 | RL08-INS-70/46 | 70 mm | 46 mm | 4222 2140 83 |
| RL04-INS-204/108 | 2 1/4 | 1 1/2 | 4222 2137 83 | RL08-INS-70/55 | 70 mm | 55 mm | 4222 2140 86 |
| RL04-INS-204/114 | 2 1/4 | 1 7/8 | 4222 2137 86 | RL08-INS-70/65 | 70 mm | 65 mm | 4222 2140 89 |
| RL04-INS-208/114 | 2 1/2 | 1 7/8 | 4222 2119 70 | RL08-INS-80/50 | 80 mm | 50 mm | 4222 2140 92 |
| RL04-INS-212/ 208 | 2 3/4 | 2 1/2 | 4222 2137 89 | RL08-INS-80/55 | 80 mm | 55 mm | 4222 2140 95 |
| RL04-INS-212/201 | 2 3/4 | 2 1/16 | 4222 2137 92 | RL08-INS-80/65 | 80 mm | 65 mm | 4222 2140 98 |
| RL04-INS-212/202 | 2 3/4 | 2 1/8 | 4222 2137 95 | RL08-INS-80/75 | 80 mm | 75 mm | 4222 2141 01 |
| RL04-INS-212/203 | 2 3/4 | 2 3/16 | 4222 2137 98 | RL08-INS-95/80 | 95 mm | 80 mm | 4222 2141 04 |
| RL04-INS-212/204 | 2 3/4 | 2 1/4 | 4222 2138 01 | RL14-INS-314/308 | 3 7/8 | 3 1/2 | 4222 2143 38 |
| RL04-INS-212/206 | 2 3/4 | 2 3/8 | 4222 2138 04 | RL14-INS-410/314 | 4 5/8 | 3 7/8 | 4222 2143 41 |
| RL04-INS-215/209 | 2 15/16 | 2 9/16 | 4222 2138 07 | RL14-INS-410/404 | 4 5/8 | 4 1/4 | 4222 2143 44 |
| RL04-INS-302/100 | 3 1/8 | 1 | 4222 2138 10 | RL18-INS-135/123 | 135 mm | 123 mm | 4222 2144 13 |
| RL04-INS-302/108 | 3 1/8 | 1 1/2 | 4222 2138 13 | RL18-INS-151/143 | 151 mm | 143 mm | 4222 2144 16 |
| RL04-INS-302/110 | 3 1/8 | 1 5/8 | 4222 2138 16 | RL18-INS-410/308 | 4 5/8 | 3 1/2 | 4222 2144 19 |
| RL04-INS-302/112 | 3 1/8 | 1 3/4 | 4222 2138 19 | RL18-INS-410/312 | 4 5/8 | 3 3/4 | 4222 2144 22 |
| RL04-INS-302/200 | 3 1/8 | 2 | 4222 2138 22 | RL30-INS-602/600 | 6 1/8 | 6 | 4222 2145 48 |

ON SIDE REACTION ARM

| Model | Ordering No. |
|----------|--------------|
| RTX02-14 | 4222 2107 14 |
| RTX04-14 | 4222 2109 27 |
| RTX08-14 | 4222 2110 44 |
| RTX14-14 | 4222 2141 22 |
| RTX18-14 | 4222 2141 23 |
| RTX30-14 | 4222 2144 43 |

ALCO REACTION ARM

| Model | Ordering No. |
|-----------|--------------|
| RTX02-ALC | 8434 2057 58 |
| RTX04-ALC | 8434 2057 60 |
| RTX08-ALC | 8434 2057 62 |
| RTX14-ALC | 8434 2057 64 |
| RTX18-ALC | 8434 2057 66 |
| RTX30-ALC | 8434 2057 67 |



On side reaction arm



Alco reaction arm

BACKUP WRENCH

Atlas Copco Backup Wrenches works in conjunction with any Atlas Copco bolting tool and prevents the nut from rotating. The wrench is made of high strength steel and has a minimum of moving parts. This gives the tool a very long working lifetime without significant wear. Available in any nut size.



Backup wrench

| Model | Ordering No. | Model | Ordering No. |
|-----------------|--------------|----------------------|--------------|
| BK-206 | 8434 2056 36 | BK-500 | 8434 2056 54 |
| BK-113 | 8434 2056 30 | BK-105MM | 8434 2128 93 |
| BK-30MM | 8434 2129 26 | BK-202 | 8434 2129 14 |
| BK-200 | 8434 2056 32 | BK-43mm | 8434 2129 33 |
| BK-36MM | 8434 2129 32 | BK-404 | 8434 2129 38 |
| BK-110 | 8434 2056 28 | BK-013 13/16IN | 8434 2128 88 |
| BK-203 | 8434 2056 34 | BK-011 11/16IN | 8434 2128 89 |
| BK-209 | 8434 2056 38 | 3/4 IN BK-012 | 8434 2128 97 |
| BK-215 | 8434 2056 44 | 15/16IN BK-015 | 8434 2128 98 |
| BK-302 | 8434 2056 46 | BK-237 | 8434 2129 20 |
| BK-104=32MM | 8434 2128 90 | 1 1/8IN BK-102 | 8434 2129 55 |
| BK-308=90MM | 8434 2056 48 | 1 11/16IN BK-111 | 8434 2129 57 |
| BK-107 | 8434 2056 26 | 2 13/16IN BK-213 | 8434 2129 58 |
| BK-212 | 8434 2056 42 | 2 7/8IN BK-214 | 8434 2056 45 |
| BK-314 | 8434 2056 50 | BK-308=90MM | 8434 2056 51 |
| BK-312 | 8434 2129 29 | BK-506 | 8434 2056 56 |
| BK-210 | 8434 2056 40 | BK-55MM | 8434 2128 92 |
| BK-204 | 8434 2129 17 | BK-110MM | 8434 2128 99 |
| BK-100MM | 8434 2056 24 | BK-112 | 8434 2129 02 |
| BK-302=80MM | 8434 2056 53 | BK-120MM | 8434 2129 08 |
| BK-75MM | 8434 2056 55 | BK-101/27MM 101/27MM | 8434 2129 21 |
| BK-201 | 8434 2129 11 | BK-85MM | 8434 2129 44 |
| BK-24MM | 8434 2056 23 | 1 1/8IN BK-102 | 8434 2129 50 |
| BK-101 1-1/16IN | 8434 2056 29 | 1 11/16IN BK-111 | 8434 2129 51 |
| 1 5/16IN BK-105 | 8434 2056 31 | 2 13/16IN BK-213 | 8434 2129 52 |
| BK-34MM | 8434 2128 91 | BK-205 | 8434 2128 70 |
| 2 7/16IN BK-207 | 8434 2128 95 | BK-208 | 8434 2128 71 |
| BK-108 | 8434 2128 96 | BK-211 | 8434 2128 73 |
| BK-114 | 8434 2129 05 | BK-301 | 8434 2128 74 |
| BK-300 | 8434 2129 23 | BK-304 | 8434 2128 76 |
| BK-402 | 8434 2129 35 | BK-306 | 8434 2128 77 |
| BK-70MM | 8434 2129 41 | BK-310 | 8434 2128 67 |
| BK-014 7/8IN | 8434 2056 27 | BK-400 | 8434 2128 68 |
| BK-410 | 8434 2056 52 | | |

HYDRAULIC TORQUE WRENCH PUMPS

Atlas Copco Hydraulic Torque Wrench Pumps are designed for all hydraulic torque wrench applications. Our pumps are variable piston models with the smallest ratio weight/oil flow on the market.

The pumps are available in two versions: air driven, or electric driven, 110V or 220V. They come in three sizes: small, medium and large.



AIR DRIVEN HYDRAULIC TORQUE WRENCH PUMPS

| Model | Weight | | Oil capacity | | Intercooler system | Oil flow | | | | | | Ports | Ordering No. |
|--------------------------|--------|----|--------------|---------|--------------------|---------------------|-----|----------------------|-----|-----------------------|----|-------|--------------|
| | kg | lb | liters | gallons | | 86 bar/ 1250 psi | | 250 bar/ 3600 psi | | 700 bar/ 10000 psi | | | |
| Panther A110 Small frame | 15 | 33 | 1.89 | 0.5 | yes | 4.5 | 275 | 1.1 | 67 | 0.4 | 24 | 1 | 8434 2040 19 |
| Panther A110 Full frame | 15 | 33 | 1.89 | 0.5 | yes | 4.5 | 275 | 1.1 | 67 | 0.4 | 24 | 1 | 8434 2040 17 |
| Panther A380 | 22 | 48 | 5.67 | 1.5 | yes | 11.5 | 701 | 3.5 | 213 | 1.3 | 79 | 4 | 8434 2056 22 |
| TigAir | 34 | 75 | 9.5 | 2.5 | yes | - | - | - | - | 1.1 | 72 | 1 | 8434 2059 62 |

Dimensions

| Model | Length | | Width | | Height | |
|--------------------------|--------|--------|-------|--------|--------|--------|
| | mm | inches | mm | inches | mm | inches |
| Panther A110 Small frame | 340.3 | 13.4 | 347.9 | 13.7 | 419.1 | 16.5 |
| Panther A110 Full frame | 340.3 | 13.4 | 347.9 | 13.7 | 419.1 | 16.5 |
| Panther A380 | 398.7 | 15.7 | 378.4 | 14.9 | 459.7 | 18.1 |
| TigAir | 457.2 | 18 | 266.7 | 10.5 | 439.9 | 18.5 |

ELECTRIC DRIVEN HYDRAULIC TORQUE WRENCH PUMPS (100V / 220V)

| Model | Oil flow | | | | | | Ports | Ordering No. |
|----------------------------------|---------------------|-----|----------------------|-----|-----------------------|----|-------|--------------|
| | 86 bar/ 1250 psi | | 250 bar/ 3600 psi | | 700 bar/ 10000 psi | | | |
| Panther 025 with handle 110V | 3.2 | 195 | 0.9 | 54 | 0.35 | 21 | 1 | 8434 2040 31 |
| Panther 025 with full frame 110V | 3.2 | 195 | 0.9 | 54 | 0.35 | 21 | 1 | 8434 2040 33 |
| Panther 025 with handle 220V | 3.2 | 195 | 0.9 | 54 | 0.35 | 21 | 1 | 8434 2130 22 |
| Panther 025 with full frame 220V | 3.2 | 195 | 0.9 | 54 | 0.35 | 21 | 1 | 8434 2059 54 |
| Panther 055 110V | 6.4 | 391 | 1.8 | 110 | 0.7 | 42 | 4 | 8434 2040 35 |
| Panther 055 220V | 6.4 | 391 | 1.8 | 110 | 0.7 | 42 | 4 | 8434 2040 37 |
| Lynx 110V | - | - | - | - | 0.9 | 56 | 1 | 8434 2059 61 |
| Lynx 220V | - | - | - | - | 0.9 | 56 | 1 | 8434 2059 59 |
| Panther 150 110V | 10.5 | 641 | 2.5 | 153 | 1.5 | 92 | 4 | 8434 2040 39 |
| Panther 150 220V | 10.5 | 641 | 2.5 | 153 | 1.5 | 92 | 4 | 8434 2040 41 |

Accessories

Torque Wrenches

HOSES

Non-conductive, twin-line hoses are extremely safe, featuring a 4:1 safety ratio and safety hose burst guards. Batch numbers are printed directly on the hose for traceability.

- 700 bar / 10000 psi.
- Couplers and nipples included.

| Model | Description | Ordering No. |
|-----------|----------------|--------------|
| 90172 | 4.5 m / 15 ft | 8434 2050 08 |
| 090172-7 | 7 m / 22.9 ft | 8434 2123 95 |
| 090172-10 | 10 m / 32 ft | 8434 2123 74 |
| 090172-15 | 15 m / 49.2 ft | 8434 2050 10 |
| 090172-20 | 20 m / 65.6 ft | 8434 2123 83 |



Hose

CALIBRATED GAUGES

Our gauges are calibrated and have class 1 accuracy. An accurate pressure reading contributes to accurate torquing values.

| Model | Description | Ordering No. |
|----------|--------------------------|--------------|
| 090233-2 | Gauge 70Mpa back mounted | 8434 2124 07 |
| 090233-1 | Gauge 700 bar-10,000 psi | 8434 2051 59 |



Gauge

MANIFOLD KIT

| Model | Description | Ordering No. |
|-----------------|-------------|--------------|
| Lynx and TigAir | 4-port | 8434 2115 73 |

COUPLINGS

Couplings are available in standard or quick connect versions.

| Model | Description | Ordering No. |
|--------------|--------------------------------|--------------|
| 090156-1 | 1/8" Male coupler ^a | 8434 2050 06 |
| 90156 | 1/4" Male coupler ^b | 8434 2123 41 |
| 90157 | 3/8" Female coupler | 8434 2123 44 |
| 090155-1 | 1/8" Male nipple ^a | 8434 2123 65 |
| QC-COUPPLERS | Quick connect coupler set | 8434 2131 36 |
| 90101 | Nipple male-male 1/4INx1/4IN | 8434 2050 00 |
| 90103 | Nipple male 1/4INx1/8IN | 8434 2050 02 |
| 90135 | Nipple NPT 1/4INx1/4IN | 8434 2050 04 |
| 90155 | 1/4" Male female nipple | 8434 2123 38 |
| 090155-M | 1/4" Male nipple ^b | 8434 2123 68 |

^a Standard item on RT-0.5, RT-01, RTX-02

^b Standard item on all RT& RTX tools except RT-0.5, RT-01, RTX-02

HYDRAULIC OIL

Hydraulic oil for use in our high quality pumps. Comes in 5L (1.32G) container.

| Model | Description | Ordering No. |
|-----------|------------------------|--------------|
| Tellus 46 | 5 l / 1.32 g container | 8434 2040 45 |



Hydraulic oil

A woman with blonde hair tied back, wearing a light grey work shirt with blue and red accents, is focused on her work. She is using a black and orange power tool, likely a nutrunner, on a large industrial machine. The background shows a factory environment with shelves of components.

BATTERY ASSEMBLY TOOLS

Contents

| | |
|--|----|
| Introduction..... | 84 |
| BCP screwdriver, clutch type..... | 86 |
| BCV nutrunner, clutch type..... | 86 |
| Tensor STB nutrunner, transducerized type | 88 |
| Tensor SB nutrunner, transducerized type | 95 |

True cordless freedom

Atlas Copco's range of industrial battery assembly tools includes both shut-off and transducerized nutrunners and screwdrivers. They allow maximum freedom of movement along the line and inside narrow or closed compartments. Tensor STB tools also offer advanced process control.

The main advantage of battery tools is their superior flexibility due to the absence of cables. This, in turn, improves the efficiency of the operator. Battery assembly tools also contribute to improving safety in the workplace, since there are no air hoses or electric cables to become entangled or jammed. Also, in the automotive industry, for instance, there is no risk of scratches on the car body finish from air hoses or electric cables.

BCP – BCV BATTERY TOOLS - EXPERIENCE CORDLESS FREEDOM

The brushless BCP – BCV tools are ideal for quality critical applications where flexibility is essential. Final assembly of cars, offroad vehicles, buses, trucks, aircraft, motorcycles, engines, and white goods are just some examples of applications which can benefit from the performance and accessibility provided by the BCP - BCV tools. The slim, well-balanced design and ergonomic handle make it a pleasure to hold. Its compact size and Lithium-Ion batteries put it among the lightest battery tools on the market. BCP – BCV tools also offer variable speed and plenty of power, with torque levels ranging from 0.8 up to 45 Nm.

All these ergonomic features make the BCP - BCV the kind of tool you can work with all day long.

TENSOR STB NUTRUNNERS – FAST, LIGHT, TRANSDUCERIZED BATTERY TOOLS

Ergonomically designed Tensor STB pistol-grip (up to 12 Nm) and angle nutrunners (up to 150 Nm) are ideal for safety critical applications in cramped areas. No other battery powered tool can match Tensor STB's unique fastening performance and advanced process control.

Atlas Copco Industrial Radio Communication (IRC) enables the Tensor STB to be partnered with a Power Focus controller for accurate torque monitoring and full joint traceability. At a typical workstation, one Tensor STB tool can be used for several applications within the same torque range.

TENSOR SB NUTRUNNERS – TRANSDUCERIZED BATTERY TOOLS

The Tensor SB allows adjustable torque settings and has a transducer to ensure superior joint quality.

A robust metal housing ensures that the Tensor SB will stand up to tough industrial environments. Also the battery is powerful, reliable and has no memory effect, which means increased uptime for your production.



Powerful, durable and highly operator friendly

For quality critical applications where flexibility is essential, the BCP screwdriver and the BCV nutrunner are the ideal tool choices. Powerful and durable with superior ergonomics and operator feedback they offer higher productivity in assembly operations, independent of the industry.

FREEDOM – TRULY FLEXIBLE ASSEMBLY

- No product damage from cables or hoses
- No trip hazards from trailing cables
- No cable or hose management
- Speed setting functionality
- Reversible battery pack

ERGONOMICS – A PLEASURE TO WORK WITH

- Reduced operator fatigue and work related health problems
- Light, compact and well-balanced design
- Operator feedback

POWER – HIGH PERFORMANCE AND DURABILITY

- Robust and industrial tool design
- Li-Ion battery technology high power-to-weight.



BCPTOOL KEY FEATURES



BCVTOOL KEY FEATURES

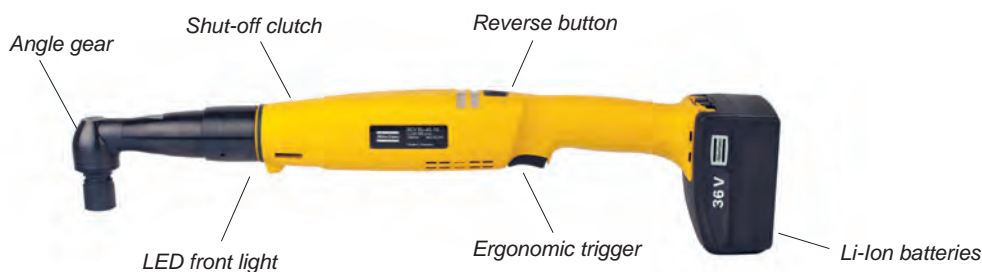

BCP screwdrivers offer true cordless freedom and superior ergonomics for the operator, thus contributing to outstanding performance.

- Ergonomic, lightweight pistol-grip design.
- 7 brushless models offering variable speed with a speed setting unit.
- Torque range: 0.8-12 Nm.
- Low speed models available.
- Two 18 V batteries: 2.1 Ah flat pack or 4.2 Ah regular pack.



| Model | Square drive in | Torque range | | Speed range r/min | Weight (excl. battery) | | Length mm | Height mm | Ordering No. |
|----------------|-----------------|--------------|---------|-------------------|------------------------|------|-----------|-----------|--------------|
| | | Nm | ft lb | | kg | lb | | | |
| BCP BL-2-I06 | 1/4 | 0.8-2.5 | 0.6-1.8 | 500-1550 | 0.86 | 1.89 | 200 | 188 | 8431 1273 00 |
| BCP BL-6-I06 | 1/4 | 2.0-6.0 | 1.5-4.4 | 300-1000 | 0.86 | 1.89 | 200 | 188 | 8431 1273 10 |
| BCP BL-8-I06 | 1/4 | 3.0-8.0 | 2.2-5.9 | 300-800 | 0.86 | 1.89 | 200 | 188 | 8431 1273 20 |
| BCP BL-12-I06 | 1/4 | 5.0-12.0 | 3.7-8.8 | 250-600 | 0.86 | 1.89 | 200 | 188 | 8431 1273 30 |
| BCP BL-2L-I06 | 1/4 | 0.8-2.5 | 0.6-1.8 | 150-440 | 0.86 | 1.89 | 200 | 188 | 8431 1273 50 |
| BCP BL-6L-I06 | 1/4 | 1.5-6.0 | 1.1-4.4 | 150-440 | 0.86 | 1.89 | 200 | 188 | 8431 1273 60 |
| BCP BL-12L-I06 | 1/4 | 3.0-12.0 | 2.2-8.8 | 150-440 | 0.86 | 1.89 | 200 | 188 | 8431 1273 40 |

-L stands for low speed models.

NOTE: The tools are set at maximum speed at delivery.

All pistol grip models have 1/4" female hexagon drive for bits with quick change chuck.

BCV nutrunners are durable and reliable and offer flexible assembly. A lightweight and handy tool for maximum operator comfort.

- Robust yet ergonomic angle tool.
- Torque range 1.5-45 Nm.
- There are 3 Li-Ion batteries, 18 V (2.1 and 4.2 Ah) and 36 V (2.1 Ah).



| Model | Square drive in | Torque range | | Free speed r/min | Weight (excl. battery) | | Power W | Battery V | Ordering No. |
|------------------|-----------------|--------------|------------|------------------|------------------------|-----|---------|-----------|--------------|
| | | Nm | ft lb | | kg | lb | | | |
| BCV BL-07L-06 | 1/4 | 1.5-7 | 1.1-5.16 | 120-360 | 1.15 | 2.6 | 340 | 18 | 8431 1275 07 |
| BCV BL-07-I06-QC | Hex 1/4 | 1.5-7 | 1.1-5.16 | 400-880 | 1.15 | 2.6 | 830 | 18 | 8431 1276 07 |
| BCV BL-15-06 | 1/4 | 5-15 | 3.68-11 | 200-480 | 1.15 | 2.6 | 970 | 18 | 8431 1275 15 |
| BCV BL-15-10 | 3/8 | 5-15 | 3.68-11 | 200-480 | 1.15 | 2.6 | 970 | 18 | 8431 1276 15 |
| BCV BL-30-10 | 3/8 | 10-30 | 7.37-22.12 | 100-300 | 1.55 | 3.4 | 1720 | 36 | 8431 1275 30 |
| BCV BL-45-10 | 3/8 | 20-45 | 14.7-33.2 | 50-180 | 1.65 | 3.6 | 1490 | 36 | 8431 1275 45 |

Optional Accessories

BATTERIES

| Model | Current V | Electric charge Ah | Weight | | Charge time min | Ordering No. |
|----------------------------|--------------|--------------------------|--------|------|--------------------|--------------|
| | | | kg | lb | | |
| Li-Ion flat pack | 18 | 2.1 | 0.37 | 0.82 | 35 | 4211 5526 82 |
| Li-Ion regular pack | 18 | 4.2 | 0.63 | 1.39 | 70 | 4211 5526 83 |
| Li-Ion (BCV 30/45 Nm only) | 36 | 2.1 | 0.60 | 1.32 | 70 | 4211 5526 87 |



Battery for BCV only

MULTICHARGER FOR BCV, BCP AND STB

| Model | Ordering No. |
|-------------------------------------|--------------|
| Multicharger 18V - 36V, all regions | 4211 5424 85 |



Battery Flat pack

COVER PROTECTIONS

| Model | Ordering No. |
|-------------------------------------|--------------|
| Battery cover protection, Flat pack | 4211 5601 00 |
| Battery cover protection, Big pack | 4211 5602 00 |
| BCV BL-30-10 protective cover | 4211 5603 30 |
| BCV BL-45-10 protective cover | 4211 5603 45 |
| BCV BL-07/15 protective cover | 4211 5603 00 |
| Tool cover protection (BCP only) | 4211 5415 00 |



Battery Big pack

MISCELLANEOUS

| Model | Ordering No. |
|-------------------------------------|--------------|
| Speed setting unit V2 (BCV and BCP) | 4211 5462 81 |
| Battery analyzer | 4211 5424 90 |
| Support handle | 4211 5421 80 |
| Suspension bail | 4211 5600 00 |
| Modular tool holder | 4220 3584 85 |

COLOUR RINGS

| Model | Ordering No. |
|--------|--------------|
| Red | 4211 5461 02 |
| Orange | 4211 5461 03 |
| Green | 4211 5461 04 |
| Blue | 4211 5461 05 |
| White | 4211 5461 06 |
| Purple | 4211 5461 07 |
| Grey | 4211 5461 08 |



Colour rings



Battery Multicharger 18V - 36V



Tool holder



Suspension bail



Battery cover Flat pack



Battery cover Big pack



Support handle



Speed setting unit



Tool cover

Cordless freedom with full process control

Tensor STB battery powered nutrunners offer the same benefits in terms of process control as Tensor ST nutrunners, yet with the freedom of cordless tools. The tools have the capability to communicate with Bluetooth or W-LAN together with a Power Focus controller, for full process control.

FLEXIBILITY – NO MORE CABLES

- No more cables and cable management
- No more damaged cables
- No product damage from cables
- No trip hazards from trailing cables

PRODUCTIVITY – SAVE TIME

- Increased operator efficiency
- Easy to set up and replace
- Eliminate need for multiple operations
- Faster than competing products

ERGONOMICS

- Reduced operator fatigue and work related health problems
- Unhindered access
- Low weight – up to 20 % lighter than competing products
- Compact size

STB TOOL KEY FEATURES

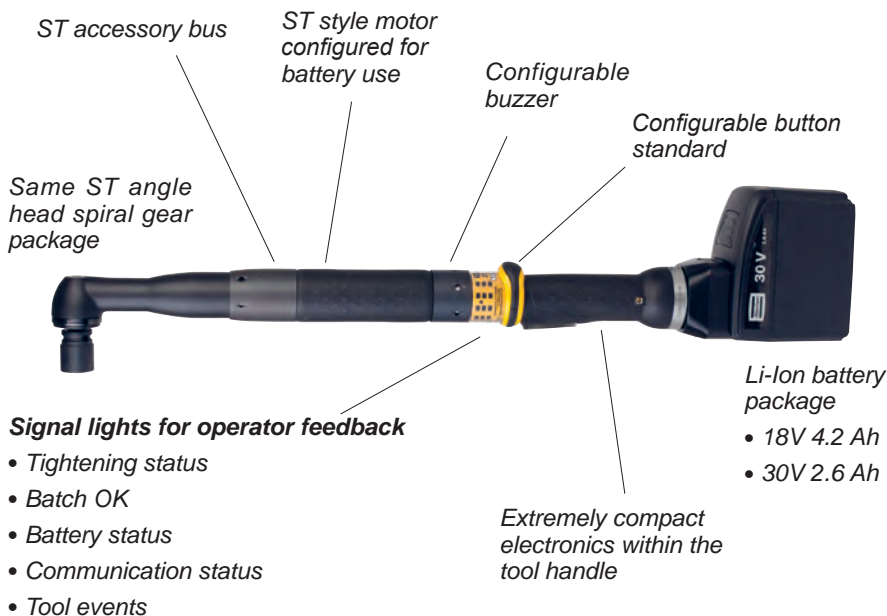

- State-of-the-art HMI with extensive functionality.
- Ergonomically designed tool, compact, lightweight, comfortable to work with.
- Durable housing for long service life-time.
- Excellent accessibility in cramped spaces.
- Bigger “foot” enables fast swap of battery.
- Integrated buffer battery maintains WiFi coverage for 30 seconds when battery is changed.
- New built-in external antenna gives superior communication reliability.



STB X4 tools are only compatible with Power Focus 6000 controllers

| Model | Square drive in | Torque range | | Battery | Speed r/min | Weight | | Weight incl. battery | | Length mm | Height mm | Ordering No. |
|-----------------------|-----------------|--------------|---------|---------|-------------|--------|------|----------------------|------|-----------|-----------|--------------|
| | | Nm | ft lb | | | kg | lb | kg | lb | | | |
| ETP STB34-06-106-BD-W | 1/4 | 2-6 | 2-4 | 18V | 750 | 1.15 | 2.5 | 1.75 | 3.86 | 216 | 240 | 8433 3019 75 |
| ETP STB34-06-10-BD-W | 3/8 | 2-6 | 2-4 | 18V | 750 | 1.15 | 2.5 | 1.75 | 3.86 | 216 | 240 | 8433 3019 25 |
| ETP STB34-12-106-BD-W | 1/4 | 4-12 | 3-9 | 18V | 750 | 1.15 | 2.5 | 1.75 | 3.86 | 216 | 240 | 8433 3019 95 |
| ETP STB34-12-10-BD-W | 3/8 | 4-12 | 3-9 | 18V | 750 | 1.15 | 2.5 | 1.75 | 3.86 | 216 | 240 | 8433 3019 97 |
| ETV STB34-15-10-BD-W | 3/8 | 4-15 | 3-11 | 18V | 720 | 1.7 | 3.7 | 2.35 | 5.2 | 435.4 | 59.7 | 8433 3019 15 |
| ETV STB34-30-10-BD-W | 3/8 | 6-30 | 4.5-22 | 30V | 380 | 1.7 | 3.7 | 2.35 | 5.2 | 470.8 | 60.5 | 8433 3019 35 |
| ETV STB64-50-10-BD-W | 3/8 | 15-50 | 10-37 | 30V | 365 | 2.15 | 4.7 | 3.1 | 6.8 | 507.8 | 66 | 8433 3019 65 |
| ETV STB64-70-13-BD-W | 1/2 | 15-70 | 10-50.7 | 30V | 265 | 2.65 | 5.84 | 3.6 | 7.9 | 519.6 | 76.7 | 8433 3019 55 |
| ETV STB64-100-13-BD-W | 1/2 | 20-100 | 15-72.5 | 30V | 170 | 3.1 | 6.8 | 4.05 | 8.9 | 556.7 | 79.1 | 8433 3019 85 |

Check with your local Atlas Copco representative regarding availability in your market.

Tensor STB offers genuine ergonomic and flexibility advantages for the operator which, in turn, raises operator efficiency.

- Low tool weight and high spindle speed reduce cycle time.
- Freedom of movement in all working positions.
- Lightweight components help reduce operator fatigue.
- Torque range ETV: 2-150 Nm.
- Torque range ETP: 2-12 Nm.
- Tensor STB-B is also available with ETO and ETC models.



| Model | Square drive in | Torque range | | Battery | Speed r/min | Weight | | Weight incl. battery | | Length mm | CS distance | Height mm | Ordering No. | With ball retainer Ordering No. |
|--|-----------------|--------------|---------|---------|-------------|--------|------|----------------------|------|-----------|-------------|-----------|--------------|---------------------------------|
| | | Nm | ft lb | | | kg | lb | kg | lb | | | | | |
| Right-angle standard models | | | | | | | | | | | | | | |
| ETV STB33-10-10-B | 3/8 | 2-10 | 2-7.5 | 18 V | 943 | 1.45 | 3.1 | 2.05 | 4.4 | 435.4 | 11 | 41 | 8433 3020 20 | 8433 3020 30 |
| ETV STB33-15-10-B | 3/8 | 4-15 | 3-11 | 18 V | 720 | 1.5 | 3.3 | 2.15 | 4.75 | 435.4 | 11 | 41 | 8433 3020 82 | 8433 3020 96 |
| ETV STB33-20-10-B | 3/8 | 5-20 | 4-14.5 | 18 V | 480 | 1.5 | 3.3 | 2.15 | 4.75 | 469.3 | 14 | 41.8 | 8433 3011 06 | 8433 3011 16 |
| ETV STB33-30-10-B | 3/8 | 6-30 | 4.5-22 | 18 V | 380 | 1.5 | 3.3 | 2.15 | 4.75 | 470.8 | 15.5 | 41.8 | 8433 3011 67 | 8433 3021 76 |
| ETV STB63-30-10-B | 3/8 | 6-30 | 4.5-22 | 30 V | 610 | 1.8 | 4 | 2.75 | 6.05 | 495.8 | 15.5 | 41.8 | 8433 3040 21 | — |
| ETV STB63-40-10-B | 3/8 | 12-40 | 9-29 | 30 V | 450 | 1.95 | 4.3 | 2.9 | 6.4 | 507.8 | 18 | 47.3 | 8433 3041 22 | 8433 3041 39 |
| ETV STB63-50-10-B | 3/8 | 15-50 | 10-37 | 30 V | 365 | 1.95 | 4.3 | 2.9 | 6.4 | 507.8 | 18 | 47.3 | 8433 3042 67 | 8433 3042 75 |
| ETV STB63-70-13-B | 1/2 | 15-70 | 10-50.7 | 30 V | 265 | 2.45 | 5.4 | 3.4 | 7.5 | 519.6 | 20 | 58 | 8433 3043 05 | 8433 3043 15 |
| ETV STB63-100-13-B | 1/2 | 20-100 | 15-72.5 | 30 V | 170 | 2.9 | 6.4 | 3.85 | 8.5 | 556.7 | 22.5 | 60.4 | 8433 3044 05 | 8433 3044 15 |
| ETV STB63-150-13-TM-B | 1/2 | 30-150 | 22-109 | 30 V | 72 | 3.4 | 7.5 | 4.35 | 9.6 | 522.9 | 23.5 | 98.1 | 8433 3045 05 | — |
| ETV STB63-150-13-W | 1/2 | 30-15 | 22-109 | 30V | 72 | 3.4 | 7.5 | 4.4 | 9.6 | 522.9 | 23.5 | 92.9 | 8433 3019 81 | — |
| Right-angle barcode reader models | | | | | | | | | | | | | | |
| ETV STB33-10-10-BCR-B | 3/8 | 2-10 | 2-7.5 | 18 V | 943 | 1.6 | 3.55 | 2.2 | 4.85 | 435.4 | 11 | 41 | 8433 3020 25 | 8433 3020 35 |
| ETV STB33-15-10-BCR-B | 3/8 | 4-15 | 3-11 | 18 V | 720 | 1.65 | 3.65 | 2.3 | 5.1 | 435.4 | 11 | 41 | 8433 3020 89 | — |
| ETV STB33-20-10-BCR-B | 3/8 | 5-20 | 4-14.5 | 18 V | 480 | 1.65 | 3.65 | 2.3 | 5.1 | 469.3 | 14 | 41.8 | 8433 3011 11 | — |
| ETV STB33-30-10-BCR-B | 3/8 | 6-30 | 4.5-22 | 18 V | 380 | 1.65 | 3.65 | 2.3 | 5.1 | 470.8 | 15.5 | 41.8 | 8433 3021 69 | — |
| ETV STB63-30-10-BCR-B | 3/8 | 6-30 | 4.5-22 | 30 V | 610 | 1.95 | 4.3 | 2.9 | 6.4 | 495.8 | 15.5 | 41.8 | 8433 3040 28 | 8433 3040 38 |
| ETV STB63-40-10-BCR-B | 3/8 | 12-40 | 9-29 | 30 V | 450 | 2.1 | 4.6 | 3.05 | 6.7 | 507.8 | 18 | 47.3 | 8433 3041 28 | 8433 3041 48 |
| ETV STB63-50-10-BCR-B | 3/8 | 15-50 | 10-37 | 30 V | 365 | 2.1 | 4.6 | 3.05 | 6.7 | 507.8 | 18 | 47.3 | 8433 3042 68 | 8433 3042 78 |
| ETV STB63-70-13-BCR-B | 1/2 | 15-70 | 10-50.7 | 30 V | 265 | 2.65 | 5.85 | 3.6 | 7.9 | 519.6 | 20 | 58 | 8433 3043 10 | 8433 3043 20 |
| ETV STB63-100-13-BCR-B | 1/2 | 20-100 | 15-72.5 | 30 V | 170 | 3.05 | 6.7 | 4 | 8.8 | 556.7 | 22.5 | 60.4 | 8433 3044 10 | 8433 3044 20 |
| Pistol-grip standard models | | | | | | | | | | | | | | |
| ETP STB33-06-10-B | 3/8 | 2-6 | 2-4 | 18 V | 1500 | 0.95 | 2.1 | 1.55 | 3.4 | 216 | — | 208 | 8433 3120 25 | — |
| ETP STB33-12-10-B | 3/8 | 4-12 | 3-9 | 18 V | 750 | 0.95 | 2.1 | 1.55 | 3.4 | 216 | — | 208 | 8433 3121 35 | — |
| Pistol-grip female hex models | | | | | | | | | | | | | | |
| ETP STB33-06-I06-B | 1/4 | 2-6 | 2-4 | 18 V | 1500 | 0.95 | 2.1 | 1.55 | 3.4 | 216 | — | 208 | 8433 3120 37 | — |
| ETP STB33-12-I06-B | 1/4 | 4-12 | 3-9 | 18 V | 750 | 0.95 | 2.1 | 1.55 | 3.4 | 216 | — | 208 | 8433 3121 48 | — |
| Pistol-grip barcode reader models | | | | | | | | | | | | | | |
| ETP STB33-06-10-BCR-B | 3/8 | 2-6 | 2-4 | 18 V | 1500 | 1.1 | 2.45 | 1.7 | 3.75 | 216 | — | 235 | 8433 3120 28 | — |
| ETP STB33-12-10-BCR-B | 3/8 | 4-12 | 3-9 | 18 V | 750 | 1.1 | 2.45 | 1.7 | 3.75 | 216 | — | 235 | 8433 3121 38 | — |
| Pistol-grip female hex with barcode reader models | | | | | | | | | | | | | | |
| ETP STB33-12-I06-BCR-B | 1/4 | 4-12 | 3-9 | 18 V | 750 | 1.1 | 2.45 | 1.7 | 3.75 | 216 | — | 235 | 8433 3121 58 | — |
| Pistol-grip with P-Set selector | | | | | | | | | | | | | | |
| ETP STB33-06-10-SEB | 3/8 | 2-6 | 2-4 | 18 V | 1500 | 1.1 | 2.45 | 1.7 | 3.75 | 216 | — | 235 | 8433 3121 61 | — |
| ETP STB33-12-10-SEB | 3/8 | 4-12 | 3-9 | 18 V | 750 | 1.1 | 2.45 | 1.7 | 3.75 | 216 | — | 235 | 8433 3121 63 | — |
| Pistol-grip female hex with P-Set selector | | | | | | | | | | | | | | |
| ETP STB33-06-I06-SEB | 1/4 | 2-6 | 2-4 | 18 V | 1500 | 1.1 | 2.45 | 1.7 | 3.75 | 216 | — | 235 | 8433 3121 65 | — |

Tensor STB offers genuine ergonomic and flexibility advantages for the operator which, in turn, raises operator efficiency.

- Low tool weight and high spindle speed reduce cycle time.
- Freedom of movement in all working positions.
- Lightweight components help reduce operator fatigue.
- Torque range ETV: 2-100 Nm.
- Torque range ETP: 2-12 Nm.
- Supports 2.4 and 5.0 Ghz.



| Model | Square drive | | Torque range | | Battery | Speed r/min | Weight | | Weight incl. battery | | Length mm | CS distance | Height mm | Ordering No. | With ball retainer Ordering No. |
|--|--------------|--------|--------------|------|---------|----------------|--------|------|-------------------------|-------|--------------|----------------|--------------|--------------|---------------------------------------|
| | in | Nm | ft lb | kg | | | lb | kg | lb | | | | | | |
| Right-angle standard models | | | | | | | | | | | | | | | |
| ETV STB33-10-10-W | 3/8 | 2-10 | 2-7.5 | 18 V | 943 | 1.45 | 3.1 | 2.05 | 4.4 | 435.4 | 11 | 41 | 8433 3019 00 | 8433 3019 04 | |
| ETV STB33-15-10-W | 3/8 | 4-15 | 3-11 | 18 V | 720 | 1.5 | 3.3 | 2.15 | 4.75 | 435.4 | 11 | 41 | 8433 3019 08 | 8433 3019 16 | |
| ETV STB33-20-10-W | 3/8 | 5-20 | 4-14.5 | 18 V | 480 | 1.5 | 3.3 | 2.15 | 4.75 | 469.3 | 14 | 41.8 | 8433 3019 20 | 8433 3019 24 | |
| ETV STB33-30-10-W | 3/8 | 6-30 | 4.5-22 | 18 V | 380 | 1.5 | 3.3 | 2.15 | 4.75 | 470.8 | 15.5 | 41.8 | 8433 3019 28 | 8433 3019 32 | |
| ETV STB63-30-10-W | 3/8 | 6-30 | 4.5-22 | 30 V | 610 | 1.8 | 4 | 2.75 | 6.05 | 495.8 | 15.5 | 41.8 | 8433 3019 42 | — | |
| ETV STB63-40-10-W | 3/8 | 12-40 | 9-29 | 30 V | 450 | 1.95 | 4.3 | 2.9 | 6.4 | 507.8 | 18 | 47.3 | 8433 3019 50 | 8433 3019 54 | |
| ETV STB63-50-10-W | 3/8 | 15-50 | 10-37 | 30 V | 365 | 1.95 | 4.3 | 2.9 | 6.4 | 507.8 | 18 | 47.3 | 8433 3019 58 | 8433 3019 62 | |
| ETV STB63-70-13-W | 1/2 | 15-70 | 10-50.7 | 30 V | 265 | 2.45 | 5.4 | 3.4 | 7.5 | 519.6 | 20 | 58 | 8433 3019 66 | 8433 3019 70 | |
| ETV STB63-100-13-W | 1/2 | 20-100 | 15-72.5 | 30 V | 170 | 2.9 | 6.4 | 3.85 | 8.5 | 556.7 | 22.5 | 60.4 | 8433 3019 74 | 8433 3019 78 | |
| Right-angle barcode reader models | | | | | | | | | | | | | | | |
| ETV STB33-15-B10-BCR-W | 3/8 | 4-15 | 3-11 | 18 V | 720 | 1.65 | 3.65 | 2.3 | 5.1 | 435.4 | 11 | 41 | — | 8433 3019 18 | |
| ETV STB33-20-10-BCR-W | 3/8 | 5-20 | 4-14.5 | 18 V | 480 | 1.65 | 3.65 | 2.3 | 5.1 | 469.3 | 14 | 41.8 | 8433 3019 22 | — | |
| ETV STB33-30-10-BCR-W | 3/8 | 6-30 | 4.5-22 | 18 V | 380 | 1.65 | 3.65 | 2.3 | 5.1 | 470.8 | 15.5 | 41.8 | 8433 3019 30 | 8433 3019 34 | |
| ETV STB63-30-10-BCR-W | 3/8 | 6-30 | 4.5-22 | 30 V | 610 | 1.8 | 4 | 2.75 | 6.05 | 495.8 | 15.5 | 41.8 | 8433 3019 44 | 8433 3019 48 | |
| ETV STB63-40-10-BCR-W | 3/8 | 12-40 | 9-29 | 30 V | 450 | 2.1 | 4.6 | 3.05 | 6.7 | 507.8 | 18 | 47.3 | 8433 3019 52 | — | |
| ETV STB63-50-10-BCR-W | 3/8 | 15-50 | 10-37 | 30 V | 365 | 2.1 | 4.6 | 3.05 | 6.7 | 507.8 | 18 | 47.3 | 8433 3019 60 | 8433 3019 64 | |
| ETV STB63-70-13-BCR-W | 1/2 | 15-70 | 10-50.7 | 30 V | 265 | 2.65 | 5.85 | 3.6 | 7.9 | 519.6 | 20 | 58 | 8433 3019 68 | 8433 3019 72 | |
| ETV STB63-100-13-BCR-W | 1/2 | 20-100 | 15-72.5 | 30 V | 170 | 3.05 | 6.7 | 4 | 8.8 | 556.7 | 22.5 | 60.4 | 8433 3019 76 | 8433 3019 80 | |
| Pistol-grip standard models | | | | | | | | | | | | | | | |
| ETP STB33-06-10-W | 3/8 | 2-6 | 2-4 | 18 V | 1500 | 0.95 | 2.1 | 1.55 | 3.4 | 216 | — | 208 | 8433 3019 82 | — | |
| ETP STB33-12-10-W | 3/8 | 4-12 | 3-9 | 18 V | 750 | 0.95 | 2.1 | 1.55 | 3.4 | 216 | — | 208 | 8433 3019 90 | — | |
| Pistol-grip female hex models | | | | | | | | | | | | | | | |
| ETP STB33-06-I06-W | 1/4 | 2-6 | 2-4 | 18 V | 1500 | 0.95 | 2.1 | 1.55 | 3.4 | 216 | — | 208 | 8433 3019 86 | — | |
| ETP STB33-12-I06-W | 1/4 | 4-12 | 3-9 | 18 V | 750 | 0.95 | 2.1 | 1.55 | 3.4 | 216 | — | 208 | 8433 3019 94 | — | |
| Pistol-grip barcode reader models | | | | | | | | | | | | | | | |
| ETP STB33-06-10-BCR-W | 3/8 | 2-6 | 2-4 | 18 V | 1500 | 1.1 | 2.45 | 1.7 | 3.75 | 216 | — | 235 | 8433 3019 84 | — | |
| ETP STB33-12-10-BCR-W | 3/8 | 4-12 | 3-9 | 18 V | 750 | 1.1 | 2.45 | 1.7 | 3.75 | 216 | — | 235 | 8433 3019 92 | — | |
| Pistol-grip female hex with barcode reader models | | | | | | | | | | | | | | | |
| ETP STB33-06-I06-BCR-W | 1/4 | 2-6 | 2-4 | 18 V | 1500 | 1.1 | 2.45 | 1.7 | 3.75 | 216 | — | 235 | 8433 3019 88 | — | |
| ETP STB33-12-I06-BCR-W | 1/4 | 4-12 | 3-9 | 18 V | 750 | 1.1 | 2.45 | 1.7 | 3.75 | 216 | — | 235 | 8433 3019 96 | — | |
| Pistol-grip with P-Set selector | | | | | | | | | | | | | | | |
| ETP STB33-06-10-SEW | 3/8 | 2-6 | 2-4 | 18 V | 1500 | 1.1 | 2.45 | 1.7 | 3.75 | 216 | — | 235 | 8433 3019 51 | — | |
| ETP STB33-12-10-SEL-W | 3/8 | 4-12 | 3-9 | 18 V | 750 | 1.1 | 2.45 | 1.7 | 3.75 | 216 | — | 235 | 8433 3019 91 | — | |
| Pistol-grip female hex with P-Set selector | | | | | | | | | | | | | | | |
| ETP STB33-06-I06-SEW | 1/4 | 2-6 | 2-4 | 18 V | 1500 | 1.1 | 2.45 | 1.7 | 3.75 | 216 | — | 235 | 8433 3019 53 | — | |
| ETP STB33-12-I06-SEW | 1/4 | 4-12 | 3-9 | 18 V | 750 | 1.1 | 2.45 | 1.7 | 3.75 | 216 | — | 235 | 8433 3019 57 | — | |
| Expanded memory models | | | | | | | | | | | | | | | |
| ETV STB33-10-B10-WXM | 3/8 | 2-10 | 2-7.5 | 18 V | 943 | 1.45 | 3.2 | 2.05 | 4.5 | 435.4 | 11 | 41 | 8433 3021 11 | — | |
| ETV STB33-30-B10-WXM | 3/8 | 6-30 | 4.5-22 | 18 V | 380 | 1.5 | 3.3 | 2.15 | 4.75 | 470.8 | 15.5 | 41.8 | 8433 3021 33 | — | |
| ETV STB63-30-B10-WXM | 3/8 | 6-30 | 4.5-22 | 30 V | 610 | 1.8 | 4 | 2.75 | 6.05 | 495.8 | 15.5 | 41.8 | 8433 3021 31 | — | |
| ETV STB63-40-B10-WXM | 3/8 | 12-40 | 9-29 | 30 V | 450 | 1.95 | 4.3 | 2.9 | 6.4 | 507.8 | 18 | 47.3 | 8433 3021 41 | — | |
| ETV STB63-50-B10-WXM | 3/8 | 15-50 | 10-37 | 30 V | 365 | 1.95 | 4.3 | 2.9 | 6.4 | 507.8 | 18 | 47.3 | 8433 3021 51 | — | |
| ETV STB63-70-B13-WXM | 1/2 | 15-70 | 10-50.7 | 30 V | 265 | 2.45 | 5.4 | 3.4 | 7.5 | 519.6 | 20 | 58 | 8433 3021 71 | — | |
| ETV STB63-100-B13-WXM | 1/2 | 20-100 | 15-72.5 | 30 V | 170 | 2.9 | 6.4 | 3.85 | 8.5 | 556.7 | 22.5 | 60.4 | 8433 3021 91 | — | |
| ETP STB33-06-10-WXM ^a | 3/8 | 2-6 | 2-4 | 18 V | 1500 | 0.95 | 2.1 | 1.55 | 3.4 | 216 | — | 208 | 8433 3021 03 | — | |
| ETP STB33-12-10-WXM ^a | 3/8 | 4-12 | 3-9 | 18 V | 750 | 1.1 | 2.45 | 1.7 | 3.75 | 216 | — | 235 | 8433 3021 13 | — | |

^a With Pset selector premounted.

IN-LINE CROWFOOT TOOLS

Dimensions

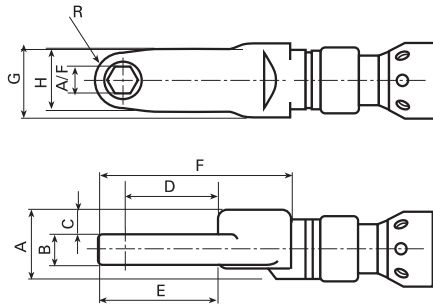

ETC STB

| Model | Torque range | | Speed r/min | Weight | | Length mm | A/F mm | A mm | B mm | C mm | D mm | E mm | F mm | G mm | H mm | R mm | Ordering No. |
|---------------------|--------------|-------|----------------|--------|-----|--------------|-----------|---------|---------|---------|---------|---------|---------|---------|---------|---------|--------------|
| | Nm | ft lb | | kg | lb | | | | | | | | | | | | |
| ETC STB63-18-10-LI3 | 4-18 | 3-13 | 470 | 2.7 | 5.9 | 646 | 10 | 34 | 15 | 12.5 | 36.7 | 59.2 | 82 | 35 | 22 | 10 | 8433 2316 04 |
| ETC STB63-20-12-LI3 | 6-23 | 4-17 | 226 | 2.7 | 5.9 | 676 | 12 | 34 | 10 | 15 | 51.9 | 54.3 | 102 | 35 | 31 | 14.5 | 8433 2316 10 |
| ETC STB63-28-12-LI3 | 7-28 | 5-20 | 226 | 2.7 | 5.9 | 647 | 12 | 34 | 15 | 12.5 | 45.5 | 71 | 94 | 35 | 30 | 13 | 8433 2316 07 |

OFFSET CROWFOOT TOOLS

Dimensions

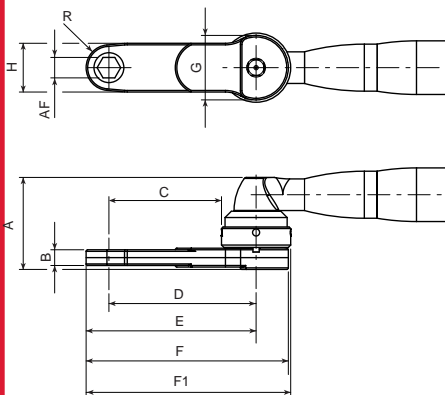

ETC STB

| Model | Torque range | | Speed r/min | Weight | | Length mm | A/F mm | A mm | B mm | C mm | D mm | E mm | F mm | G mm | H mm | R mm | F1 mm | Ordering No. |
|----------------------|--------------|-------|----------------|--------|-----|--------------|-----------|---------|---------|---------|---------|---------|---------|---------|---------|---------|----------|--------------|
| | Nm | ft lb | | kg | lb | | | | | | | | | | | | | |
| ETC STB63-18-10-LO3 | 5-18 | 4-13 | 610 | 2.3 | 5.1 | 564 | 10 | 60.3 | 15 | 14.6 | 32.8 | 42.8 | 57.8 | 36.5 | 22 | 10 | 61.1 | 8433 2315 02 |
| ETC STB63-20-13-LO5 | 5-23 | 4-17 | 610 | 2.6 | 5.7 | 657 | 13 | 58.5 | 10 | 71.6 | 93.6 | 108.1 | 128.6 | 44 | 31 | 14.5 | 130.1 | 8433 2315 08 |
| ETC STB63-28-12-LO5 | 6-28 | 5-20 | 465 | 2.9 | 6.4 | 656 | 12 | 69.5 | 15 | 62 | 84 | 97 | 117.5 | 44 | 30 | 13 | 119 | 8433 2315 05 |
| ETC STB63-40-14-LO3 | 8-44 | 6-32 | 375 | 2.8 | 6.2 | 620 | 14 | 69.5 | 18 | 24.8 | 46.8 | 61.3 | 81.8 | 44 | 31 | 14.5 | 83.3 | 8433 2315 11 |
| ETC STB63-40-3/8-LO3 | 8-40 | 6-29 | 375 | 3 | 6.6 | 609 | 3/8 | 90.3 | 36 | 18.2 | 40.2 | 50.5 | 71 | 44 | 29 | 10.3 | 72.5 | 8433 2315 17 |
| ETC STB63-50-16-LO3 | 12-64 | 8-47 | 265 | 3.4 | 7.5 | 635 | 16 | 78.3 | 24 | 27 | 51 | 66 | 88.5 | 48 | 30 | 15 | 90 | 8433 2315 20 |

IN-LINE TUBE NUT TOOLS

Dimensions

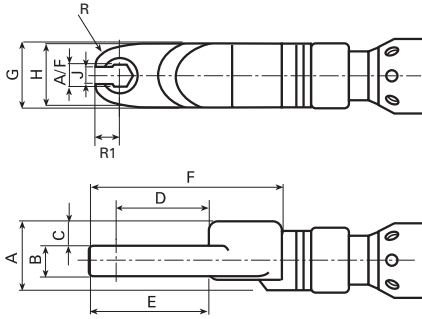

ETO STB

| Model | Torque range | | Speed r/min | Weight | | Length mm | A/F mm | A mm | B mm | C mm | D mm | E mm | F mm | G mm | H mm | J mm | R1 mm | R mm | Ordering No. |
|---------------------|--------------|-------|----------------|--------|-----|--------------|-----------|---------|---------|---------|---------|---------|---------|---------|---------|---------|----------|---------|--------------|
| | Nm | ft lb | | kg | lb | | | | | | | | | | | | | | |
| ETO STB63-8-8-LI3 | 3-8 | 2-6 | 945 | 2.6 | 5.7 | 622 | 8 | 32 | 11 | 12.3 | 22.7 | 21.6 | 60 | 33.5 | 29 | 6 | 7.8 | 10 | 8433 2316 46 |
| ETO STB63-12-8-LI3 | 4-12 | 3-9 | 723 | 2.6 | 5.7 | 628 | 8 | 32 | 10 | 13 | 27.3 | 25.4 | 66 | 33.5 | 31 | 7 | 9.8 | 11.5 | 8433 2316 49 |
| ETO STB63-15-10-LI3 | 4-15 | 3-11 | 589 | 2.6 | 5.7 | 629 | 10 | 32 | 12 | 11 | 27.9 | 26.1 | 68 | 33.5 | 32 | 8 | 10.3 | 14 | 8433 2316 55 |

OFFSET TUBE NUT TOOLS

Dimensions

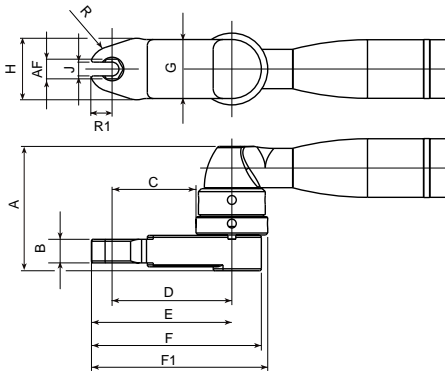

ETO STB

| Model | Torque range | | Speed r/min | Weight | | Length mm | A/F mm | A mm | B mm | C mm | D mm | E mm | F mm | G mm | H mm | J mm | R1 mm | R mm | F1 mm | Ordering No. |
|---------------------|--------------|-------|----------------|--------|-----|--------------|-----------|---------|---------|---------|---------|---------|---------|---------|---------|---------|----------|---------|----------|--------------|
| | Nm | ft lb | | kg | lb | | | | | | | | | | | | | | | |
| ETO STB33 | | | | | | | | | | | | | | | | | | | | |
| ETO STB33-12-10-LO5 | 3-12 | 2-9 | 480 | 2.3 | 5.1 | 596 | 10 | 62 | 10 | 42.7 | 60.9 | 70.7 | 85.7 | 36.5 | 31 | 7 | 9.8 | 11.5 | 89 | 8433 2315 59 |
| ETO STB33-15-10-LO3 | 4-14 | 3-10 | 480 | 2.3 | 5.1 | 560 | 10 | 63.3 | 12 | 7 | 25.1 | 34.9 | 49.9 | 36.5 | 31 | 7 | 9.8 | 11.5 | 53.2 | 8433 2315 56 |
| ETO STB63 | | | | | | | | | | | | | | | | | | | | |
| ETO STB63-18-12-LO5 | 4-18 | 3-13 | 610 | 2.6 | 5.7 | 634 | 12 | 62 | 11 | 51 | 73 | 84.9 | 105.4 | 44 | 38 | 8 | 11.9 | 15 | 107 | 8433 2315 68 |
| ETO STB63-20-12-LO3 | 5-20 | 3-15 | 610 | 2.4 | 5.3 | 589 | 12 | 64 | 14 | 7 | 29 | 40.2 | 60.7 | 44 | 38 | 8 | 11.2 | 14 | 62.2 | 8433 2315 65 |
| ETO STB63-30-13-LO5 | 10-33 | 7-24 | 265 | 3.8 | 8.4 | 647 | 13 | 72.5 | 18 | 53.3 | 75.3 | 87.7 | 108.2 | 44 | 40 | 10.4 | 12.4 | 25 | 109.7 | 8433 2315 74 |
| ETO STB63-28-13-LO3 | 6-28 | 4-21 | 465 | 2.8 | 6.2 | 611 | 13 | 65 | 11 | 12.8 | 36.8 | 51.8 | 74.3 | 48 | 50 | 10.4 | 15 | 31 | 75.8 | 8433 2315 77 |
| ETO STB63-40-17-LO5 | 10-50 | 7-37 | 265 | 3.6 | 7.9 | 675 | 17 | 80.5 | 18 | 66.8 | 90.8 | 105.8 | 128.3 | 48 | 50 | 12 | 15 | 31 | 129.8 | 8433 2315 80 |
| ETO STB63-50-17-LO3 | 11-60 | 8-44 | 265 | 3.6 | 7.9 | 628 | 17 | 77.8 | 18 | 11.1 | 42.4 | 59.6 | 85.6 | 62.5 | 59 | 14 | 17.2 | 32 | 90.9 | 8433 2315 83 |
| ETO STB63-50-21-LO3 | 11-55 | 8-40 | 265 | 3.6 | 7.9 | 638 | 21 | 73.8 | 12 | 18 | 49.2 | 69.3 | 96.8 | 62.5 | 59 | 16 | 20.1 | 32 | 100.6 | 8433 2315 86 |

Optional Accessories

CONTROLLER HARDWARE

| Model | Ordering No. |
|----------------------------------|--------------|
| Power Focus 4000 W 10 | |
| PF 4000-G-HW | 8433 7100 00 |
| PF 4000-C-HW | 8433 7100 05 |
| PF 4000-G-DN- HW | 8433 7140 00 |
| PF 4000-C-DN-HW | 8433 7140 05 |
| PF 4000-G-PB-HW | 8433 7142 00 |
| PF 4000-C-PB-HW | 8433 7142 05 |
| PF 4000-G-CC-HW | 8433 7143 00 |
| PF 4000-C-CC-HW | 8433 7143 05 |
| PF 4000-G-IB-HW | 8433 7145 00 |
| PF 4000-C-IB-HW | 8433 7145 05 |
| PF 4000-G-PN-HW | 8433 7148 00 |
| PF 4000-C-PN-HW | 8433 7148 05 |
| PF 4000-G-EIP-HW | 8433 7149 00 |
| PF 4000-C-EIP-HW | 8433 7149 05 |
| IRC Focus W 10 Bluetooth* | |
| IRC FOCUS-B-G-HW | 8433 6500 00 |
| IRC FOCUS-B-C-HW | 8433 6500 02 |
| IRC FOCUS-B-G-DN-HW | 8433 6500 04 |
| IRC FOCUS-B-C-DN-HW | 8433 6500 06 |
| IRC FOCUS-B-G-PB-HW | 8433 6500 12 |
| IRC FOCUS-B-C-PB-HW | 8433 6500 14 |
| IRC FOCUS-B-G-PN-HW | 8433 6500 24 |
| IRC FOCUS-B-C-PN-HW | 8433 6500 26 |
| IRC FOCUS-B-G-EIP-HW | 8433 6500 28 |
| IRC FOCUS-B-C-EIP-HW | 8433 6500 30 |

*) IRC Focus Communication kit is not needed. The IRC Focus is specially designed for the Tensor STB. The benefit is that the IRC Radio is integrated inside the IRC Focus. The IRC Focus has all the features of a Power Focus, with the exception that it cannot be used with cabled tools. IRC Focus is only available for Bluetooth tools.

TOOLSTALK PF

| No. of users | Ordering No. |
|---------------------------------|--------------|
| Basic version W 10 | |
| 1-user license | 8092 1190 01 |
| 5-user license | 8092 1190 05 |
| 10-user license | 8092 1190 10 |
| Plant license | 8092 1190 99 |
| Upgrade from W 7 to W 10 | |
| 1-user license | 8092 1190 31 |
| 5-user license | 8092 1190 35 |
| 10-user license | 8092 1190 40 |
| Plant license | 8092 1190 49 |

COM KIT

| | Ordering No. |
|------------------------------------|--------------|
| Com kit (minimum PF SW 7.5) | |
| Com kit IRC-B (Bluetooth) | 8433 3900 20 |
| Com kit IRC-W (W-LAN) | 8433 3900 35 |

NOTE: Kit includes: Serial port adapter, I/O cable, 3 m serial cable and power cable.

CONTROLLER SOFTWARE

| Controller software | Ordering No. |
|---------------------|--------------|
| RBU-Bronze | 8433 0010 10 |
| RBU-Silver | 8433 0015 20 |
| RBU-Gold | 8433 0020 20 |

MULTICHARGER

| Model | Ordering No. |
|-------------------------------------|--------------|
| Multicharger 18V - 36V, all regions | 4211 5424 85 |

BATTERY – LI-IO

| Voltage | Capacity | Weight kg | Ordering No. |
|---------|----------|-----------|--------------|
| 18 V | 4.2 Ah | 0.60 | 4211 5526 83 |
| 30 V | 2.6 Ah | 0.85 | 4211 5586 88 |

ACCESSORIES FOR IRC AND POWER FOCUS 4000 CONTROLLER

| | Ordering No. |
|-------------------------|--------------|
| Operator panel advanced | 8433 0565 00 |
| Stacklight ESL04 | 8433 0570 13 |
| Selector 4 | 8433 0610 04 |

TOOL ACCESSORIES

| | Ordering No. |
|--|--------------|
| ETV STB33 (10/15/20/30 Nm models) | |
| ETV STB63 (30/40/50 Nm models) | |
| Barcode scanner | 8433 0615 10 |
| Parameter set selector | 8433 0616 05 |
| I/O Device module | 8433 0617 12 |
| Adjustable headlights | 4220 3292 94 |
| Lever trigger 135 | 4220 3311 90 |
| Lever trigger on top | 4220 3186 90 |
| Front button | 4220 3184 90 |
| Scanner protective cover | 4220 2917 06 |
| ETV STB63 (70/100 Nm models) | |
| Barcode scanner | 8433 0615 20 |
| Parameter set selector | 8433 0616 15 |
| I/O Device module | 8433 0617 22 |
| Adjustable headlights | 4220 3292 95 |
| Lever trigger 135 | 4220 3311 91 |
| Lever trigger on top | 4220 3186 91 |
| Front button | 4220 3184 91 |
| ETP STB33 (06/12 Nm models) | |
| Barcode scanner | 4220 3507 90 |
| Parameter set selector | 4220 3507 81 |
| Scanner protective cover | 4220 2917 06 |



Stacklight ESL-04



Operator panel advanced



Selector 4



Tool holder



Lever trigger top



Lever trigger 135 deg.



Adjustable headlights



Front trigger button



Barcode scanner



Parameter set selector

Tensor SB-B

Nutrunners – Transducerized Type

Tensor SB is Atlas Copco's response to customers who demand a truly superior industrial battery nutrunner. This user-friendly tool is characterized by a combination of quality in every tightening, operator mobility and long-lasting durability. Together these advantages give Tensor SB a unique position on the market.

- Low tool weight and high spindle speed increases productivity.
- Durable metal housing.
- Freedom of working freely in any position.
- Torque range ETV: 2-140 Nm.
- Torque range ETP: 4-12 Nm.
- Connects through Bluetooth.



| Model | Square drive in | Torque range | | Battery | Free speed r/min | Weight | | Weight incl. battery | | Length mm | CS distance | Height mm | Ordering No. |
|-------------------|-----------------|--------------|----------|------------|------------------|--------|------|----------------------|------|-----------|-------------|-----------|--------------|
| | | Nm | ft lb | | | kg | lb | kg | lb | | | | |
| Angle | | | | | | | | | | | | | |
| ETV SB33-10-10-B | 3/8 | 2-10 | 2-7.5 | Li-Io 18 V | 975 | 1.3 | 2.9 | 1.9 | 4.2 | 455 | 14 | 42 | 8433 3031 20 |
| ETV SB33-15-10-B | 3/8 | 4-15 | 3-11 | Li-Io 18 V | 720 | 1.3 | 2.9 | 1.9 | 4.2 | 455 | 14 | 42 | 8433 3031 82 |
| ETV SB33-30-10-B | 3/8 | 6-30 | 4.5-22 | Li-Io 18 V | 380 | 1.6 | 3.55 | 2.2 | 4.85 | 471 | 15.5 | 42 | 8433 3031 66 |
| ETV SB63-40-10-B | 3/8 | 12-40 | 9-29 | Li-Io 30 V | 450 | 1.85 | 4.1 | 2.8 | 6.15 | 508 | 18 | 47.5 | 8433 3031 23 |
| ETV SB63-50-10-B | 3/8 | 15-50 | 10-37 | Li-Io 30 V | 360 | 1.85 | 4.1 | 2.8 | 6.15 | 508 | 18 | 47.5 | 8433 3031 67 |
| ETV SB63-70-13-B | 1/2 | 15-70 | 10-50.7 | Li-Io 30 V | 265 | 2.9 | 6.4 | 3.85 | 8.45 | 533 | 20 | 58 | 8433 3031 05 |
| ETV SB63-100-13-B | 1/2 | 20-100 | 15-72.5 | Li-Io 30 V | 170 | 3 | 6.6 | 3.95 | 8.7 | 557 | 22.5 | 60.5 | 8433 3031 10 |
| ETV SB63-140-13-B | 1/2 | 20-140 | 15-101.5 | Li-Io 30 V | 120 | 3.4 | 7.5 | 4.4 | 9.7 | 593 | 25 | 65 | 8433 3031 15 |
| Pistol | | | | | | | | | | | | | |
| ETP SB33-12-I06-B | 1/4 | 4-12 | 3-9 | Li-Io 18 V | 750 | 0.95 | 2.1 | 1.6 | 3.55 | 216 | — | 208 | 8433 3031 49 |

Optional Accessories

CONTROLLER HARDWARE

| Model | Ordering No. |
|----------------------------------|--------------|
| Power Focus 4000 W 10 | |
| PF 4000-G-HW | 8433 7100 00 |
| PF 4000-C-HW | 8433 7100 05 |
| IRC Focus W 07 Bluetooth* | |
| IRC FOCUS-B-G-HW | 8433 6500 00 |
| IRC FOCUS-B-C-HW | 8433 6500 02 |

*) IRC Focus Communication kit is not needed.

CONTROLLER SOFTWARE

| Controller software | Ordering No. |
|---------------------|--------------|
| RBU SB | 8433 0081 00 |

TOOLSTALK POWER FOCUS

| No. of users | Ordering No. |
|---------------------------|--------------|
| Basic version W 10 | |
| 1-user license | 8092 1190 01 |

COM KIT

| | Ordering No. |
|------------------------------------|--------------|
| Com kit (minimum PF SW 7.5) | |
| Com kit IRC-B (Bluetooth) | 8433 3900 20 |

NOTE: Kit includes: Serial port adapter, I/O cable, 3 m serial cable and power cable.

BATTERY – LI-IO

| Voltage | Capacity | Weight kg | Ordering No. |
|---------|----------|-----------|--------------|
| 18 V | 4.2 Ah | 0.60 | 4211 5526 83 |
| 30 V | 2.6 Ah | 0.85 | 4211 5586 88 |

MULTICHARGER

| Model | Ordering No. |
|-------------------------------------|--------------|
| Multicharger 18V - 36V, all regions | 4211 5424 85 |



Battery Big pack



Battery multicharger 18V - 36V

A person is using a black electric screwdriver to work on a complex mechanical assembly, likely an aircraft engine. The background shows various pipes, wires, and metal components in a workshop setting.

ELECTRIC ASSEMBLY TOOLS AND SYSTEMS

Contents

| | | | |
|---------------------|-----|------------------------------------|-----|
| Introduction..... | 97 | Tensor DS | 118 |
| Product safety..... | 98 | Tensor ST..... | 121 |
| Screwdrivers..... | 99 | Tensor STR | 128 |
| EBL..... | 100 | Tensor SR | 130 |
| MicroTorque | 102 | Controllers and software..... | 139 |
| Tensor ES..... | 108 | Power Focus 600 / 6000 | 140 |
| Tensor DL..... | 109 | DS/DL drive | 143 |
| Tensor SL | 110 | Power Focus 4000 | 144 |
| Tensor SR | 111 | Programming software | 146 |
| Nutrunners..... | 115 | Quality Integrated Fastening | 147 |
| Tensor ES..... | 117 | Station hardware | 149 |
| | | Station software | 151 |

Highest productivity with lowest life-cycle cost

Atlas Copco supplies a comprehensive range of high productivity assembly tools with intelligent controllers and a sharp focus on ergonomics. Our many product lines were developed to meet all your tightening needs and give you lowest life-cycle cost. Products range from low torque MicroTorque tools providing 0.5 Ncm of torque, to high torque Tensor ST tools, offering up to 4,000 Nm.

EBL SCREWDRIVER

Low voltage, brushless screwdriver for demanding applications, with shut-off clutch for high fastening precision, time after time.

MICROTORQUE LOWTORQUE SCREWDRIVER

Low torque intelligent screwdrivers that ensure joint integrity in high volume consumer applications and high value critical products.

POWER FOCUS 4000 CONTROLLER

The Power Focus is the market-leading controller for handheld tools and has the capability to run fixtured tools. Power Focus is a modular range of controllers with full flexibility and connectivity to fit your production infrastructure. The Power Focus 4000 controls tools in the Tensor ST, STB, DS, SL and ETX family. The Power Focus 4002 controls Tensor SL tools.

POWER FOCUS 600 CONTROLLER

The Power Focus 600 is compatible with the Tensor ES tools and is the perfect choice for quality critical assembly. It comes in one single hardware version regardless of which tool model or functionality level is used. Its powerful industrial design gives a reliable process that will speed up your tightening operations.

DS/DL CONTROLLER

The DS/DL system offers a quick and easy route to improved process monitoring in your assembly operations. With a range of alternative drives, you can choose the functionality best suited for your operations. The DL drive runs Tensor DL tools and is available as Basic or Advanced models.

TENSOR TOOLS

The Tensor tool range covers all assembly requirements for safety critical and quality critical applications.

Tensor ES: Quality critical applications with high demands on productivity, ergonomics and error proofing.

Tensor SL: Safety-critical low torque tools for small screw applications. It offers compact screwdriver ergonomics with traceability and error proofing capability.

Tensor ST: The second generation of Tensor tools was developed with the focus on reducing tool weight and increasing productivity. Tensor ST has an internal bus connection for intelligent accessories such as a barcode reader and P-selector switch.

Tensor STR, SR: The latest generation of Tensor tools where ergonomics and productivity are taken to a new level.

Tensor DS: Quality critical applications where demands on accuracy and ergonomics are high.

Tensor DL: Quality critical applications with high demands on quality assurance.

Tensor STB: The battery version of Tensor ST for safety critical applications.



Product Safety

SAFETY GUIDELINES

At Atlas Copco we want you to operate our tools safely. Always read and follow all operating and safety instructions, and comply with local safety regulations. There is a range of accessories for Atlas Copco tools. They are intended to reduce the risk of injury during certain assembly processes.

HOW TO MAKE TOOL OPERATION SAFER

1 Entanglement hazard

- Hands and other objects (long hair, necklaces etc.) can get entangled with the rotating drive, causing severed or broken fingers.
- Do not use gloves.
- Never hold the drive, socket or extension with your hands.

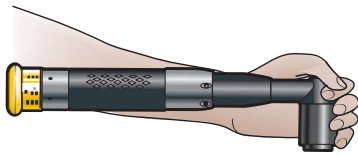

5 Reaction bar

- When a reaction bar is used, keep hands away from the reaction bar while tightening a joint, otherwise hands may get squeezed.



2 Hold the tool correctly

- Keep hands and other objects (long hair, necklace, etc.) away from the rotating drive, socket or extension.
- Hold the tool correctly with one hand on the handle of the tool and the other hand on the top of the angle head.

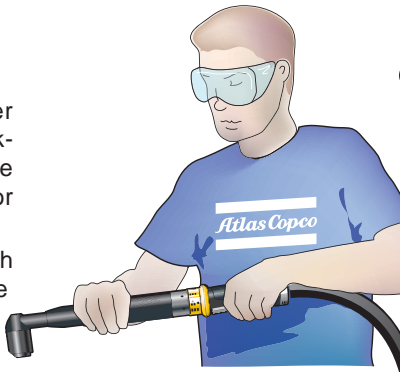

6 Open end tools

- Never put your finger into the open end of a tool, even if a dual action trigger is used.
- To avoid accidents, to activate the tool, both triggers must be pressed within 500 ms.

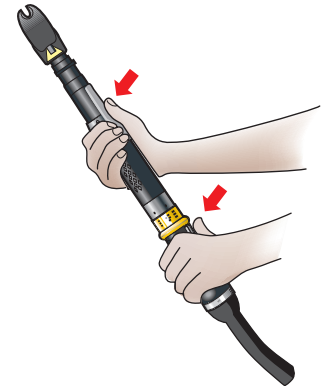

3 Supported extensions

- If you use an extension, never hold the extension with your hand while it is rotating. If you need to guide the extension, in order to locate the socket quickly and accurately, use an accessory to reduce the risk of entanglement.

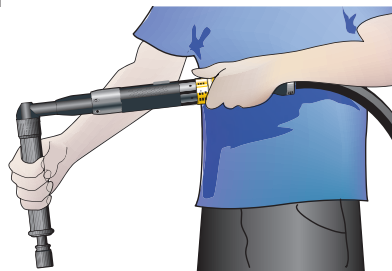

Other advantages are:

- Longer life for angle gear.
- More uniform tightening results.

7 Angle nutrunners with reaction bar

- Use reaction bar at high torque. For soft joints, a reaction bar should be used at >60 Nm.

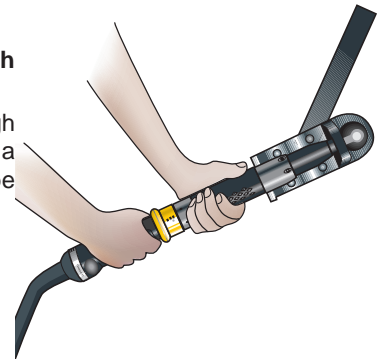

4 Use goggles

- Always use approved safety goggles to protect your eyes from objects that might accidentally fly into your face.

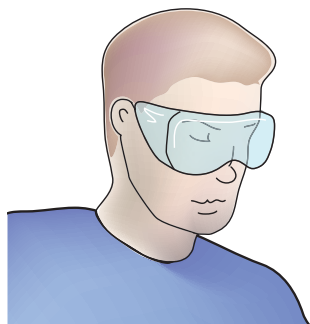

8 Screwdrivers

- Consider using a support handle or support arms, particularly for straight versions and for torques of 6 Nm and upwards.



If you're looking for quality, you've found it

Atlas Copco supplies a complete range of advanced electric screwdrivers to match your needs. If it's cutting-edge ergonomics you want, true reliability, or long-life, low maintenance motors, we have them. Models range from EBL and MicroTorque low-torque tools up to Tensor tools with torques of up to 20 Nm. They all have one thing in common – quality.

EBL SCREWDRIVERS

EBL screwdrivers are the best in class clutch electric screwdriver for low torque applications, its brushless motor combined with the high accuracy, delivers the best tightening solution for any assembly process.

MICROTORQUE

Microtorque screwdriver range is the most advanced and intelligent tightening solution for any low torque application. Extremely ergonomic, very compact and full of functionalities it is the right tool to boost productivity and quality, resulting in high efficiency and cost reduction.

TENSOR SR TOOLS

ESD certified, Tensor SR angle tools are fast, compact and easy to operate. They feature an easy-to-configure function button and front LED's for clear operator feedback.

With a push-to-start mechanism and an integrated front guide light, STR straight tools are suitable for both hand-held and fixtured applications

TENSOR DL

Optimized for small screw assembly, Tensor DL non-transducerized screwdrivers are available in straight, right angle and pistol grip versions. There are also Tensor DL straight screwdrivers for fixtured applications. All models have good ergonomic designs and brushless motors offering low maintenance costs.

TENSOR SL

Tensor SL transducerized screwdrivers are available in straight, right angle and pistol grip versions, with a straight model for fixtured applications that is very light and compact. All the tools offer high power-to-weight ratios, good ergonomic designs and clear operator feedback via LED's lights and buzzers (depending on the model).

TENSOR ES

Tensor ES transducerized screwdrivers for quality critical applications are available in straight and right angle versions. All models have a sealed design for robustness and offer high productivity with improved ergonomics.



ESD CERTIFIED SCREWDRIVERS

Atlas Copco offers ESD certified tools in the standard range of screwdriver models most frequently used in the electronics industries. ESD certification means a guarantee against damage of electronic components by an uncontrolled electrostatic discharge (ESD) from the tools.

Conformity to the requirements of IEC 61340-5-1 standard proposal is approved by SP, the Swedish National Testing and Research Institute. In practice it certifies that at no point will the material of the equipment hold an electrostatic potential above 100 V for more than 2 seconds.

DESIGNED FOR LOW-TORQUE ASSEMBLY OPERATIONS

Featuring superior ergonomics and the latest technology, Atlas Copco's EBL screwdriver is setting new standards for electric low-torque screwdrivers.

- Brushless motor provides long working life, extended service intervals and low maintenance requirements.
- Good ergonomics mean maximum operator comfort: comfortable grip, low tool weight and lower noise level due to the brushless motor.
- Reporting tool models have a batch count feature that ensures that all screws have been tightened.
- Soft-stop feature on certain models prevents damage to sensitive electronics and plastic assembly components.



| Model | Screw capacity | Torque range soft joint | | Free speed r/min | Weight | | Length mm | Bit drive | Ordering No. |
|-----------------------------------|----------------|-------------------------|----------|------------------|--------|-----|-----------|----------------|--------------|
| | | Nm | in lb | | kg | lb | | | |
| Standard models | | | | | | | | | |
| EBL03 | M1-2 | 0.05-0.3 | 0.4-2.7 | 870 | 0.3 | 0.7 | 185 | Wing type 4 mm | 8431 0170 02 |
| EBL03-Q | M1-2 | 0.05-0.3 | 0.4-2.7 | 870 | 0.3 | 0.7 | 185 | 1/4" Hex | 8431 0170 04 |
| EBL12 | M2-3 | 0.2-1.2 | 1.8-10.6 | 910 | 0.5 | 1.1 | 215 | 1/4" Hex | 8431 0170 11 |
| EBL12-1500 | M2-3 | 0.2-1.2 | 1.8-10.6 | 1500 | 0.5 | 1.1 | 215 | 1/4" Hex | 8431 0170 41 |
| EBL20 | M2-3 | 0.5-2.0 | 4.5-18 | 750 | 0.5 | 1.1 | 215 | 1/4" Hex | 8431 0170 16 |
| EBL21-1500 | M2-3 | 0.5-2.1 | 4.5-19 | 1500 | 0.8 | 1.8 | 235 | 1/4" Hex | 8431 0170 43 |
| EBL25 | M2.5-4 | 1.0-2.5 | 8.8-22.1 | 930 | 0.8 | 1.8 | 235 | 1/4" Hex | 8431 0170 23 |
| EBL25-1500 ^a | M2.5-4 | 1.0-2.5 | 8.8-22.1 | 1500 | 0.8 | 1.8 | 235 | 1/4" Hex | 8431 0170 25 |
| EBL35 | M2.5-4 | 1.0-3.5 | 8.8-31 | 700 | 0.8 | 1.8 | 235 | 1/4" Hex | 8431 0170 33 |
| EBL45 ^c | M2.5-5 | 1.0-4.5 | 8.8-40 | 700 | 0.8 | 1.8 | 235 | 1/4" Hex | 8431 0170 40 |
| EBL55 ^c | M2.5-5 | 1.0-5.5 | 8.8-48 | 600 | 0.8 | 1.8 | 235 | 1/4" Hex | 8431 0170 44 |
| Soft-stop models | | | | | | | | | |
| EBL03-SS | M1-2 | 0.05-0.3 | 0.4-2.7 | 870 | 0.3 | 0.7 | 185 | Wing type 4 mm | 8431 0170 07 |
| EBL12-SS | M2-3 | 0.2-1.2 | 1.8-10.6 | 910 | 0.5 | 1.1 | 215 | 1/4" Hex | 8431 0170 15 |
| EBL20-SS | M2-3 | 0.5-2.0 | 4.5-18 | 750 | 0.5 | 1.1 | 215 | 1/4" Hex | 8431 0170 20 |
| EBL25-SS | M2.5-4 | 1.0-2.5 | 8.8-22.1 | 930 | 0.8 | 1.8 | 235 | 1/4" Hex | 8431 0170 28 |
| EBL35-SS | M2.5-4 | 1.0-3.5 | 8.8-31 | 700 | 0.8 | 1.8 | 235 | 1/4" Hex | 8431 0170 38 |
| Reporting models | | | | | | | | | |
| EBL03-RE | M1-2 | 0.05-0.3 | 0.4-2.7 | 870 | 0.3 | 0.7 | 185 | Wing type 4 mm | 8431 0170 55 |
| EBL03-Q-RE | M1-2 | 0.05-0.3 | 0.4-2.7 | 870 | 0.3 | 0.7 | 185 | 1/4" Hex | 8431 0170 06 |
| EBL12-RE | M2-3 | 0.2-1.2 | 1.8-10.6 | 910 | 0.5 | 1.1 | 215 | 1/4" Hex | 8431 0170 13 |
| EBL12-1500-RE | M2-3 | 0.2-1.2 | 1.8-10.6 | 1500 | 0.5 | 1.1 | 215 | 1/4" Hex | 8431 0170 18 |
| EBL20-RE | M2-3 | 0.5-2.0 | 4.5-18 | 750 | 0.5 | 1.1 | 215 | 1/4" Hex | 8431 0170 19 |
| EBL21-1500-RE | M2-3 | 0.5-2.1 | 4.5-19 | 1500 | 0.8 | 1.8 | 235 | 1/4" Hex | 8431 0170 47 |
| EBL25-RE | M2.5-4 | 1.0-2.5 | 8.8-22.1 | 930 | 0.8 | 1.8 | 235 | 1/4" Hex | 8431 0170 26 |
| EBL25-1500-RE ^b | M2.5-4 | 1.0-2.5 | 8.8-22.1 | 1500 | 0.8 | 1.8 | 235 | 1/4" Hex | 8431 0170 22 |
| EBL35-RE | M2.5-4 | 1.0-3.5 | 8.8-31 | 700 | 0.8 | 1.8 | 235 | 1/4" Hex | 8431 0170 36 |
| EBL45-RE ^d | M2.5-5 | 1.0-4.5 | 8.8-40 | 700 | 0.8 | 1.8 | 235 | 1/4" Hex | 8431 0170 42 |
| EBL55-RE ^d | M2.5-5 | 1.0-5.5 | 8.8-48 | 600 | 0.8 | 1.8 | 235 | 1/4" Hex | 8431 0170 45 |
| Soft-stop Reporting models | | | | | | | | | |
| EBL03-SS-RE | M1-2 | 0.05-0.3 | 0.4-2.7 | 870 | 0.3 | 0.7 | 185 | Wing type 4 mm | 8431 0170 08 |
| EBL12-SS-RE | M2-3 | 0.2-1.2 | 1.8-10.6 | 910 | 0.5 | 1.1 | 215 | 1/4" Hex | 8431 0170 17 |
| EBL20-SS-RE | M2-3 | 0.5-2.0 | 4.5-18 | 750 | 0.5 | 1.1 | 215 | 1/4" Hex | 8431 0170 21 |
| EBL25-SS-RE | M2.5-4 | 1.0-2.5 | 8.8-22.1 | 930 | 0.8 | 1.8 | 235 | 1/4" Hex | 8431 0170 29 |
| EBL35-SS-RE | M2.5-4 | 1.0-3.5 | 8.8-31 | 700 | 0.8 | 1.8 | 235 | 1/4" Hex | 8431 0170 39 |

^a EBL 25-1500 to be used with EBL Drive Plus.

^b EBL 25-1500-RE to be used with EBL Drive Plus and EBL RE Module.

^c EBL 45, 55 to be used with EBL Drive Plus.

NOTE: Max torque reduced to 80% when run on slow speed and soft joints.

^d EBL 45-RE and EBL 55-RE to be used with EBL Drive Plus and EBL RE module.

NOTE: Max torque reduced to 80% when run on slow speed and soft joints.

All tools models, drives and cables are ESD and UL certified.

Tool box include cable for drive connection (standard models with 5 pins cable and reporting models with 6 pins cable)

All the models are push-to-start or lever start configurable.

Optional Accessories

DRIVES

| Model | | Ordering No. |
|---|---|--------------|
| EBL Drive | For standard models and soft-stop models | 8431 0170 70 |
| EBL RE-Drive | For reporting models and soft-stop + reporting models | 8431 0170 75 |
| EBL Drive Plus | For all standard models and soft-stop models | 8431 0170 85 |
| EBL Drive Plus is required for EBL25-1500, EBL25-1500-RE, EBL45, EBL45-RE, EBL55 and EBL55-RE | | |



EBL Drive

EBL REPORTING MODULE

| Model | Ordering No. |
|--|--------------|
| EBL RE module | 8431 0170 76 |
| RE module to be connected between EBL Drive or EBL Drive Plus and RE tool. | |



EBL RE-Drive

VACUUM PICK-UP ACCESSORIES

| Accessories (not ESD approved) | Ordering No. |
|---|--------------|
| Vacuum pump – 220V | 4220 0062 00 |
| Vacuum pump – 115V | 4220 0062 05 |
| Nozzle blank Ø 8 mm for EBL 03 | 4220 0067 03 |
| Nozzle blank Ø 8 mm for EBL 12, 20, 21, 25, 35 | 4220 0070 03 |
| Nozzle blank Ø 14 mm for EBL 12, 20, 21, 25, 35 | 4220 0072 03 |
| Vacuum pick-up adapter for EBL 03 | 4220 0080 30 |
| Vacuum pick-up adapter for EBL 12, 20 | 4220 0080 31 |
| Vacuum pick-up adapter for EBL 21, 25, 35 | 4220 0080 33 |



EBL Drive Plus

CABLES

| Model | Ordering No. |
|--|--------------|
| Cable (not ESD approved) | |
| Spiral cable, 1.3 m (5 pin) | 4220 0347 00 |
| Spiral cable, 1.3 m (6 pin) | 4220 0349 00 |
| Heavy duty, cable 2.0 m (5 pin) | 4216 0132 00 |
| Heavy duty, cable 2.0 m (6 pin) | 4216 0133 00 |
| Cable (ESD approved) | |
| Extension cable ^b 3.0 m (5 pin) | 4220 0138 01 |
| Extension cable ^b 3.0 m (6 pin) | 4216 0115 00 |



EBL RE module

^b Maximum total length 8 m.

SCREW DISPENSER

| Model | Ordering No. |
|---------------------|--------------|
| SDS Screw dispenser | 8432 0830 00 |

PISTOL GRIP

| Model | Ordering No. |
|---------------------------------------|--------------|
| EBL 12, 20 | 4220 0051 04 |
| EBL 21, 25, 35, 45, 55 (ESD approved) | 4220 0051 05 |



Pistol grip



Vacuum pick-up system

ANGLE HEAD

| Model | Ordering No. |
|-----------------------------------|--------------|
| Angle head | |
| Front part square drive 1/4" (06) | 4210 4033 90 |
| Hex bit drive 1/4" (42) | 4210 4033 81 |
| Hex quick change 1/4" (Q) | 4210 4033 82 |
| Adapter | |
| Adapter EBL 12, 20 | 4210 4609 85 |
| Adapter EBL 21/25/35/45/55 | 4210 4609 81 |



Angle head, EBL



Screw dispenser

Both angle head and adapter needs to be ordered for mounting on EBL.

MicroTorque fixtured screwdriver systems are designed to perform consistently and precisely, time after time.

- Complete system, one single ordering number that includes screwdriver, controller, tool cable, PSU and ToolsTalk MT.
- Torque and angle control and monitoring.
- 64 P-sets
- Multiple steps tightening.
- Advanced programming via PC software, ToolsTalk MT.
- Different indication lights for operator feedback.
- Multiple I/Os for integration with assembly line, automation stations or error proofing accessories.



ETD M 08/20/27 ABL V2



ETD M 50/80 ABL V2



ETD M 120/200/250 ABL V2



ETF M 05 400A



ETF M 50/80/100/200 400A

| Model | Torque range | | Speed ^a r/min | Length mm | Overall width mm | Weight | | Bit drive | Ordering No. |
|--|--------------|------------|-----------------------------|--------------|------------------------|--------|------|--------------|--------------|
| | cNm | in lb | | | | kg | lb | | |
| Fixtured transducerized systems | | | | | | | | | |
| ETF MT 5 | 0.5-5 | 0.04-0.4 | 1300 | 183 | 20 | 0.4 | 0.9 | HM 4 mm | 8432 0800 10 |
| ETF MT 10 | 1-10 | 0.09-0.9 | 900 | 183 | 20 | 0.4 | 0.9 | HM 4 mm | 8432 0800 11 |
| ETF MT 20 | 2-20 | 0.18-1.8 | 900 | 183 | 20 | 0.4 | 0.9 | HM 4 mm | 8432 0800 12 |
| ETF MT 50 | 5-50 | 0.44-4.4 | 1300 | 269 | 30 | 1.1 | 2.42 | HM 4 mm | 8432 0800 13 |
| ETF MT 80 | 8-80 | 0.71-7.1 | 1300 | 269 | 30 | 1.2 | 2.65 | HM 4 mm | 8432 0800 14 |
| ETF MT 100 | 10-100 | 0.88-8.8 | 1300 | 272 | 30 | 1.2 | 2.65 | 1/4" HEX | 8432 0800 15 |
| ETF MT 100 HM4 | 10-100 | 0.88-8.8 | 1300 | 269 | 30 | 1.2 | 2.65 | HM 4 mm | 8432 0800 21 |
| ETF MT 200 | 20-200 | 1.77-17.7 | 800 | 272 | 30 | 1.2 | 2.65 | 1/4" HEX | 8432 0800 16 |
| ETF MT 500 | 50-500 | 4.42-44.2 | 500 | 258 | 40 | 1.8 | 4.05 | 1/4" HEX | 8432 0800 17 |
| Fixtured current controlled systems | | | | | | | | | |
| ETF M 05 | 1.5-5 | 0.13-0.4 | 1300 | 183 | 20 | 0.4 | 0.9 | HM 4 mm | 8432 0810 15 |
| ETF M 10 | 3-10 | 0.27-0.9 | 900 | 183 | 20 | 0.4 | 0.9 | HM 4 mm | 8432 0810 16 |
| ETF M 20 | 5-20 | 0.44-1.8 | 900 | 183 | 20 | 0.4 | 0.9 | HM 4 mm | 8432 0810 17 |
| ETF M 50 | 15-50 | 1.33-4.4 | 1300 | 269 | 30 | 1.1 | 2.42 | HM 4 mm | 8432 0810 18 |
| ETF M 80 | 20-80 | 1.77-7.1 | 1300 | 269 | 30 | 1.2 | 2.64 | HM 4 mm | 8432 0810 19 |
| ETF M 100 | 25-100 | 2.21-8.8 | 900 | 272 | 30 | 1.2 | 2.64 | 1/4" HEX | 8432 0810 20 |
| ETF M 200 | 50-200 | 4.42-17.7 | 650 | 272 | 30 | 1.2 | 2.64 | 1/4" HEX | 8432 0810 21 |
| ETF M 400 | 150-400 | 13.27-35.4 | 320 | 258 | 40 | 1.8 | 3.96 | 1/4" HEX | 8432 0810 22 |
| Hand-held current controlled systems, without push-to-start | | | | | | | | | |
| ETD M 20 ABL V2 G4 | 5-20 | 0.44-1.77 | 900 | 185 | 27 | 0.30 | 0.66 | HM 4 mm | 8432 0815 04 |
| ETD M 27 ABL V2 G4 | 7.5-27 | 0.66-2.4 | 900 | 185 | 27 | 0.30 | 0.66 | HM 4 mm | 8432 0815 06 |
| Hand-held current controlled systems, push-start configurable | | | | | | | | | |
| ETD M 50 ABL V2 G4 | 15-50 | 1.33-4.4 | 1300 | 238 | 36 | 0.56 | 1.37 | HM 4 mm | 8432 0815 09 |
| ETD M 80 ABL V2 G4 | 20-80 | 1.77-7.1 | 1300 | 238 | 36 | 0.56 | 1.37 | HM 4 mm | 8432 0815 13 |
| ETD M 120 ABL V2 G4 | 30-120 | 2.7-10.6 | 900 | 240 | 43 | 0.65 | 1.43 | 1/4" HEX | 8432 0815 14 |
| ETD M 200 ABL V2 G4 | 50-200 | 4.42-17.7 | 700 | 240 | 43 | 0.65 | 1.43 | 1/4" HEX | 8432 0815 15 |
| ETD M 250 ABL V2 G4 | 75-250 | 6.64-22.13 | 700 | 240 | 43 | 0.65 | 1.43 | 1/4" HEX | 8432 0815 16 |

MicroTorque fixtured screwdriver system are designed to perform consistently and precisely, time after time.

- Complete systems, one single ordering number that includes screwdriver, controller, Tool Cable, PSU and Tools-Talk MT.
- High accuracy current controlled tools.
- Torque and angle control and monitoring.
- 20 P-sets
- Multiple steps tightening
- Simple programing directly at the controller.
- Advanced programing via PC software, ToolsTalk MT.
- Batch count.
- Different display lights for operator feedback.
- Multiple I/Os for integration with assembly line, automation stations or error proofing accessories.

MTF 400A



ETF M 05 400A



ETF M 50/80/100/200 400A

| Model | Torque range | | Speed r/min | Length mm | Overall width mm | Weight | | Bit drive | Ordering No. |
|---|--------------|-----------|----------------|--------------|------------------------|--------|------|--------------|--------------|
| | cNm | in lb | | | | kg | lb | | |
| Fixtured current controlled, complete system | | | | | | | | | |
| ETF M 50 400A | 15-50 | 1.33-4.4 | 850 | 269 | 30 | 1.1 | 2.42 | HM 4 mm | 8432 0818 18 |
| ETF M 80 400A | 20-80 | 1.77-7.1 | 850 | 269 | 30 | 1.2 | 2.64 | HM 4 mm | 8432 0818 19 |
| ETF M 200 400A | 50-200 | 4.42-17.7 | 600 | 272 | 30 | 1.2 | 2.64 | 1/4" HEX | 8432 0818 21 |

NOTE. Ordering number for complete system. (Screwdriver, MTF 400 controller, tool cable and PSU).

MicroTorque

Handheld screwdrivers V2

MicroTorque handheld screwdrivers are designed to perform consistently and precisely, time after time.

- High accuracy current controlled tools.
- Torque and angle control and monitoring.
- Advanced seating control tightening strategy that eliminates floating screws.
- Ergonomic metallic handle.
- V2 Tools are not paired with the controller and are ordered separately.



ETD M 08/20/27 ABL V2



ETD M 120/200/250 ABL V2



ETD M 50/80 ABL V2

| Model | Torque range | | Speed r/min | Length mm | Overall width mm | Weight | | Bit drive | Ordering No. |
|--|--------------|------------|----------------|--------------|------------------------|--------|------|--------------|--------------|
| | cNm | in lb | | | | kg | lb | | |
| Hand-held current controlled, without push-to-start | | | | | | | | | |
| ETD M 08 ABL V2 | 2-8 | 0.18-0.7 | 1350 | 185 | 29 | 0.30 | 0.66 | HM 4 mm | 8432 0815 18 |
| ETD M 20 ABL V2 | 5-20 | 0.44-1.77 | 900 | 185 | 29 | 0.30 | 0.66 | HM 4 mm | 8432 0815 21 |
| ETD M 27 ABL V2 | 7.5-27 | 0.66-2.4 | 900 | 185 | 29 | 0.30 | 0.66 | HM 4 mm | 8432 0815 27 |
| Hand-held current controlled, push-start configurable | | | | | | | | | |
| ETD M 50 ABL V2 | 15-50 | 1.33-4.4 | 1000 | 238 | 36 | 0.61 | 1.37 | HM 4 mm | 8432 0815 50 |
| ETD M 80 ABL V2 | 20-80 | 1.77-7.1 | 1100 | 238 | 36 | 0.61 | 1.37 | HM 4 mm | 8432 0815 80 |
| ETD M 120 ABL V2 | 30-120 | 2.7-10.6 | 900 | 240 | 43 | 0.65 | 1.43 | 1/4" Hex | 8432 0815 82 |
| ETD M 200 ABL V2 | 50-200 | 4.42-17.7 | 700 | 240 | 43 | 0.65 | 1.43 | 1/4" Hex | 8432 0815 84 |
| ETD M 250 ABL V2 | 75-250 | 6.64-22.13 | 700 | 240 | 43 | 0.65 | 1.43 | 1/4" Hex | 8432 0815 86 |

NOTE. Ordering number for screwdriver only. Tool cable, controller and PSU need to be ordered separately.

MicroTorque

Fixtured screwdrivers V2

MicroTorque fixtured screwdrivers are designed to perform consistently and precisely, time after time.

- High accuracy current controlled tools.
- Torque and angle control and monitoring.
- Advanced seating control tightening strategy that eliminates floating screws.
- Very compact design.
- V2 Tools are not paired with the controller and are ordered separately.



ETF S

| Model | Torque range | | Speed r/min | Length mm | Overall width mm | Weight | | Bit drive | Ordering No. |
|------------------------------------|--------------|-----------|----------------|--------------|------------------------|--------|------|--------------|--------------|
| | cNm | in lb | | | | kg | lb | | |
| Fixtured current controlled | | | | | | | | | |
| ETF S 08 V2 | 2-8 | 0.18-0.70 | 1500 | 125 | 65 | 0.3 | 0.68 | HM 4 mm | 8432 0832 84 |
| ETF S 25 V2 | 5.5-25 | 0.49-2.2 | 1000 | 125 | 65 | 0.3 | 0.68 | HM 4 mm | 8432 0832 85 |

NOTE. Ordering number for screwdriver only. Tool cable, controller and PSU need to be ordered separately.

MT Focus 400 is an extremely compact and advanced controller designed to attend the most demanding assembly processes.

- 20 P-sets
- Multiple step tightening
- Simple programming directly at the controller.
- Advanced programming via PC software, ToolsTalk MT.
- Batch count.
- Different display lights for operator feedback.
- Multiple I/Os for integration with assembly line, automation stations or error proofing accessories.
- ToolsTalk MT included, with Graph Analysis and Net functionality for detailed information.



MTF 400A

| Model | Ordering No. |
|----------|--------------|
| MTF 400A | 8432 0850 00 |

NOTE: To be ordered together with V2 tools.

MicroTorque

Accessories

TOOL CABLES FOR ETF S V2 AND ETD M ABL V2

| Model | Ordering No. |
|-------------|--------------|
| Cable 2 m | 8432 0835 02 |
| Cable 3.5 m | 8432 0835 03 |



Tool cable

POWER SUPPLY UNIT, PSU

| Model | Battery / Power | Ordering No. |
|-------------------------------------|-----------------|--------------|
| ETF S08 V2 and ETD M08/20/27 ABL V2 | 24V / 72W | 8432 0840 00 |
| ETF S25 V2 | 36V / 72W | 8432 0840 01 |
| ETD M50/80/100/120/200/250 ABL V2 | 36V / 180W | 8432 0840 02 |



Power supply unit

Optional Accessories

CONTROLLER ACCESSORIES FOR MT G4

| Model | Ordering No. |
|--|--------------|
| Combi (Remote control + program selector) | 8432 0830 88 |
| Remote control | 8432 0830 08 |
| Digital program selector | 8432 0830 34 |
| Controller table fixture | 8432 0830 84 |
| Controller wall fixture | 8432 0830 32 |
| Y cable for I/O connector ^a | 8432 0831 99 |
| Desktop socket (with screwdriver presence sensor) | 8432 0831 89 |
| MT TN adapter ToolsNet 4000 ^b (15 pin/26 pin d-sub) | 8432 0832 98 |

^a Y cable suitable when two I/O accessories are required.

^b Including adapter cables.



Digital program selector



Remote control



Desktop socket



MT G4 table fixture

CONTROLLER ACCESSORIES FOR MTF 400

| Model | Ordering No. |
|--|--------------|
| Digital program selector | 8432 0830 65 |
| Controller wall fixture | 8432 0833 83 |
| MT TN adapter ToolsNet 4000 ^c | 8432 0832 98 |

^c Including adapter cables.



MT G4 wall fixture

STACKLIGHTS

| Model | Ordering No. |
|--------------------------|--------------|
| Table stand ^d | 8432 0830 97 |
| Wall mount ^d | 8432 0830 99 |

^d Adapter included, suitable for MT G4 and MTF400 controllers.



Stacklight wall mount



Stacklight table stand

TOOL CABLE

| Model | Length | Ordering No. |
|------------------------------|--------|--------------|
| ETD M ABL, ETF S | 2 m | 8432 0835 02 |
| ETD M ABL, ETF S | 3.5 m | 8432 0835 03 |
| ETF M, MT | 2 m | 8432 0830 36 |
| ETF M, MT | 3.5 m | 8432 0831 01 |
| ETF M, MT 90 deg angle cable | 2 m | 8432 0831 15 |



Tool cable



Tool cable, 90 deg

CABLE ACCESSORIES

| Model | Ordering No. |
|------------------|--------------|
| Cable, RS232 | 8432 0830 38 |
| Cable, USB | 8432 0830 39 |
| Transducer cable | 8432 0830 35 |
| Cable bracket | 8432 0830 91 |

Optional Accessories

VACUUM ADAPTER

| Model | Nozzle Ø mm | Tool Bit Drive | Tool model | Ordering No. |
|-------------------------|-------------|----------------|--|--------------|
| QC Vacuum Adapter Small | 8 | HM4 | ETD M, ETF S, ETF M, ETF MT and QMC | 8432 0770 58 |
| QC Vacuum Adapter Large | 12 | 1/4" HEX | ETD M and QMC | 8432 0770 57 |
| QC Vacuum Adapter Large | 12 | 1/4" HEX | ETF M100, ETF MT100, ETF M200 and ETFMT200 | 8432 0770 59 |



Vacuum adapter

VACUUM NOZZLES

| Model | Nozzle Ø mm | Tool Bit Drive | Ordering No. |
|-----------------|-------------|----------------|--------------|
| Plastic Nozzle | 8 | HM4 | 4216 1190 16 |
| Metallic Nozzle | 8 | HM4 | 4216 1190 17 |
| Plastic Nozzle | 12 | 1/4" HEX | 4216 1190 20 |
| Metallic Nozzle | 12 | 1/4" HEX | 4216 1190 21 |



Vacuum nozzles

VACUUM PUMP

| Model | Ordering No. |
|--------------------|--------------|
| Vacuum pump, VPX 6 | 8432 0830 06 |



VPX 6 vacuum pump

SCREW DISPENSER

| Model | Screw size | Ordering No. |
|---|------------|--------------|
| Screw dispenser for magnetized bit | | |
| SDS screw dispenser | M1.0 - 5.0 | 8432 0830 00 |
| Screw dispenser for vacuum pick up | | |
| SDS SR 10 | M1.0 | 8432 0870 30 |
| SDS SR 12 | M1.2 | 8432 0870 32 |
| SDS SR 14 | M1.4 | 8432 0870 34 |
| SDS SR 17 | M1.7 | 8432 0870 31 |
| SDS SR 20 | M2.0 | 8432 0870 33 |
| SDS SR 23 | M2.3 | 8432 0870 35 |
| SDS SR 26 | M2.6 | 8432 0870 36 |
| SDS SR 30 | M3.0 | 8432 0870 37 |



Screw dispenser for magnetic bit



Screw dispenser for vacuum pick up

Tensor ES

TENSOR ES

- Torque transducer with an accuracy of $\pm 7.5\%$ over six sigma.
- Robust, sealed design with one single extruded aluminum body protecting internal components from dust and oil.
- New durable motor with higher speeds.
- Engineered in modules with component commonality.
- Clear LEDs visible through 360°.
- Hot swap.



| Model | Square drive in | Torque range | | Speed r/min | Weight | | Length mm | CS distance mm | Spline/ Mounting | Ordering No. |
|-----------------------------|--------------------|--------------|------------|----------------|--------|------|--------------|-------------------|---------------------|--------------|
| | | Nm | ft lb | | kg | lb | | | | |
| Angle models | | | | | | | | | | |
| ETV ES21-04-06 | 1/4 | 1.6-4.5 | 1.2-3.3 | 1909 | 0.85 | 1.9 | 284 | 9.5 | – | 8436 0120 04 |
| ETV ES21-07-06 | 1/4 | 2.8-7 | 2.1-5.2 | 1147 | 0.85 | 1.9 | 284 | 9.5 | – | 8436 0120 07 |
| ETV ES21-12-06 | 1/4 | 4.8-12 | 3.5-8.9 | 718 | 0.95 | 2.1 | 304 | 11 | – | 8436 0120 12 |
| ETV ES21-20-10 | 3/8 | 8-20 | 5.9-14.8 | 430 | 1.05 | 2.3 | 303 | 14 | – | 8436 0120 20 |
| ETV ES61-25-10 | 3/8 | 10-25 | 7.4-18.4 | 1378 | 1.8 | 4.0 | 419 | 14 | – | 8436 0160 25 |
| ETV ES61-30-10 | 3/8 | 12-30 | 8.9-22.1 | 1160 | 1.8 | 4.0 | 421 | 15.5 | – | 8436 0160 30 |
| ETV ES61-40-10 | 3/8 | 16-40 | 11.8-29.5 | 1153 | 1.9 | 4.2 | 441 | 18 | – | 8436 0160 40 |
| ETV ES61-50-10 | 3/8 | 20-50 | 14.8-36.9 | 692 | 1.9 | 4.2 | 441 | 18 | – | 8436 0160 50 |
| ETV ES61-70-13 | 1/2 | 28-70 | 20.7-51.6 | 439 | 3.1 | 6.8 | 499 | 20 | – | 8436 0160 70 |
| ETV ES61-100-13 | 1/2 | 40-100 | 29.5-73.8 | 370 | 3.15 | 6.9 | 505 | 22.5 | – | 8436 0160 10 |
| ETV ES61-150-13 | 1/2 | 60-150 | 44.3-110.6 | 296 | 3.2 | 7.1 | 541 | 26 | – | 8436 0160 15 |
| ETV ES61-180-13 | 1/2 | 72-180 | 53-133 | 232 | 3.2 | 7.1 | 541 | 26 | – | 8436 0160 18 |
| ETV ES61-200-20 | 3/4 | 80-200 | 59-147.5 | 203 | 3.4 | 7.5 | 543 | 27 | – | 8436 0160 20 |
| Angle, quick chuck | | | | | | | | | | |
| ETV ES21-12-106-QC | – | 4.8-12 | 3.5-8.9 | 718 | 0.95 | 2.1 | 304 | 11 | – | 8436 0121 12 |
| Angle, ball retainer | | | | | | | | | | |
| ETV ES61-70-B13 | 1/2 | 28-70 | 20.7-51.6 | 439 | 3.1 | 6.8 | 499 | 20 | – | 8436 0165 70 |
| ETV ES61-100-B13 | 1/2 | 40-100 | 29.5-73.8 | 370 | 3.15 | 6.9 | 505 | 22.5 | – | 8436 0165 10 |
| Straight models | | | | | | | | | | |
| ETD ES21-02-106-PS | – | 0.8-2 | 0.6-1.5 | 4471 | 0.75 | 1.7 | 267 | 19.5 | – | 8436 0220 02 |
| ETD ES21-04-106-PS | – | 1.6-4 | 1.2-3 | 1909 | 0.8 | 1.8 | 267 | 19.5 | – | 8436 0220 04 |
| ETD ES21-07-106-PS | – | 2.8-7 | 2.1-5.2 | 1147 | 0.8 | 1.8 | 267 | 19.5 | – | 8436 0220 07 |
| ETD ES21-12-106-PS | – | 4.8-12 | 3.5-8.9 | 745 | 0.8 | 1.8 | 267 | 19.5 | – | 8436 0220 12 |
| ETD ES61-18-10 | 3/8 | 7.2-18 | 5.3-13.3 | 2129 | 1.7 | 3.75 | 418 | 23 | -/1 | 8436 0265 18 |
| ETD ES61-18-10-T25 | 3/8 | 7.2-18 | 5.3-13.3 | 2129 | 1.85 | 4.1 | 456 | 23 | 2/2 | 8436 0260 18 |
| ETD ES61-25-10 | 3/8 | 10-25 | 7.4-18.4 | 1793 | 1.7 | 3.8 | 418 | 23 | -/1 | 8436 0265 25 |
| ETD ES61-25-10-T25 | 3/8 | 10-25 | 7.4-18.4 | 1793 | 1.85 | 4.1 | 456 | 23 | 2/2 | 8436 0260 25 |
| ETD ES61-30-10 | 3/8 | 12-30 | 8.9-22.1 | 1077 | 1.7 | 3.8 | 418 | 23 | -/1 | 8436 0265 30 |
| ETD ES61-30-10-T25 | 3/8 | 12-30 | 8.9-22.1 | 1077 | 1.85 | 4.1 | 456 | 23 | 2/2 | 8436 0260 30 |
| ETD ES61-50-13 | 1/2 | 20-50 | 14.8-36.9 | 679 | 2.95 | 6.5 | 493 | 29 | 2/2 | 8436 0265 50 |
| ETD ES61-50-13-T25 | 1/2 | 20-50 | 14.8-36.9 | 679 | 3.05 | 6.7 | 521 | 29 | 3/5 | 8436 0260 50 |
| ETD ES61-70-13 | 1/2 | 28-70 | 20.7-51.6 | 608 | 2.95 | 6.5 | 493 | 29 | 2/2 | 8436 0265 70 |
| ETD ES61-70-13-T25 | 1/2 | 28-70 | 20.7-51.6 | 608 | 3.1 | 6.8 | 521 | 29 | 3/5 | 8436 0260 70 |
| ETD ES61-90-13 | 1/2 | 36-90 | 26.6-66.4 | 467 | 2.95 | 6.5 | 493 | 29 | 2/2 | 8436 0265 90 |
| ETD ES61-90-13-T25 | 1/2 | 36-90 | 26.6-66.4 | 467 | 3.1 | 6.8 | 521 | 29 | 3/5 | 8436 0260 90 |
| ETD ES61-120-13 | 1/2 | 48-120 | 35.4-88.5 | 365 | 2.95 | 6.5 | 493 | 29 | 2/2 | 8436 0265 12 |
| ETD ES61-120-13-T25 | 1/2 | 48-120 | 35.4-88.5 | 365 | 3.1 | 6.8 | 521 | 29 | 3/5 | 8436 0260 12 |
| Fixtured models | | | | | | | | | | |
| ETF ES21-04-106-T25 | – | 1.6-4 | 1.2-3 | 1909 | 0.96 | 2.1 | 338 | 22.5 | – ^a | 8436 0224 04 |
| ETF ES21-07-106-T25 | – | 2.8-7 | 2.1-5.2 | 1147 | 0.96 | 2.1 | 338 | 22.5 | – ^a | 8436 0224 07 |
| ETF ES21-12-106-T25 | – | 4.8-12 | 3.5-8.9 | 745 | 0.96 | 2.1 | 338 | 22.5 | – ^a | 8436 0224 12 |
| Pistol grip models | | | | | | | | | | |
| ETP ES21-02-106-PS | – | 0.8-2 | 0.6-1.5 | 4471 | 0.85 | 1.87 | 225 | 19.5 | – | 8436 0320 02 |
| ETP ES21-04-106-PS | – | 1.6-4 | 1.2-3 | 1909 | 0.85 | 1.87 | 225 | 19.5 | – | 8436 0320 04 |
| ETP ES21-07-106-PS | – | 2.8-7 | 2.1-5.2 | 1147 | 0.85 | 1.87 | 225 | 19.5 | – | 8436 0320 07 |
| ETP ES21-12-106-PS | – | 4.8-12 | 3.5-8.9 | 745 | 0.85 | 1.87 | 225 | 19.5 | – | 8436 0320 12 |

^a Mounting bracket fixed.

Tensor DL non-transducerized screwdrivers exist in two different tool configurations:

ETP – Pistol grip handle screwdrivers with configurable function button. Available as lever and push to start.

ETF – Straight screwdrivers for fixtured applications. Configurable lever or remote start.

- The DL screwdriver range has been optimized for small screw assembly.
- Torque range up to 10 Nm.
- All tools have ESD certification.
- Ergonomic design promotes operator safety.
- Brushless motor gives long service intervals and low maintenance costs.
- Signal lights ensure detection of incorrectly tightened fasteners.



ETF DL



ETP DL

| Model | Torque range | | Speed r/min | Weight | | Length mm | CS distance mm | Ordering No. |
|--|--------------|-----------|----------------|--------|-----|--------------|-------------------|--------------|
| | Nm | in lb | | kg | lb | | | |
| Pistol grip, lever start | | | | | | | | |
| ETP DL21-04-I06 | 1-4 | 8.8-35.4 | 1600 | 0.6 | 1.3 | 235 | 20 | 8433 4024 19 |
| ETP DL21-07-I06 | 2.2-7.5 | 19.5-66 | 970 | 0.6 | 1.3 | 235 | 20 | 8433 4027 26 |
| ETP DL21-10-I06 | 3-10 | 26.6-88.5 | 720 | 0.6 | 1.3 | 235 | 20 | 8433 4029 13 |
| Pistol grip, push-to-start and front lights | | | | | | | | |
| ETP DL21-01-I06-PS-H | 0.3-1.2 | 2.6-10 | 2200 | 0.6 | 1.3 | 243 | 20 | 8433 4020 77 |
| ETP DL21-04-I06-PS-H | 1-4 | 8.8-35.4 | 1600 | 0.6 | 1.3 | 243 | 20 | 8433 4024 66 |
| ETP DL21-07-I06-PS-H | 2.2-7.5 | 19.5-66 | 970 | 0.6 | 1.3 | 243 | 20 | 8433 4027 53 |
| ETP DL21-10-I06-PS-H | 3-10 | 26.6-88.5 | 720 | 0.6 | 1.3 | 243 | 20 | 8433 4029 28 |
| Fixtured tools, lever start or remote start | | | | | | | | |
| ETF DL21-01-I06-T25 | 0.3-1.2 | 2.6-10 | 2200 | 0.7 | 1.5 | 328 | 18 / 19.5 | 8433 4040 04 |
| ETF DL21-04-I06-T25 | 1-4 | 8.8-35.4 | 1600 | 0.7 | 1.5 | 328 | 18 / 19.5 | 8433 4042 13 |
| ETF DL21-07-I06-T25 | 2.2-7.5 | 19.5-66 | 970 | 0.7 | 1.5 | 328 | 18 / 19.5 | 8433 4043 22 |
| ETF DL21-10-I06-T25 | 3-10 | 26.6-88.5 | 720 | 0.7 | 1.5 | 328 | 18 / 19.5 | 8433 4044 11 |

Tensor SL

ETD SL

- ETD SL is a very compact screwdriver with excellent power to weight ratio.
- Torque range from 0.3 to 10 Nm.
- Push-to-start function and front lights.
- Small center-to-side distance.
- Ergonomic design.
- Buzzer and additional blue LED for better operator support.



ETD SL



ETP SL



ETV SL



ETF SL

ETV SL

- ETV SL is the most compact transducerised angle screwdriver in the Tensor range.
- Torque range from 0.8 to 20 Nm.
- High durability with spiral angle gears.
- Ergonomic design.
- Buzzer and additional blue LED for better operator support.

ETP SL

- ETP SL is our first push-to-start pistol tool.
- Torque range from 0.3 to 10 Nm.
- Ergonomic, balanced pistol tool.
- Front lights for dark applications.
- Blue light and buzzer.

ETF SL

- ETF SL is the smallest and lightest fixtured tool.
- Torque range from 0.3 to 10 Nm.
- Stroke with 25 mm suspension.
- Small center-to-side distance.

| Model | Torque range | | Speed r/min | Weight | | Length mm | CS distance ^a mm | Stroke mm | Ordering No. |
|---|--------------|--------|----------------|--------|-----|--------------|--------------------------------|--------------|--------------|
| | Nm | in lb | | kg | lb | | | | |
| Straight tools, push-to-start and front lights | | | | | | | | | |
| ETD SL21-01-I06-PS | 0.3-1.2 | 2.7-10 | 2950 | 0.7 | 1.6 | 246 | 18/19.5 | — | 8433 2102 92 |
| ETD SL21-04-I06-PS | 0.8-4 | 7-35 | 1600 | 0.7 | 1.6 | 246 | 18/19.5 | — | 8433 2104 91 |
| ETD SL21-07-I06-PS | 1.5-7.5 | 13-66 | 970 | 0.7 | 1.6 | 246 | 18/19.5 | — | 8433 2107 69 |
| ETD SL21-10-I06-PS | 2.0-10 | 18-89 | 720 | 0.7 | 1.6 | 246 | 18/19.5 | — | 8433 2108 25 |
| Right angle tools, lever start | | | | | | | | | |
| ETV SL21-04-I06 | 0.8-4 | 7-35 | 1600 | 0.75 | 1.7 | 279 | 9 | — | 8433 2004 47 |
| ETV SL21-04-I06-QC | 0.8-4 | 8-35 | 1600 | 0.75 | 1.7 | 279 | 9 | — | 8433 2004 73 |
| ETV SL21-04-06 | 0.8-4 | 9-35 | 1600 | 0.75 | 1.7 | 279 | 9 | — | 8433 2004 91 |
| ETV SL21-07-I06 | 1.5-7.5 | 13-66 | 970 | 0.75 | 1.7 | 279 | 9 | — | 8433 2007 66 |
| ETV SL21-07-I06-QC | 1.5-7.5 | 14-66 | 970 | 0.75 | 1.7 | 279 | 9 | — | 8433 2007 79 |
| ETV SL21-07-06 | 1.5-7.5 | 15-66 | 970 | 0.75 | 1.7 | 279 | 9 | — | 8433 2007 94 |
| ETV SL21-12-I06 | 2.5-12 | 22-106 | 610 | 0.8 | 1.8 | 282 | 11 | — | 8433 2008 34 |
| ETV SL21-12-I06-QC | 2.5-12 | 23-106 | 610 | 0.8 | 1.8 | 282 | 11 | — | 8433 2008 61 |
| ETV SL21-12-06 | 2.5-12 | 24-106 | 610 | 0.8 | 1.8 | 282 | 11 | — | 8433 2008 77 |
| ETV SL21-20-10 | 4-20 | 36-180 | 465 | 0.95 | 2.1 | 285 | 14 | — | 8433 2009 55 |
| ETV SL21-20-B10 | 4-20 | 36-180 | 465 | 0.95 | 2.1 | 285 | 14 | — | 8433 2009 60 |
| Pistol grip, push-to-start | | | | | | | | | |
| ETP SL21-01-I06-PS | 0.3-1.2 | 2.7-10 | 3000 | 0.85 | 1.9 | 246 | 20.5 | — | 8433 2201 16 |
| ETP SL21-04-PS | 0.8-4 | 7-35 | 1600 | 0.85 | 1.9 | 246 | 20.5 | — | 8433 2204 66 |
| ETP SL21-07-PS | 1.5-7.5 | 13-66 | 970 | 0.85 | 1.9 | 246 | 20.5 | — | 8433 2207 53 |
| ETP SL21-10-PS | 2-10 | 18-89 | 720 | 0.85 | 1.9 | 246 | 20.5 | — | 8433 2208 28 |
| Fixtured tools, lever start or remote start | | | | | | | | | |
| ETF SL21-01-I06-T25 | 0.3-1.2 | 2.7-10 | 3000 | 0.95 | 2.1 | 322 | 18 | 25 | 8433 2404 13 |
| ETF SL21-04-I06-T25 | 0.8-4 | 7-35 | 1600 | 0.95 | 2.1 | 322 | 18 | 25 | 8433 2404 19 |
| ETF SL21-07-I06-T25 | 1.5-7.5 | 13-66 | 970 | 0.95 | 2.1 | 322 | 18 | 25 | 8433 2407 26 |
| ETF SL21-10-I06-T25 | 2-10 | 18-89 | 720 | 0.95 | 2.1 | 322 | 18 | 25 | 8433 2408 13 |

^a For ETV, CS distance over angle head.

ETV SR

- SR Angle tools are extremely fast, compact and easy to operate.
- ESD certified.
- Easy to configure the function button.
- Front LED's gives better operator feedback.
- Torque range from 2.5 to 30 Nm.



ETV SR

ETD SR

- SR Straight tools are ideal for hand-held applications and fixture applications.
- ESD certified.
- Front light guide is integrated.
- Push-to-start mechanism.
- Torque range from 1.5 to 16 Nm.



ETD SR

| Model | Torque range | | Speed r/min | Weight | | Length mm | CS distance mm | Spline/ Mounting | Ordering No. |
|------------------------|--------------|----------|----------------|--------|-----|--------------|-------------------|---------------------|--------------|
| | Nm | ft lb | | kg | lb | | | | |
| Angle models | | | | | | | | | |
| ETV SR21-12-10 | 2.5-12 | 1.9-8.9 | 1350 | 1.1 | 2.4 | 297 | 14 | - | 8436 4120 12 |
| ETV SR21-25-10 | 5-25 | 3.7-18.5 | 1000 | 1.2 | 2.6 | 297 | 14 | - | 8436 4120 25 |
| ETV SR21-30-10 | 6-30 | 4.4-22.1 | 663 | 1.2 | 2.6 | 299 | 15.5 | - | 8436 4120 30 |
| Straight models | | | | | | | | | |
| ETD SR21-07-I06-PS | 1.5-7 | 1.0-5.2 | 2090 | 0.9 | 1.9 | 259 | 24 | - | 8436 4220 07 |
| ETD SR21-16-I06-PS | 3.5-16 | 2.6-11.8 | 1460 | 1.0 | 2.2 | 276 | 24 | - | 8436 4220 16 |
| ETD SR21-07-I06-T25 | 1.5-7 | 1.0-5.2 | 2090 | 0.9 | 1.9 | 353 | 24 | - | 8436 4224 07 |
| ETD SR21-16-10-T25 | 3.5-16 | 2.6-11.8 | 1460 | 1.0 | 2.2 | 353 | 24 | - | 8436 4224 17 |

Optional Accessories

COVERS FOR STANDARD SOCKETS

| Model | Ordering No. |
|-----------------------|--------------|
| ETD ES61-18/ 25/ 30 | 4220 3251 02 |
| ETD ES61-50 | 4220 3251 03 |
| ETV ES61-30 | 4220 3154 04 |
| ETV ES61-100 | 4220 3154 05 |
| ETV ES61-40/50 | 4220 1995 05 |
| ETV ES61-70 | 4220 1993 03 |
| ETV SL21, ETV ES61-25 | 4220 3154 03 |



Cover for standard sockets

SUPPORTED EXTENSIONS (~154 MM)

| Model | Ordering No. |
|----------------|--------------|
| SR21, ETV SL21 | 4220 3868 90 |



Supported extensions

SUSPENSION YOKES DL/SL/SR

| Model | Type | Assembly | Ordering No. |
|------------|------------|----------|--------------|
| ETD/ETV SL | Horizontal | Motor | 4220 0987 81 |
| SR21 | For rear | | 4220 4410 80 |
| SR21 | For front | | 4220 4409 80 |

PISTOL GRIP TENSOR DL / SL

| Model | Ordering No. |
|-----------|--------------|
| Tensor DL | 4220 2743 90 |
| Tensor SL | 4220 3516 80 |

Pistol grip can be mounted on all straight DL tools.



Pistol grip
Tensor DL/SL

SUPPORT HANDLE

| Model | Ordering No. |
|--------------|--------------|
| ETV/ETD ES21 | 4220 2725 83 |
| ETD SR21 | 4220 4347 80 |



Support handle

LEVER

| Model | Ordering No. |
|--------------------------|--------------|
| Lever SL | 4220 2540 81 |
| Extended lever SL | 4220 2540 89 |
| Spoon lever SR21 | 4220 4338 83 |
| Short lever ETV/ETD ES21 | 4220 4366 86 |
| Long lever ETV/ETD ES21 | 4220 4366 85 |



TOOL HOLDER DL / SL

| Model | Ordering No. |
|-----------|--------------|
| ETP / ETD | 4220 3584 80 |

Tool holder

Optional Accessories

CABLES TENSOR ES

| Model | Ordering No. |
|--|--------------|
| Round cables for ES21 | |
| 2 m | 4220 4204 02 |
| 3 m | 4220 4204 03 |
| 5 m | 4220 4204 05 |
| 7 m | 4220 4204 07 |
| 10 m | 4220 4204 10 |
| 15 m | 4220 4204 15 |
| Flat cables for ES61 | |
| 3 m | 4220 4339 03 |
| 5 m | 4220 4339 05 |
| 7 m | 4220 4339 07 |
| 10 m | 4220 4339 10 |
| 15 m | 4220 4339 15 |
| Extension cables for all cables | |
| 3 m | 4220 4393 03 |
| 5 m | 4220 4393 05 |
| 10 m | 4220 4393 10 |
| 15 m | 4220 4393 15 |
| 25 m | 4220 4393 25 |

CABLES TENSOR DL

| Model | Ordering No. |
|---|--------------|
| Tool cable | |
| 3 m | 4220 2604 03 |
| 5 m | 4220 2604 05 |
| 10 m | 4220 2604 10 |
| 15 m | 4220 2604 15 |
| Heavy duty cable | |
| 3 m | 4220 3265 03 |
| 5 m | 4220 3265 05 |
| 10 m | 4220 3265 10 |
| Cables with 90 degrees connector | |
| 3 m | 4220 3705 03 |
| 5 m | 4220 3705 05 |
| 10 m | 4220 3705 10 |
| Spiral cable straight | |
| 5 m | 4220 3240 05 |
| Spiral cable with 90 degrees connector | |
| 5 m | 4220 3706 05 |
| Extension cable | |
| 3 m | 4220 2795 03 |
| 5 m | 4220 2795 05 |
| 10 m | 4220 2795 10 |



DL Cable



DL cable with 90 degrees connector



DL spiral cable

Optional Accessories

CABLESTENSOR SL

| Model | Ordering No. |
|---|--------------|
| Tool cable | |
| 3 m | 4220 3319 03 |
| 5 m | 4220 3319 05 |
| 10 m | 4220 3319 10 |
| 15 m | 4220 3319 15 |
| Heavy duty cable | |
| 3 m | 4220 3378 03 |
| 5 m | 4220 3378 05 |
| 10 m | 4220 3378 10 |
| 15 m | 4220 3378 15 |
| Cables with 90 degrees connector | |
| 3 m | 4220 3607 03 |
| 5 m | 4220 3607 05 |
| 10 m | 4220 3607 10 |
| 20 m | 4220 3607 20 |
| Spiral cable straight | |
| 5 m | 4220 3746 05 |
| Spiral cable with 90 degrees connector | |
| 5 m | 4220 3617 05 |
| Extension cable | |
| 3 m | 4220 2795 03 |
| 5 m | 4220 2795 05 |
| 10 m | 4220 2795 10 |



SL Cable



SL Cable with 90 degrees connector



SL Spiral cable



SR Cable



SR Cable with 90 degrees connector



SR Spiral cable



SR Cable protection

CABLESTENSOR SR

| Model | Ordering No. |
|---|--------------|
| Tool cable | |
| 2 m | 4220 2636 02 |
| 3 m | 4220 2636 03 |
| 5 m | 4220 2636 05 |
| 7 m | 4220 2636 07 |
| 10 m | 4220 2636 10 |
| 15 m | 4220 2636 15 |
| Cables with 90 degrees connector | |
| 2 m | 4220 3891 02 |
| 3 m | 4220 3891 03 |
| 5 m | 4220 3891 05 |
| 7 m | 4220 3891 07 |
| 10 m | 4220 3891 10 |
| 15 m | 4220 3891 15 |
| Extension cable | |
| 5 m | 4220 1007 05 |
| 10 m | 4220 1007 10 |
| 15 m | 4220 1007 15 |
| Extension cables for fixtured applications | |
| 5 m | 4220 1563 05 |
| 10 m | 4220 1563 10 |
| 15 m | 4220 1563 15 |
| Spiral cable (length/stretched length) | |
| 3 m / 4 m | 4220 2757 03 |
| 7 m / 8 m | 4220 2757 07 |
| 10 m / 12 m | 4220 2757 10 |
| Cable protection | |
| | 4220 2977 90 |

Tensor – the operators' choice

The Tensor range of electric assembly tools covers all station and assembly line requirements for safety critical and quality critical fastening applications. At Atlas Copco we have a proud legacy of putting the operator first and we continuously improve the ergonomic features on each new generation of Tensor tools. Tensor is also one of the most advanced tool ranges on the market in terms of high power-to-weight ratios and operator guidance in the form of clear result feedback via LED's or audio signals.

PRODUCTIVITY GAINS

Atlas Copco's unique Tensor motors give the Tensor range outstanding spindle speeds and, thus, help you achieve lower cycle times in your operation. Exceptional ergonomics in terms of balance, grip and low weight make the tools a favorite of the operators and increase individual productivity.

OPERATOR FEEDBACK

All Tensor tools are equipped with LED's that will indicate the tightening result, green light for tightening OK and red light for NOK. Tensor ST and STR have configurable LED's and an integrated speaker for indicating results via audio signals.

LOWEST COST OF OPERATION

At Atlas Copco we believe that quality is the road to lowest cost of operation over time. A maintained Tensor tool produces the same performance year after year at minimum and predictable costs while ensuring highest possible uptime.

TENSOR TOOLS

Tensor DL: quality critical

The Tensor DL range is used for quality critical screws. Optimized for small screw assembly, the DL is the electric choice in the low torque segment.

Tensor SL: low torque safety critical, configurable tool functions

The Tensor SL range is optimized for safety critical small screw assembly. It offers compact screwdriver ergonomics, combined with traceability and error proofing capabilities.

Tensor DS: quality critical

Tensor DS is used for quality critical applications not requiring traceable measured torque value. DS offers major productivity and quality gains compared with conventional tooling.

Tensor ST: safety critical, configurable tool functions

The second generation of Tensor tools was developed with low weight and productivity in mind. Tensor ST has an internal bus connection for intelligent accessories such as a barcode reader and torque selector switch.

Tensor STR, SR: safety critical, configurable tool functions

The latest generation of Tensor tools where ergonomics and productivity are taken to a new level.

Tensor ES: quality critical

Tensor ES transducerized nutrunners for quality critical applications are available in straight and right angle versions. All models have a sealed design for robustness and offer high productivity with improved ergonomics.



Tensor Overview



POWER FOCUS 6000 POWER FOCUS 600 POWER FOCUS 4000 POWER FOCUS 4002 IRC FOCUS

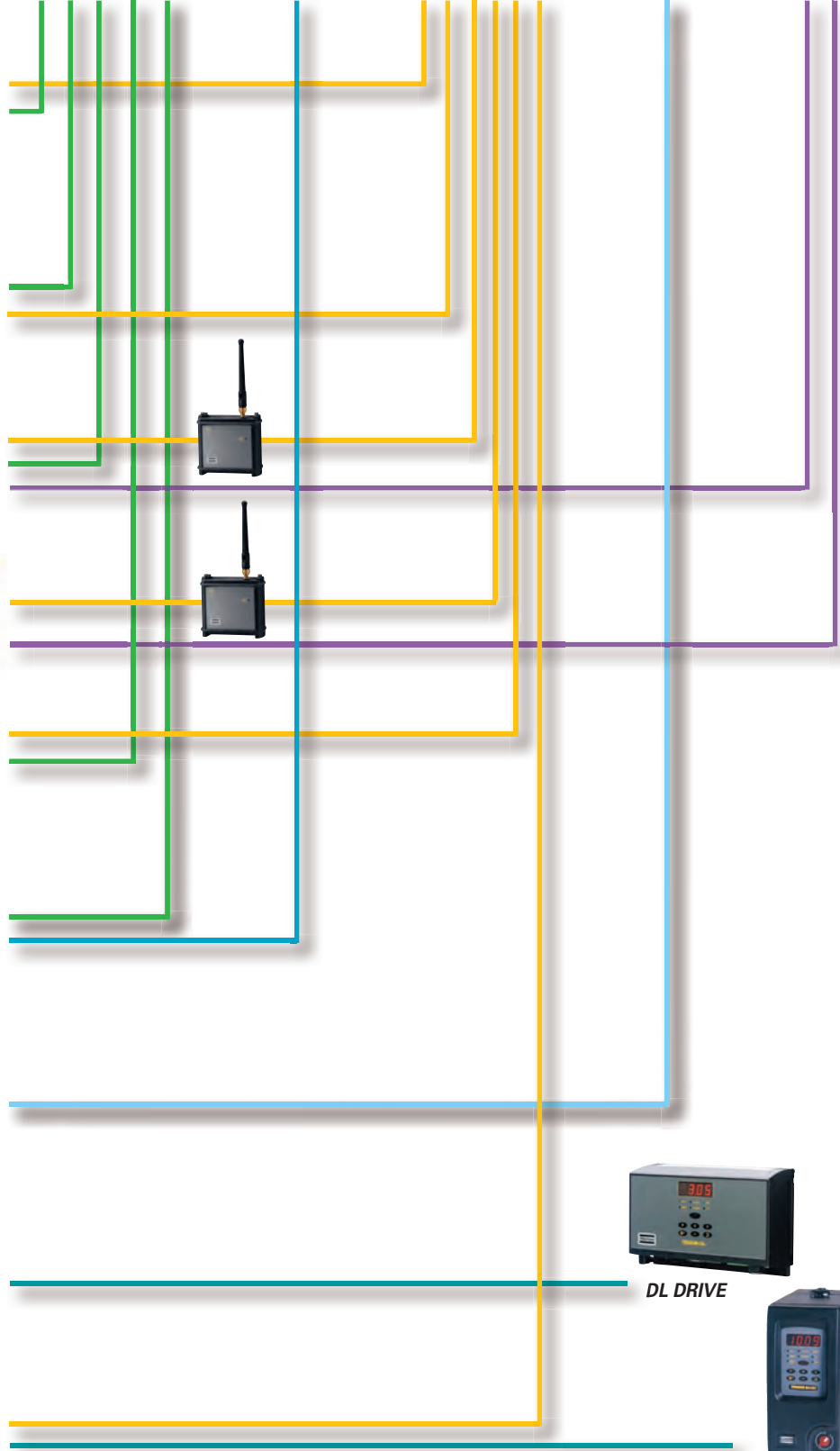
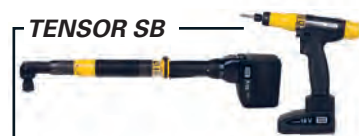

DL DRIVE



DS DRIVE

TENSOR ES

- Torque transducer with an accuracy of $\pm 7.5\%$ over six sigma.
- Robust, sealed design.
- New durable motor with higher speeds.
- Engineered in modules with component commonality.
- Clear LEDs visible through 360°.
- Hot swap.



| Model | Square drive in | Torque range | | Speed r/min | Weight | | Length mm | CS distance mm | Splines/ Mounting | Ordering No. |
|-----------------------------|--------------------|--------------|------------|----------------|--------|------|--------------|-------------------|----------------------|--------------|
| | | Nm | ft lb | | kg | lb | | | | |
| Angle models | | | | | | | | | | |
| ETV ES21-04-06 | 1/4 | 1.6-4.5 | 1.2-3.3 | 1909 | 0.85 | 1.9 | 284 | 9.5 | – | 8436 0120 04 |
| ETV ES21-07-06 | 1/4 | 2.8-7 | 2.1-5.2 | 1147 | 0.85 | 1.9 | 284 | 9.5 | – | 8436 0120 07 |
| ETV ES21-12-06 | 1/4 | 4.8-12 | 3.5-8.9 | 718 | 0.95 | 2.1 | 304 | 11 | – | 8436 0120 12 |
| ETV ES21-20-10 | 3/8 | 8-20 | 5.9-14.8 | 430 | 1.05 | 2.3 | 303 | 14 | – | 8436 0120 20 |
| ETV ES61-25-10 | 3/8 | 10-25 | 7.4-18.4 | 1378 | 1.8 | 4.0 | 419 | 14 | – | 8436 0160 25 |
| ETV ES61-30-10 | 3/8 | 12-30 | 8.9-22.1 | 1160 | 1.8 | 4.0 | 421 | 15.5 | – | 8436 0160 30 |
| ETV ES61-40-10 | 3/8 | 16-40 | 11.8-29.5 | 1153 | 1.9 | 4.2 | 441 | 18 | – | 8436 0160 40 |
| ETV ES61-50-10 | 3/8 | 20-50 | 14.8-36.9 | 692 | 1.9 | 4.2 | 441 | 18 | – | 8436 0160 50 |
| ETV ES61-70-13 | 1/2 | 28-70 | 20.7-51.6 | 439 | 3.1 | 6.8 | 499 | 20 | – | 8436 0160 70 |
| ETV ES61-100-13 | 1/2 | 40-100 | 29.5-73.8 | 370 | 3.15 | 6.9 | 505 | 22.5 | – | 8436 0160 10 |
| ETV ES61-150-13 | 1/2 | 60-150 | 44.3-110.6 | 296 | 3.2 | 7.1 | 541 | 26 | – | 8436 0160 15 |
| ETV ES61-180-13 | 1/2 | 72-180 | 53-133 | 232 | 3.2 | 7.1 | 541 | 26 | – | 8436 0160 18 |
| ETV ES61-200-20 | 3/4 | 80-200 | 59-147.5 | 203 | 3.4 | 7.5 | 543 | 27 | – | 8436 0160 20 |
| Angle, quick chuck | | | | | | | | | | |
| ETV ES21-12-I06-QC | – | 4.8-12 | 3.5-8.9 | 718 | 0.95 | 2.1 | 304 | 11 | – | 8436 0121 12 |
| Angle, ball retainer | | | | | | | | | | |
| ETV ES61-70-B13 | 1/2 | 28-70 | 20.7-51.6 | 439 | 3.1 | 6.8 | 499 | 20 | – | 8436 0165 70 |
| ETV ES61-100-B13 | 1/2 | 40-100 | 29.5-73.8 | 370 | 3.15 | 6.9 | 505 | 22.5 | – | 8436 0165 10 |
| Straight models | | | | | | | | | | |
| ETD ES21-02-I06-PS | – | 0.8-2 | 0.6-1.5 | 4471 | 0.75 | 1.7 | 267 | 19.5 | – | 8436 0220 02 |
| ETD ES21-04-I06-PS | – | 1.6-4 | 1.2-3 | 1909 | 0.8 | 1.8 | 267 | 19.5 | – | 8436 0220 04 |
| ETD ES21-07-I06-PS | – | 2.8-7 | 2.1-5.2 | 1147 | 0.8 | 1.8 | 267 | 19.5 | – | 8436 0220 07 |
| ETD ES21-12-I06-PS | – | 4.8-12 | 3.5-8.9 | 745 | 0.8 | 1.8 | 267 | 19.5 | – | 8436 0220 12 |
| ETD ES61-18-10 | 3/8 | 7.2-18 | 5.3-13.3 | 2129 | 1.7 | 3.75 | 418 | 23 | -1 | 8436 0265 18 |
| ETD ES61-18-10-T25 | 3/8 | 7.2-18 | 5.3-13.3 | 2129 | 1.85 | 4.1 | 456 | 23 | 2/2 | 8436 0260 18 |
| ETD ES61-25-10 | 3/8 | 10-25 | 7.4-18.4 | 1793 | 1.7 | 3.8 | 418 | 23 | -1 | 8436 0265 25 |
| ETD ES61-25-10-T25 | 3/8 | 10-25 | 7.4-18.4 | 1793 | 1.85 | 4.1 | 456 | 23 | 2/2 | 8436 0260 25 |
| ETD ES61-30-10 | 3/8 | 12-30 | 8.9-22.1 | 1077 | 1.7 | 3.8 | 418 | 23 | -1 | 8436 0265 30 |
| ETD ES61-30-10-T25 | 3/8 | 12-30 | 8.9-22.1 | 1077 | 1.85 | 4.1 | 456 | 23 | 2/2 | 8436 0260 30 |
| ETD ES61-50-13 | 1/2 | 20-50 | 14.8-36.9 | 679 | 2.95 | 6.5 | 493 | 29 | 2/2 | 8436 0265 50 |
| ETD ES61-50-13-T25 | 1/2 | 20-50 | 14.8-36.9 | 679 | 3.05 | 6.7 | 521 | 29 | 3/5 | 8436 0260 50 |
| ETD ES61-70-13 | 1/2 | 28-70 | 20.7-51.6 | 608 | 2.95 | 6.5 | 493 | 29 | 2/2 | 8436 0265 70 |
| ETD ES61-70-13-T25 | 1/2 | 28-70 | 20.7-51.6 | 608 | 3.1 | 6.8 | 521 | 29 | 3/5 | 8436 0260 70 |
| ETD ES61-90-13 | 1/2 | 36-90 | 26.6-66.4 | 467 | 2.95 | 6.5 | 493 | 29 | 2/2 | 8436 0265 90 |
| ETD ES61-90-13-T25 | 1/2 | 36-90 | 26.6-66.4 | 467 | 3.1 | 6.8 | 521 | 29 | 3/5 | 8436 0260 90 |
| ETD ES61-120-13 | 1/2 | 48-120 | 35.4-88.5 | 365 | 2.95 | 6.5 | 493 | 29 | 2/2 | 8436 0265 12 |
| ETD ES61-120-13-T25 | 1/2 | 48-120 | 35.4-88.5 | 365 | 3.1 | 6.8 | 521 | 29 | 3/5 | 8436 0260 12 |
| Fixture models | | | | | | | | | | |
| ETF ES21-04-I06-T25 | – | 1.6-4 | 1.2-3 | 1909 | 0.96 | 2.1 | 338 | 22.5 | – ^a | 8436 0224 04 |
| ETF ES21-07-I06-T25 | – | 2.8-7 | 2.1-5.2 | 1147 | 0.96 | 2.1 | 338 | 22.5 | – ^a | 8436 0224 07 |
| ETF ES21-12-I06-T25 | – | 4.8-12 | 3.5-8.9 | 745 | 0.96 | 2.1 | 338 | 22.5 | – ^a | 8436 0224 12 |
| Pistol grip models | | | | | | | | | | |
| ETP ES21-02-I06-PS | – | 0.8-2 | 0.6-1.5 | 4471 | 0.85 | 1.87 | 225 | 19.5 | – | 8436 0320 02 |
| ETP ES21-04-I06-PS | – | 1.6-4 | 1.2-3 | 1909 | 0.85 | 1.87 | 225 | 19.5 | – | 8436 0320 04 |
| ETP ES21-07-I06-PS | – | 2.8-7 | 2.1-5.2 | 1147 | 0.85 | 1.87 | 225 | 19.5 | – | 8436 0320 07 |
| ETP ES21-12-I06-PS | – | 4.8-12 | 3.5-8.9 | 745 | 0.85 | 1.87 | 225 | 19.5 | – | 8436 0320 12 |

^a Mounting bracket fixed.

ETV DS

Tensor DS non-transducerized angle tool is equipped with spiral gears in the angle heads with improved contact ratio: This allows for smoother tightening and improved accuracy throughout the service life of the tool. The molded ergonomic motor sleeve improves grip and comfort for the operator.

- Angle tools are ideal for hand-held operations.
- Torque range from 40 to 4000 Nm.



ETV DS

| Model | Square drive in | Torque range | | Speed r/min | Weight | | Length mm | CS distance mm | Ordering No. |
|--------------------|--------------------|--------------|----------|----------------|--------|------|--------------|-------------------|--------------|
| | | Nm | ft lb | | kg | lb | | | |
| ETV DS72 | | | | | | | | | |
| ETV DS72-160-13 | 1/2 | 40-160 | 30-118 | 152 | 2.8 | 6.2 | 525 | 25.5 | 8433 1723 98 |
| ETV DS72-180-13 | 1/2 | 45-180 | 34-133 | 123 | 2.8 | 6.2 | 525 | 25.5 | 8433 1724 15 |
| ETV DS72-200-20 | 3/4 | 53-210 | 39-155 | 123 | 3.0 | 6.6 | 525 | 27 | 8433 1724 40 |
| ETV DS92 | | | | | | | | | |
| ETV DS92-180-13 | 1/2 | 45-180 | 34-113 | 395 | 3.8 | 8.4 | 578 | 25.5 | 8433 1750 68 |
| ETV DS92-270-20 | 3/4 | 70-270 | 52-199 | 240 | 7.0 | 15.4 | 661 | 33.5 | 8433 1751 38 |
| ETV DS92-370-20 | 3/4 | 95-370 | 70-273 | 152 | 7.1 | 15.7 | 661 | 33.5 | 8433 1751 86 |
| ETV DS92-450-20 | 3/4 | 115-450 | 85-333 | 131 | 11.6 | 25.6 | 702 | 54 | 8433 1752 04 |
| ETV DS92-600-25 | 1 | 150-600 | 111-444 | 112 | 11.6 | 25.6 | 702 | 54 | 8433 1752 63 |
| ETV DS92-600-20TM | 3/4 | 150-600 | 111-444 | 97 | 9.7 | 21.4 | 603 | 26.3 | 8433 1752 40 |
| ETV DS92-1000-25TM | 1 1/2 | 250-1000 | 185-740 | 60 | 12.0 | 26.5 | 666 | 32 | 8433 1752 90 |
| ETV DS92-2000-38TM | 1 1/2 | 500-2000 | 370-1480 | 30 | 17.0 | 37.5 | 706 | 63.5 | 8433 1752 96 |
| ETV DS92-4000-38TM | 1 1/2 | 1000-4000 | 740-2960 | 14 | 21.0 | 46.3 | 615 | 71 | 8433 1753 25 |

ETD DS

- ETD DS inline non-transducerized tools. The low torque series is ideal for hand-held bench assembly. The high torque tools are well suited for fixtured applications.
- Torque range from 21 to 3000 Nm.
- Telescopic spindles for fixtured applications.



ETD DS

| Model | Square drive in | Torque range | | Speed r/min | Weight | | Length mm | CS distance mm | Spline/ Mounting | Ordering No. |
|---------------------------|--------------------|--------------|----------|----------------|--------|------|--------------|-------------------|---------------------|--------------|
| | | Nm | ft lb | | kg | lb | | | | |
| ETD DS7 | | | | | | | | | | |
| ETD DS7-70-13S | 1/2 | 21-70 | 15-51 | 370 | 2.2 | 4.9 | 477 | 28 | 2 / 2 | 8433 0731 31 |
| ETD DS7-90-13S | 1/2 | 28-95 | 21-69 | 275 | 2.2 | 4.9 | 477 | 28 | 2 / 2 | 8433 0731 45 |
| ETD DS7-120-13S | 1/2 | 38-125 | 28-91 | 225 | 2.2 | 4.9 | 477 | 28 | 2 / 2 | 8433 0731 84 |
| ETD DS7 Telescopic | | | | | | | | | | |
| ETD DS7-70-13ST | 1/2 | 21-70 | 15-51 | 370 | 2.4 | 5.4 | 504 | 29.5 | 3 / 5 | 8433 0731 40 |
| ETD DS72-70-13ST75 | 1/2 | 21-70 | 15-51 | 370 | 2.5 | 5.5 | 645 | 29.5 | 3 / 5 | 8433 1731 39 |
| ETD DS7-90-13ST | 1/2 | 28-95 | 21-69 | 275 | 2.9 | 6.5 | 504 | 29.5 | 3 / 5 | 8433 0731 52 |
| ETD DS7-120-13ST | 1/2 | 38-125 | 28-91 | 225 | 3.0 | 6.6 | 504 | 29.5 | 3 / 5 | 8433 0731 96 |
| ETD DS7-120-13ST50 | 1/2 | 38-125 | 28-91 | 225 | 3.1 | 6.8 | 562 | 29.5 | 3 / 5 | 8433 0731 99 |
| ETD DS7-200-13ST | 1/2 | 50-200 | 37-146 | 225 | 3.2 | 7.1 | 616 | 29.5 | 3 / 5 | 8433 0732 10 |
| ETD DS9 | | | | | | | | | | |
| ETD DS9-100-13S | 1/2 | 40-100 | 29-73 | 715 | 3.0 | 6.7 | 529 | 32 | 2 / 2 | 8433 0756 42 |
| ETD DS9-150-13S | 1/2 | 60-150 | 44-110 | 455 | 3.2 | 7.1 | 544 | 32 | 2 / 2 | 8433 0757 54 |
| ETD DS9-200-13S | 1/2 | 80-200 | 58-146 | 340 | 3.2 | 7.1 | 544 | 32 | 2 / 2 | 8433 0758 71 |
| ETD DS9-270-20S | 3/4 | 68-270 | 50-199 | 220 | 6.2 | 14 | 603 | 36 | 6 / 8 | 8433 0760 53 |
| ETD DS9-450-20S | 3/4 | 115-450 | 85-328 | 125 | 7.4 | 16 | 639 | 40.5 | 6 / 8 | 8433 0760 71 |
| ETD DS9-1000-25S | 1 | 250-1000 | 184-730 | 68 | 12.3 | 27 | 769 | 47 | 7 / 11 | 8433 0763 60 |
| ETD DS9-1200-25S | 1 | 300-1200 | 220-880 | 55 | 12.3 | 27 | 769 | 47 | 7 / 11 | 8433 0763 80 |
| ETD DS9 Telescopic | | | | | | | | | | |
| ETD DS9-100-13ST | 1/2 | 40-100 | 29-73 | 715 | 3.2 | 7.1 | 557 | 32 | 3 / 5 | 8433 0756 92 |
| ETD DS9-150-13ST | 1/2 | 60-150 | 44-110 | 455 | 3.4 | 7.6 | 572 | 32 | 3 / 5 | 8433 0758 03 |
| ETD DS9-200-13ST | 1/2 | 80-200 | 58-146 | 340 | 3.4 | 7.6 | 572 | 32 | 3 / 5 | 8433 0759 11 |
| ETD DS9-270-20ST | 3/4 | 108-270 | 79-197 | 225 | 6.0 | 13 | 653 | 36 | 6 / 8 | 8433 0760 55 |
| ETD DS9-450-20ST | 3/4 | 115-450 | 85-328 | 125 | 7.6 | 17 | 689 | 40.5 | 6 / 8 | 8433 0760 88 |
| ETD DS9-600-20ST | 3/4 | 150-600 | 110-438 | 110 | 7.6 | 17 | 689 | 40.5 | 6 / 8 | 8433 0761 35 |
| ETD DS9-1000-25ST | 1 | 250-1000 | 184-730 | 68 | 12.5 | 28 | 824 | 47 | 7 / 11 | 8433 0763 63 |
| ETD DS9-1200-25ST | 1 | 300-1200 | 220-880 | 55 | 12.5 | 28 | 824 | 47 | 7 / 11 | 8433 0763 83 |
| ETD DS9-1500-38ST | 1 1/2 | 375-1500 | 280-1100 | 42 | 17 | 37.5 | 824 | 68 | 8 / 12 | 8433 0763 93 |
| ETD DS9-2000-38ST | 1 1/2 | 600-2000 | 440-1475 | 34 | 21 | 47 | 824 | 68 | 8 / 12 | 8433 0764 20 |
| ETD DS92-3000-38ST | 1 1/2 | 750-3000 | 550-2200 | 21 | 21.9 | 48.3 | 904 | 68 | 8 / 12 | 8433 1764 25 |

ETP DS

- ETP DS pistol grip tool for both hand-held and fixtured applications.
- Torque range from 2 to 4000 Nm.
- Telescopic spindles for fixtured applications.
- Swivelling front parts for easy positioning of reaction force.
- Female hex drives for bits.
- Swivelling tools are equipped with non-reversible start button, for operator safety.



| Model | Square drive in | Torque range | | Speed r/min | Weight | | Length mm | CS distance mm | Spine/ Mounting | Ordering No. |
|---------------------------------------|--------------------|--------------|----------|----------------|--------|------|--------------|-------------------|--------------------|--------------|
| | | Nm | ft lb | | kg | lb | | | | |
| ETP DS4 | | | | | | | | | | |
| ETP DS4-05-06S | 1/4 | 2-5 | 1.5-3.6 | 1310 | 1.1 | 2.5 | 193 | 21.5 | -/- | 8433 0708 76 |
| ETP DS4-10-06S | 1/4 | 3.5-12 | 2.5-8.8 | 660 | 1.1 | 2.5 | 193 | 21.5 | -/- | 8433 0708 92 |
| ETP DS42-10-10S | 3/8 | 3.5-12 | 2.5-8.8 | 905 | 1.0 | 2.2 | 188 | 21.3 | -/- | 8433 0709 11 |
| ETP DS4 Female Hex | | | | | | | | | | |
| ETP DS42-02-106 | 1/4 | 1.0-2.5 | 0.7-1.8 | 2950 | 0.9 | 2.0 | 188 | 21.3 | -/- | 8433 0708 40 |
| ETP DS42-05-106 | 1/4 | 2-5 | 1.5-3.6 | 1770 | 0.9 | 2.0 | 188 | 21.3 | -/- | 8433 0708 69 |
| ETP DS4-07-106S | 1/4 | 2.1-7 | 1.5-5.1 | 905 | 1.1 | 2.5 | 201 | 21.5 | -/- | 8433 0708 80 |
| ETP DS42-10-106 | 1/4 | 3.5-12 | 2.5-8.8 | 905 | 1.0 | 2.2 | 188 | 21.3 | -/- | 8433 0708 87 |
| ETP DS42-20-106 | 1/4 | 6-20 | 4.4-14.5 | 471 | 1.0 | 2.2 | 188 | 21.3 | -/- | 8433 0709 34 |
| ETP DS7 | | | | | | | | | | |
| ETP DS7-20-10S | 3/8 | 6-20 | 4.4-14.5 | 1240 | 1.6 | 3.6 | 273 | 21.5 | -/1 | 8433 0726 36 |
| ETP DS7-30-10S | 3/8 | 10-35 | 7.3-25 | 750 | 1.6 | 3.6 | 273 | 21.5 | -/1 | 8433 0726 53 |
| ETP DS7-50-13S | 1/2 | 17-55 | 12-40 | 540 | 1.9 | 4.2 | 318 | 21.5 | 2/2 | 8433 0726 87 |
| ETP DS7-70-13S | 1/2 | 21-70 | 15-51 | 370 | 2.1 | 4.7 | 340 | 21.5 | 2/2 | 8433 0727 01 |
| ETP DS7-90-13S | 1/2 | 28-95 | 21-69 | 275 | 2.1 | 4.7 | 340 | 21.5 | 2/2 | 8433 0727 19 |
| ETP DS7-120-13S | 1/2 | 38-125 | 28-91 | 220 | 2.1 | 4.7 | 340 | 21.5 | 2/2 | 8433 0727 47 |
| ETP DS7 Female Hex | | | | | | | | | | |
| ETP DS7-20-106 | 1/4 | 6-20 | 4.4-14.5 | 1240 | 1.6 | 3.6 | 273 | 21.5 | -/1 | 8433 0726 38 |
| ETP DS7 Swivelling^a | | | | | | | | | | |
| ETP DS7-70-13SSW | 1/2 | 21-70 | 15-51 | 370 | 2.2 | 4.9 | 339 | 29.5 | 2/4 | 8433 0727 09 |
| ETP DS7-90-13SSW | 1/2 | 28-95 | 21-69 | 275 | 2.2 | 4.9 | 339 | 29.5 | 2/4 | 8433 0727 28 |
| ETP DS7-120-13SSW | 1/2 | 38-125 | 28-91 | 220 | 2.2 | 4.9 | 339 | 29.5 | 2/4 | 8433 0727 84 |
| ETP DS9 | | | | | | | | | | |
| ETP DS9-100-13S | 1/2 | 40-100 | 29-73 | 790 | 3.8 | 8.5 | 378 | 32 | 2/2 | 8433 0765 39 |
| ETP DS9-150-13S | 1/2 | 60-150 | 44-110 | 510 | 3.8 | 8.5 | 392 | 32 | 2/2 | 8433 0765 58 |
| ETP DS9-200-13S | 1/2 | 80-200 | 58-146 | 375 | 3.8 | 8.5 | 392 | 32 | 2/2 | 8433 0766 05 |
| ETP DS9-270-20S | 3/4 | 108-270 | 79-197 | 250 | 5.8 | 12.9 | 451 | 36 | 6/8 | 8433 0766 49 |
| ETP DS9-450-20S | 3/4 | 115-450 | 85-328 | 140 | 7.4 | 16.5 | 487 | 40.5 | 6/8 | 8433 0767 52 |
| ETP DS9-600-20S | 3/4 | 150-600 | 110-438 | 120 | 7.4 | 16.5 | 487 | 40.5 | 6/8 | 8433 0768 08 |
| ETP DS9-1000-25S | 1 | 250-1000 | 184-730 | 68 | 12.1 | 26.7 | 620 | 47 | 7/11 | 8433 0768 66 |
| ETP DS9-4000-38S | 1 1/2 | 1000-4000 | 730-2950 | 17 | 21.7 | 47.8 | 654 | 68 | 8/12 | 8433 0769 50 |
| ETP DS9 Telescopic | | | | | | | | | | |
| ETP DS9-1000-25ST | 1 | 250-1000 | 184-730 | 68 | 12.3 | 27.1 | 672 | 47 | 7/11 | 8433 0768 79 |
| ETP DS9-2000-38ST | 1 1/2 | 500-2000 | 440-1475 | 34 | 17 | 37.5 | 672 | 68 | 8/12 | 8433 0769 20 |
| ETP DS9-4000-38ST | 1 1/2 | 1000-4000 | 730-2950 | 17 | 21.9 | 48.3 | 753 | 68 | 8/12 | 8433 0769 60 |
| ETP DS9 Swivelling^a | | | | | | | | | | |
| ETP DS9-150-13SSW | 1/2 | 60-150 | 44-110 | 510 | 3.9 | 8.7 | 394 | 32 | 2/4 | 8433 0765 69 |
| ETP DS9-200-13SSW | 1/2 | 80-200 | 58-146 | 375 | 3.9 | 8.7 | 394 | 32 | 2/4 | 8433 0766 12 |
| ETP DS9-350-20SSW | 3/4 | 100-370 | 75-270 | 180 | 5.2 | 11.5 | 387 | 35 | 4 | 8433 0766 56 |
| ETP DS9-500-20SSW | 3/4 | 140-530 | 105-390 | 125 | 5.2 | 11.5 | 387 | 35 | 4 | 8433 0767 71 |
| ETP DS9-750-25SSW | 1 | 220-750 | 162-553 | 84 | 5.5 | 12.1 | 428 | 47 | 5 | 8433 0768 24 |
| ETP DS9-1000-25SSW | 1 | 250-1000 | 184-730 | 68 | 12.1 | 26.7 | 620 | 47 | 7/11 | 8433 0768 76 |
| ETP DS9-1500-25SSW | 1 | 375-1500 | 280-1100 | 45 | 8.5 | 18.8 | 450 | 46 | 9 | 8433 0768 99 |
| ETP DS9-2000-38SSW | 1 1/2 | 500-2000 | 440-1475 | 34 | 16.8 | 37 | 574 | 68 | 8/12 | 8433 0769 15 |

^a Non-reversible start button as standard.

ETV ST

- ETV ST right angle tools are ideal for hand-held and fixtured applications.
- Torque range from 1 to 4000 Nm.
- Tensor ST offers:
 - Extremely high productivity.
 - Ergonomic design.
 - Excellent operator feedback.
- The ETV ST ATEX tools are certified to be used in environments with hazardous gases and liquids.



ETV ST

| Model | Square drive in | Torque range | | Speed r/min | Weight | | Length mm | CS distance mm | Height mm | Ordering No. |
|-------------------------------|--------------------|--------------|----------|----------------|--------|-----|--------------|-------------------|--------------|--------------|
| | | Nm | ft lb | | kg | lb | | | | |
| ETV ST31 | | | | | | | | | | |
| ETV ST31-05-10 | 3/8 | 1-5 | 0.7-3.6 | 2390 | 1.0 | 2.2 | 381 | 11 | 39 | 8433 2011 21 |
| ETV ST31-10-10 | 3/8 | 3-12 | 2.2-8.8 | 1020 | 1.0 | 2.2 | 381 | 11 | 39 | 8433 2013 66 |
| ETV ST31-15-10 | 3/8 | 5-15 | 3.6-10 | 755 | 1.0 | 2.2 | 381 | 11 | 39 | 8433 2015 98 |
| ETV ST31-20-10 | 3/8 | 5-22 | 3.7-16.1 | 545 | 1.2 | 2.6 | 415 | 14 | 42 | 8433 2017 10 |
| ETV ST31 Female Hex | | | | | | | | | | |
| ETV ST31-05-I06-QC | – | 1-5 | 0.7-3.6 | 2390 | 1.0 | 2.2 | 381 | 11 | 39 | 8433 2011 95 |
| ETV ST31-10-I06-QC | – | 3-12 | 2.2-8.8 | 1020 | 1.0 | 2.2 | 381 | 11 | 39 | 8433 2014 21 |
| ETV ST61 | | | | | | | | | | |
| ETV ST61-28-10 | 3/8 | 6-29 | 4-21 | 1450 | 1.3 | 2.9 | 440 | 14 | 42 | 8433 2021 76 |
| ETV ST61-30-10 | 3/8 | 7-35 | 5-25 | 1090 | 1.3 | 2.9 | 440 | 15.5 | 42 | 8433 2023 92 |
| ETV ST61-40-10 | 3/8 | 8-40 | 6-29 | 1090 | 1.5 | 3.3 | 454 | 18 | 47 | 8433 2027 85 |
| ETV ST61-50-10 | 3/8 | 10-55 | 7-40 | 655 | 1.5 | 3.3 | 454 | 18 | 47 | 8433 2031 58 |
| ETV ST61-70-13 | 1/2 | 15-80 | 10-58 | 475 | 2.0 | 4.5 | 466 | 20 | 58 | 8433 2035 30 |
| ETV ST61-100-13 | 1/2 | 20-100 | 15-80 | 350 | 2.5 | 5.5 | 502 | 22.5 | 60 | 8433 2039 02 |
| ETV ST61-150-13 | 1/2 | 30-160 | 22-117 | 227 | 3.0 | 6.6 | 536 | 25.5 | 65 | 8433 2042 70 |
| ETV ST61-180-13 | 1/2 | 35-180 | 26-133 | 190 | 3.0 | 6.6 | 536 | 25.5 | 65 | 8433 2045 53 |
| ETV ST61-200-20 | 3/4 | 40-200 | 30-154 | 185 | 3.0 | 6.6 | 537 | 27 | 70 | 8433 2046 39 |
| ETV ST61 ATEX | | | | | | | | | | |
| ETV ST61-28-10-ATEX | 3/8 | 6-29 | 4-21 | 1450 | 1.3 | 2.9 | 440 | 14 | 42 | 8433 2023 76 |
| ETV ST61-40-10-ATEX | 3/8 | 8-40 | 6-29 | 1090 | 1.5 | 3.3 | 454 | 18 | 47 | 8433 2030 85 |
| ETV ST61-50-10-ATEX | 3/8 | 10-55 | 7-40 | 655 | 1.5 | 3.3 | 454 | 18 | 47 | 8433 2034 98 |
| ETV ST61-70-13-ATEX | 1/2 | 15-80 | 10-58 | 475 | 2.0 | 4.5 | 466 | 20 | 58 | 8433 2037 90 |
| ETV ST61-100-13-ATEX | 1/2 | 20-100 | 15-80 | 350 | 2.5 | 5.5 | 502 | 22.5 | 60 | 8433 2041 42 |
| ETV ST61-150-13-ATEX | 1/2 | 30-160 | 22-117 | 230 | 3.0 | 6.6 | 536 | 25.5 | 65 | 8433 2045 20 |
| ETV ST61-200-20-ATEX | 3/4 | 40-200 | 30-154 | 185 | 3.0 | 6.6 | 537 | 27 | 70 | 8433 2048 49 |
| ETV ST61 Ball Retainer | | | | | | | | | | |
| ETV ST61-70-B13 | 1/2 | 15-80 | 10-58 | 475 | 2.0 | 4.5 | 466 | 20 | 60 | 8433 2036 93 |
| ETV ST61-100-B13 | 1/2 | 20-100 | 15-80 | 350 | 2.5 | 5.5 | 502 | 22.5 | 58 | 8433 2040 70 |
| ETV ST61-150-B13 | 1/2 | 30-160 | 22-117 | 230 | 3.0 | 6.6 | 536 | 25.5 | 65 | 8433 2043 62 |
| ETV ST61-180-B13 | 1/2 | 35-180 | 26-133 | 190 | 3.0 | 6.6 | 536 | 25.5 | 65 | 8433 2045 61 |
| ETV ST61 Flush Socket | | | | | | | | | | |
| ETV ST61-30-FS | - | 7-35 | 5-25 | 1090 | 1.3 | 2.9 | 440 | 16 | 32 | 8433 2025 50 |
| ETV ST61-40-FS | - | 8-40 | 6-29 | 1090 | 1.5 | 3.3 | 454 | 18 | 39 | 8433 2029 50 |
| ETV ST61-50-FS | - | 10-55 | 7-40 | 655 | 1.5 | 3.3 | 454 | 18 | 39 | 8433 2033 15 |
| ETV ST61-70-FS | - | 15-80 | 10-58 | 475 | 2.0 | 4.5 | 466 | 20 | 50 | 8433 2037 36 |
| ETV ST61-100-FS | - | 20-110 | 15-80 | 350 | 2.5 | 5.5 | 502 | 23 | 51 | 8433 2040 75 |
| ETV ST61-150-FS | - | 30-160 | 22-117 | 220 | 3.0 | 6.6 | 539 | 26 | 58 | 8433 2044 14 |
| ETV ST61-180-FS | - | 35-180 | 26-133 | 190 | 3.0 | 6.6 | 539 | 26 | 58 | 8433 2045 72 |
| ETV ST61-200-FS | - | 40-200 | 30-154 | 185 | 3.0 | 6.6 | 541 | 27 | 58 | 8433 2047 21 |

Continued...

| Model | Square drive in | Torque range | | Speed r/min | Weight | | Length mm | CS distance mm | Height mm | Ordering No. |
|--|--------------------|--------------|----------|----------------|--------|------|--------------|-------------------|--------------|--------------|
| | | Nm | ft lb | | kg | lb | | | | |
| ETV ST61 Hold & Drive | | | | | | | | | | |
| ETV ST61-28-HAD | - | 6-29 | 4-21 | 1450 | 1.9 | 4.2 | 463 | 18.3 | 62 | 8433 2023 21 |
| ETV ST61-50-HAD | - | 10-55 | 7-40 | 655 | 2.0 | 4.4 | 440 | 18.3 | 80 | 8433 2033 92 |
| ETV ST61-100-HAD | - | 20-100 | 15-80 | 350 | 2.6 | 5.7 | 504 | 23 | 71 | 8433 2038 36 |
| ETV ST61-100-HAD-HD | - | 20-100 | 15-80 | 350 | 2.6 | 5.7 | 539 | 26 | 80 | 8433 2038 35 |
| ETV ST61-120-HAD | - | 30-130 | 22-100 | 350 | 2.6 | 5.5 | 540 | 26 | 80 | 8433 2041 53 |
| ETV ST61-150-HAD | - | 30-160 | 22-117 | 220 | 3.1 | 6.6 | 540 | 26 | 80 | 8433 2044 80 |
| ETV ST61-180-HAD | - | 35-180 | 26-133 | 190 | 3.1 | 6.6 | 540 | 26 | 80 | 8433 2045 80 |
| ETV ST61-200-HAD | - | 40-200 | 30-154 | 185 | 3.1 | 6.6 | 541 | 26 | 80 | 8433 2048 27 |
| ETV ST61 with Barcode Scanner | | | | | | | | | | |
| ETV ST61-30-10-BCR | 3/8 | 7-35 | 5-25 | 1090 | 1.4 | 3.2 | 440 | 15.5 | 42 | 8433 2026 66 |
| ETV ST61-50-10-BCR | 3/8 | 10-55 | 7-40 | 655 | 1.6 | 3.6 | 454 | 18 | 47 | 8433 2034 67 |
| ETV ST81 | | | | | | | | | | |
| ETV ST81-50-10 | 3/8 | 16-55 | 12-40 | 1090 | 1.8 | 3.9 | 473 | 18 | 48 | 8433 2051 55 |
| ETV ST81-70-13 | 1/2 | 20-80 | 15-58 | 790 | 2.3 | 5.0 | 485 | 20 | 58 | 8433 2053 48 |
| ETV ST81-100-13 | 1/2 | 20-100 | 15-80 | 540 | 2.7 | 5.9 | 522 | 22.5 | 60 | 8433 2056 82 |
| ETV ST81-150-13 | 1/2 | 30-160 | 22-117 | 380 | 3.2 | 7.0 | 555 | 26 | 65 | 8433 2060 12 |
| ETV ST81-180-13 | 1/2 | 35-180 | 26-133 | 310 | 3.2 | 7.0 | 555 | 26 | 65 | 8433 2062 31 |
| ETV ST81-200-20 | 3/4 | 40-200 | 30-154 | 300 | 3.2 | 7.0 | 556 | 27 | 70 | 8433 2063 42 |
| ETV ST81 Ball Retainer | | | | | | | | | | |
| ETV ST81-70-B13 | 1/2 | 20-80 | 15-58 | 790 | 2.3 | 5.0 | 485 | 20 | 58 | 8433 2054 62 |
| ETV ST81-100-B13 | 1/2 | 20-100 | 15-80 | 540 | 2.7 | 5.9 | 522 | 22.5 | 60 | 8433 2058 24 |
| ETV ST81-150-B13 | 1/2 | 30-160 | 22-117 | 380 | 3.3 | 7.0 | 555 | 25.5 | 65 | 8433 2060 97 |
| ETV ST81-180-B13 | 1/2 | 35-180 | 26-133 | 310 | 3.2 | 7.0 | 555 | 25.5 | 65 | 8433 2062 43 |
| ETV ST81 Flush Socket | | | | | | | | | | |
| ETV ST81-100-FS | - | 20-100 | 15-80 | 540 | 2.7 | 5.9 | 522 | 23 | 51 | 8433 2058 68 |
| ETV ST81-180-FS | - | 35-180 | 26-133 | 310 | 3.2 | 7.0 | 555 | 26 | 58 | 8433 2062 50 |
| ETV ST81-200-FS | - | 40-200 | 30-154 | 300 | 3.2 | 7.0 | 557 | 28 | 58 | 8433 2064 59 |
| ETV ST81 Hold & Drive | | | | | | | | | | |
| ETV ST81-50-HAD | - | 16-55 | 12-40 | 1090 | 2.3 | 5.0 | 473 | 18.5 | 62 | 8433 2052 80 |
| ETV ST81-100-HAD | - | 20-100 | 15-80 | 665 | 2.6 | 5.7 | 542 | 23 | 71 | 8433 2056 36 |
| ETV ST81-100-HAD-HD | - | 20-100 | 15-80 | 665 | 2.7 | 5.9 | 542 | 26 | 80 | 8433 2056 35 |
| ETV ST81-120-HAD | - | 30-130 | 22-100 | 540 | 2.8 | 6.0 | 560 | 26 | 80 | 8433 2058 65 |
| ETV ST81-150-HAD | - | 30-160 | 22-117 | 365 | 3.3 | 7.0 | 560 | 26 | 80 | 8433 2061 81 |
| ETV ST81-180-HAD | - | 35-180 | 26-133 | 310 | 3.3 | 7.0 | 560 | 26 | 80 | 8433 2062 60 |
| ETV ST81-200-HAD | - | 40-200 | 30-154 | 300 | 3.3 | 7.0 | 561 | 28 | 81 | 8433 2065 09 |
| ETV ST101 | | | | | | | | | | |
| ETV ST101-100-13 | 1/2 | 20-100 | 15-74 | 920 | 4.2 | 9.3 | 572 | 22.5 | 44 | 8433 2080 10 |
| ETV ST101-180-13 | 1/2 | 50-180 | 37-133 | 575 | 4.2 | 9.3 | 600 | 25.3 | 47 | 8433 2080 52 |
| ETV ST101-200-20 | 3/4 | 50-200 | 37-147 | 485 | 4.4 | 9.7 | 602 | 27.5 | 47 | 8433 2080 92 |
| ETV ST101-270-20 | 3/4 | 65-270 | 48-199 | 380 | 7.3 | 16.1 | 672 | 32.9 | 62 | 8433 2081 23 |
| ETV ST101-370-20 | 3/4 | 90-370 | 66-273 | 280 | 7.3 | 16.1 | 672 | 32.9 | 62 | 8433 2082 26 |
| ETV ST101-450-20 | 3/4 | 110-450 | 81-332 | 230 | 10.6 | 23.4 | 715 | 54.0 | 76 | 8433 2082 81 |
| ETV ST101-600-25 | 1 | 150-600 | 111-443 | 151 | 10.6 | 23.4 | 715 | 54.0 | 76 | 8433 2083 56 |
| ETV ST101 Fan | | | | | | | | | | |
| ETV ST101-100-13-F | 1/2 | 20-100 | 15-74 | 920 | 4.2 | 9.3 | 572 | 23 | 44 | 8433 2080 30 |
| ETV ST101-180-13-F | 1/2 | 50-180 | 37-133 | 575 | 4.2 | 9.3 | 600 | 25 | 47 | 8433 2080 63 |
| ETV ST101-200-20-F | 3/4 | 50-200 | 37-147 | 485 | 4.4 | 9.7 | 602 | 28 | 47 | 8433 2080 93 |
| ETV ST101-270-20-F | 3/4 | 65-270 | 48-199 | 380 | 7.3 | 16.1 | 672 | 33 | 62 | 8433 2081 45 |
| ETV ST101-370-20-F | 3/4 | 90-370 | 66-273 | 280 | 7.3 | 16.1 | 672 | 33 | 62 | 8433 2082 48 |
| ETV ST101-450-20-F | 3/4 | 110-450 | 81-332 | 230 | 10.6 | 23.4 | 715 | 54 | 76 | 8433 2082 90 |
| ETV ST101-600-25-F | 1 | 150-600 | 111-443 | 150 | 10.6 | 23.4 | 715 | 54 | 76 | 8433 2083 69 |
| ETV ST101 Torque Multiplier | | | | | | | | | | |
| ETV ST101-600-TM | 3/4 | 150-600 | 111-443 | 132 | 7.6 | 16.8 | 613 | 34 | 143 | 8433 2083 62 |
| ETV ST101-1000-TM | 1 | 250-1000 | 184-734 | 77 | 11.3 | 24.3 | 679 | 40 | 191 | 8433 2084 05 |
| ETV ST101-1500-25-TM | 1 | 325-1500 | 240-1100 | 23 | 12 | 26 | 625 | 43 | 257 | 8433 2084 65 |
| ETV ST101-1500-38-TM | 1 1/2 | 325-1500 | 240-1100 | 48 | 19 | 42 | 719 | 71 | 233 | 8433 2084 70 |
| ETV ST101-2000-38-TM | 1 1/2 | 500-2000 | 370-1475 | 35 | 19 | 42 | 719 | 71 | 231 | 8433 2084 80 |
| ETV ST101-4000-38-TM | 1 1/2 | 1000-4000 | 734-2950 | 21.8 | 21.5 | 47 | 710 | 71 | 350 | 8433 2084 90 |
| ETV ST101 Torque Multiplier/Fan | | | | | | | | | | |
| ETV ST101-600-TM-F | 3/4 | 150-600 | 111-443 | 132 | 7.6 | 16.8 | 613 | 34 | 143 | 8433 2083 96 |
| ETV ST101-1000-TM-F | 1 | 250-1000 | 184-734 | 77 | 11.3 | 24.3 | 679 | 40 | 191 | 8433 2084 10 |

ETD ST

- ETD ST inline tools.
- Torque range from 1 to 4000 Nm.
- Tensor ST offers:
 - Extremely high productivity.
 - Ergonomic design.
 - Excellent operator feedback.



ETD ST

| Model | Square drive in | Torque range | | Speed r/min | Weight | | Length mm | CS distance mm | Spline/ Mounting | Ordering No. |
|--|--------------------|--------------|---------|----------------|--------|-----|--------------|-------------------|---------------------|--------------|
| | | Nm | ft lb | | kg | lb | | | | |
| ETD ST31 | | | | | | | | | | |
| ETD ST31-05-10 | 3/8 | 1-5 | 1.1-3.6 | 2825 | 0.9 | 2.0 | 388 | 24 | - / 1 | 8433 2112 42 |
| ETD ST31-10-10 | 3/8 | 2-10 | 2.2-7.2 | 1200 | 1.1 | 2.4 | 388 | 24 | - / 1 | 8433 2114 86 |
| ETD ST31 Telescopic | | | | | | | | | | |
| ETD ST31-05-10-T25 | 3/8 | 1-5 | 1.1-3.6 | 2825 | 0.9 | 2.0 | 437 | 24 | - / 13 | 8433 2111 34 |
| ETD ST31-10-10-T25 | 3/8 | 2-10 | 2.2-7.2 | 1200 | 1.1 | 2.4 | 437 | 24 | - / 13 | 8433 2113 79 |
| ETD ST31 Ball Retainer Telescopic | | | | | | | | | | |
| ETD ST31-05-B10-T25 | 3/8 | 1-5 | 1.1-3.6 | 2825 | 1.1 | 2.4 | 437 | 24 | - / 13 | 8433 2113 44 |
| ETD ST31 Female Hex | | | | | | | | | | |
| ETD ST31-05-I06 | 1/4 | 1-5 | 1.1-3.6 | 2825 | 0.9 | 2.0 | 350 | 24 | - / 14 | 8433 2112 87 |
| ETD ST61 | | | | | | | | | | |
| ETD ST61-15-10 | 3/8 | 4-16 | 3-12 | 2250 | 1.4 | 3.1 | 438 | 24 | - / 1 | 8433 2120 91 |
| ETD ST61-20-10 | 3/8 | 5-22 | 3.6-16 | 1700 | 1.4 | 3.1 | 438 | 24 | - / 1 | 8433 2122 62 |
| ETD ST61-30-10 | 3/8 | 6-35 | 4.4-25 | 1020 | 1.4 | 3.1 | 429 | 24 | - / 1 | 8433 2125 06 |
| ETD ST61-50-13 | 1/2 | 10-55 | 7.3-40 | 740 | 1.9 | 4.2 | 474 | 24 | 2 / 2 | 8433 2128 79 |
| ETD ST61-70-13 | 1/2 | 15-80 | 12-58 | 505 | 2.3 | 5.0 | 491 | 26.5 | 2 / 2 | 8433 2132 51 |
| ETD ST61-90-13 | 1/2 | 20-95 | 15-70 | 410 | 2.3 | 5.0 | 491 | 26.5 | 2 / 2 | 8433 2136 22 |
| ETD ST61 Telescopic | | | | | | | | | | |
| ETD ST61-15-10-T25 | 3/8 | 4-16 | 3-12 | 2250 | 1.5 | 3.3 | 477 | 24 | 2 / 2 | 8433 2120 43 |
| ETD ST61-20-10-T25 | 3/8 | 5-20 | 3.6-15 | 1700 | 1.5 | 3.3 | 477 | 24 | 2 / 2 | 8433 2121 55 |
| ETD ST61-30-10-T25 | 3/8 | 6-35 | 4.4-25 | 1020 | 1.5 | 3.3 | 468 | 24 | 2 / 2 | 8433 2123 80 |
| ETD ST61-50-13-T25 | 1/2 | 10-55 | 7.3-40 | 740 | 2.1 | 4.6 | 501 | 24 | 3 / 5 | 8433 2127 54 |
| ETD ST61-70-13-T25 | 1/2 | 15-80 | 12-58 | 505 | 2.4 | 5.4 | 518 | 26.5 | 3 / 5 | 8433 2131 27 |
| ETD ST61-90-13-T25 | 1/2 | 20-95 | 15-70 | 410 | 2.4 | 5.4 | 518 | 26.5 | 3 / 5 | 8433 2134 99 |
| ETD ST61-120-13-T25 | 1/2 | 25-125 | 19-95 | 305 | 2.4 | 5.4 | 518 | 26.5 | 3 / 5 | 8433 2138 68 |
| ETD ST61 Female Hex | | | | | | | | | | |
| ETD ST61-15-I06 | 1/4 | 4-16 | 3-12 | 2250 | 1.4 | 3.1 | 430 | 24 | - / 1 | 8433 2121 36 |
| ETD ST81 | | | | | | | | | | |
| ETD ST81-30-10 | 3/8 | 10-30 | 7-22 | 1700 | 1.8 | 4.0 | 450 | 24 | - / 1 | 8433 2151 93 |
| ETD ST81-50-13 | 1/2 | 16-50 | 12-37 | 1230 | 2.1 | 4.6 | 493 | 24 | 2 / 2 | 8433 2153 34 |
| ETD ST81-70-13 | 1/2 | 15-70 | 12-51 | 880 | 2.5 | 5.5 | 510 | 26.5 | 2 / 2 | 8433 2156 03 |
| ETD ST81-90-13 | 1/2 | 20-95 | 15-70 | 675 | 2.5 | 5.5 | 510 | 26.5 | 2 / 2 | 8433 2158 14 |
| ETD ST81-120-13 | 1/2 | 25-125 | 19-91 | 505 | 2.5 | 5.5 | 510 | 26.5 | 2 / 2 | 8433 2160 25 |
| ETD ST81 Telescopic | | | | | | | | | | |
| ETD ST81-70-13-T25 | 1/2 | 15-70 | 12-51 | 880 | 2.6 | 5.8 | 538 | 26.5 | 3 / 5 | 8433 2154 98 |
| ETD ST81-90-13-T25 | 1/2 | 20-95 | 15-70 | 675 | 2.6 | 5.8 | 538 | 26.5 | 3 / 5 | 8433 2157 25 |
| ETD ST81-120-13-T25 | 1/2 | 25-125 | 19-91 | 505 | 2.6 | 5.8 | 538 | 26.5 | 3 / 5 | 8433 2159 53 |

Continued...

| Model | Square drive in | Torque range | | Speed r/min | Weight | | Length mm | CS distance mm | Spline/ Mounting | Ordering No. |
|---------------------------------|--------------------|--------------|----------|----------------|--------|------|--------------|-------------------|---------------------|--------------|
| | | Nm | ft lb | | kg | lb | | | | |
| ETD ST101 | | | | | | | | | | |
| ETD ST101-100-13 | 1/2 | 25-100 | 18-73 | 1043 | 3.2 | 7.0 | 631 | 30.5 | - | 8433 2179 00 |
| ETD ST101-120-13 | 1/2 | 30-120 | 22-88 | 875 | 3.2 | 7.0 | 631 | 30.5 | - | 8433 2180 22 |
| ETD ST101-150-20 | 3/4 | 30-150 | 22-109 | 685 | 4.3 | 9.3 | 706 | 33 | - | 8433 2181 36 |
| ETD ST101-200-20 | 3/4 | 50-200 | 36-146 | 500 | 7.4 | 16.3 | 706 | 33 | - | 8433 2182 05 |
| ETD ST101-300-20 | 3/4 | 70-300 | 51-221 | 345 | 7.4 | 16.3 | 706 | 33 | - | 8433 2182 70 |
| ETD ST101-500-20 | 3/4 | 120-500 | 88-368 | 204 | 8.3 | 18.5 | 717 | 33 | - | 8433 2183 28 |
| ETD ST101-750-25 | 1 | 150-750 | 109-553 | 143 | 9.1 | 20.3 | 681 | 45 | - | 8433 2184 40 |
| ETD ST101-1000-25 | 1 | 250-1000 | 184-737 | 100 | 9.7 | 21.6 | 708 | 45 | - | 8433 2185 60 |
| ETD ST101-1200-25-S | 1 | 300-1200 | 220-885 | 81 | 12 | 26 | 787 | 47 | 7 | 8433 2196 10 |
| ETD ST101 Fan | | | | | | | | | | |
| ETD ST101-100-13-F | 1/2 | 25-100 | 18-73 | 1043 | 3.2 | 7.0 | 631 | 30.5 | - | 8433 2179 05 |
| ETD ST101-150-20-F | 3/4 | 30-150 | 22-109 | 685 | 4.3 | 9.3 | 706 | 33 | - | 8433 2181 40 |
| ETD ST101-200-20-F | 3/4 | 50-200 | 36-146 | 500 | 7.4 | 16.3 | 706 | 33 | - | 8433 2182 10 |
| ETD ST101-300-20-F | 3/4 | 70-300 | 51-221 | 345 | 7.4 | 16.3 | 706 | 33 | - | 8433 2182 72 |
| ETD ST101-500-20-F | 3/4 | 120-500 | 88-368 | 204 | 8.3 | 18.5 | 717 | 33 | - | 8433 2183 30 |
| ETD ST101-750-25-F | 1 | 150-750 | 109-553 | 143 | 9.1 | 20.3 | 681 | 45 | - | 8433 2184 50 |
| ETD ST101-1200-25-F | 1 | 300-1200 | 220-885 | 81 | 12 | 26 | 787 | 47 | - | 8433 2186 10 |
| ETD ST101-2000-38-F | 1 1/2 | 500-2000 | 370-1475 | 48 | 17 | 37 | 742 | 68 | - | 8433 2187 22 |
| ETD ST101-2000-38-S-F | 1 1/2 | 500-2000 | 370-1475 | 48 | 17 | 37 | 742 | 68 | 8 | 8433 2197 22 |
| ETD ST101-4000-38-F | 1 1/2 | 1000-4000 | 735-2950 | 25 | 22 | 48 | 823 | 68 | - | 8433 2187 40 |
| ETD ST101-4000-38-S-F | 1 1/2 | 1000-4000 | 735-2950 | 25 | 22 | 48 | 823 | 68 | 8 | 8433 2197 40 |
| ETD ST101 Telescopic | | | | | | | | | | |
| ETD ST101-100-13-T25 | 1/2 | 25-100 | 18-73 | 1043 | 3.3 | 7.3 | 656 | 30.5 | - | 8433 2179 10 |
| ETD ST101-120-13-T25 | 1/2 | 30-120 | 22-88 | 873 | 3.3 | 7.3 | 656 | 30.5 | - | 8433 2180 32 |
| ETD ST101-150-20-T40 | 3/4 | 30-150 | 22-109 | 685 | 4.4 | 9.7 | 656 | 30.5 | - | 8433 2181 46 |
| ETD ST101-200-20-T40 | 3/4 | 50-200 | 36-146 | 500 | 7.5 | 16.5 | 756 | 33 | - | 8433 2182 23 |
| ETD ST101-300-20-T40 | 3/4 | 70-300 | 51-221 | 345 | 7.5 | 16.5 | 756 | 33 | - | 8433 2182 82 |
| ETD ST101-500-20-T40 | 3/4 | 120-500 | 88-368 | 204 | 8.4 | 18.5 | 768 | 37 | - | 8433 2183 38 |
| ETD ST101-750-25-T50 | 1 | 150-750 | 109-553 | 143 | 9.2 | 20.3 | 727 | 45 | - | 8433 2184 56 |
| ETD ST101-1000-25-T50 | 1 | 250-1000 | 184-737 | 100 | 9.8 | 21.6 | 754 | 45 | - | 8433 2185 78 |
| ETD ST101 Telescopic Fan | | | | | | | | | | |
| ETD ST101-100-13-T25-F | 1/2 | 25-100 | 18-73 | 1043 | 3.3 | 7.3 | 656 | 30.5 | - | 8433 2179 15 |
| ETD ST101-120-13-T25-F | 1/2 | 30-120 | 22-88 | 873 | 3.3 | 7.3 | 656 | 30.5 | - | 8433 2180 48 |
| ETD ST101-150-20-T40-F | 3/4 | 30-150 | 22-109 | 685 | 4.4 | 9.7 | 656 | 30.5 | - | 8433 2181 59 |
| ETD ST101-200-20-T40-F | 3/4 | 50-200 | 36-146 | 500 | 7.5 | 16.5 | 756 | 33 | - | 8433 2182 45 |
| ETD ST101-300-20-T40-F | 3/4 | 70-300 | 51-221 | 345 | 7.5 | 16.5 | 756 | 33 | - | 8433 2182 91 |
| ETD ST101-500-20-T40-F | 3/4 | 120-500 | 88-368 | 204 | 8.4 | 18.5 | 769 | 37 | - | 8433 2183 49 |
| ETD ST101-750-25-T50-F | 1 | 150-750 | 109-553 | 143 | 9.2 | 20.3 | 769 | 45 | - | 8433 2184 69 |
| ETD ST101-1000-25-T50-F | 1 | 250-1000 | 184-737 | 100 | 9.8 | 21.6 | 755 | 45 | - | 8433 2185 89 |
| ETD ST101-1200-25-T50-F | 1 | 300-1200 | 220-885 | 81 | 12 | 26 | 844 | 47 | - | 8433 2186 12 |
| ETD ST101-1200-25-T50-S-F | 1 | 300-1200 | 220-885 | 81 | 12 | 26 | 844 | 47 | 7 | 8433 2196 12 |
| ETD ST101-2000-38-T50-F | 1 1/2 | 500-2000 | 370-1475 | 48 | 17 | 37 | 840 | 68 | - | 8433 2187 20 |
| ETD ST101-2000-38-T50-S-F | 1 1/2 | 500-2000 | 370-1475 | 48 | 17 | 37 | 840 | 68 | 8 | 8433 2197 20 |
| ETD ST101-4000-38-T50-F | 1 1/2 | 1000-4000 | 735-2950 | 25 | 22 | 48 | 921 | 68 | - | 8433 2187 42 |
| ETD ST101-4000-38-T50-S-F | 1 1/2 | 1000-4000 | 735-2950 | 25 | 22 | 48 | 921 | 68 | 8 | 8433 2197 42 |

ETP ST

- ETP ST is a pistol grip model for hand-held applications.
- Torque range from 1 to 20 Nm.
- Female hex drive for bits.
- Low weight and ergonomic grip.
- Easy to access, reverse button.
- Operator friendly, feedback signals with sound and lights.



ETP ST

| Model | Square drive in | Torque range | | Speed r/min | Weight | | Length mm | Height mm | Ordering No. |
|--------------------------------------|--------------------|--------------|----------|----------------|--------|-----|--------------|--------------|--------------|
| | | Nm | ft lb | | kg | lb | | | |
| ETP ST32 | | | | | | | | | |
| ETP ST32-05-10 | 3/8 | 1-5 | 0.7-3.6 | 2820 | 0.75 | 1.7 | 197 | 179 | 8433 2211 03 |
| ETP ST32-05-I06 | - | 1-5 | 0.7-3.6 | 2820 | 0.75 | 1.7 | 197 | 179 | 8433 2212 19 |
| ETP ST32-10-10 | 3/8 | 3-11 | 2.2-8.0 | 1210 | 0.8 | 1.8 | 197 | 179 | 8433 2213 48 |
| ETP ST32-10-I06 | - | 3-11 | 2.2-8.0 | 1210 | 0.8 | 1.8 | 197 | 179 | 8433 2214 63 |
| ETP ST32-20-10 | 3/8 | 5-20 | 3.6-15.0 | 677 | 0.91 | 2 | 235 | 179 | 8433 2216 95 |
| ETP ST32-20-I06 | - | 5-20 | 3.6-15.0 | 677 | 0.91 | 2 | 235 | 179 | 8433 2217 11 |
| ETP ST32 with Barcode Scanner | | | | | | | | | |
| ETP ST32-05-I06BCR | - | 1-5 | 0.7-3.7 | 2820 | 0.87 | 2 | 197 | 205 | 8433 2212 29 |
| ETP ST32-10-I06BCR | - | 3-11 | 2.2-8.0 | 1210 | 0.92 | 2.1 | 197 | 205 | 8433 2214 73 |
| ETP ST32-20-I06BCR | - | 5-20 | 3.6-15.0 | 677 | 1.03 | 2.3 | 237 | 205 | 8433 2217 26 |

ST REVO

- Unique and patented 360° swivel with transducer.
- Ultra-compact size improves access.
- Reduced weight means less need for fixtures.
- Display on tool gives direct feedback of tightening result.
- Program selection is made directly on tool.
- Ideal for handheld application or fixtures with reduced space.
- Torque range from 60-4000 Nm.



ETP ST Rev0

| Model | Square drive in | Torque range | | Speed r/min | Weight | | Length mm | CS distance mm | Spline | Ordering No. |
|-----------------------|--------------------|--------------|----------|----------------|--------|------|--------------|-------------------|--------|--------------|
| | | Nm | ft lb | | kg | lb | | | | |
| Model with fan | | | | | | | | | | |
| ETP ST101-200-20-F | 3/4 | 60-200 | 45-145 | 396 | 5.2 | 11.5 | 303 | 32.5 | 3 | 8433 2302 02 |
| ETP ST101-300-20-F | 3/4 | 90-300 | 66-221 | 293 | 5.2 | 11.5 | 303 | 32.5 | 3 | 8433 2303 02 |
| ETP ST101-500-20-F | 3/4 | 150-500 | 110-365 | 186 | 5.9 | 13 | 334 | 33.5 | 4 | 8433 2305 02 |
| ETP ST101-750-25-F | 1 | 220-750 | 160-550 | 132 | 6.2 | 13.7 | 353 | 33.5 | 5 | 8433 2307 52 |
| ETP ST101-1000-25-F | 1 | 300-1000 | 220-735 | 99 | 6.4 | 14.1 | 364 | 33.5 | 5 | 8433 2310 02 |
| ETP ST101-1500-25-F | 1 | 450-1500 | 332-1106 | 47 | 8.8 | 19.4 | 402 | 43.5 | 9 | 8433 2321 52 |
| ETP ST101-2000-38-F | 1 1/2 | 600-2000 | 442-1475 | 38 | 11.5 | 25.4 | 454 | 48 | 7 | 8433 2322 02 |
| ETP ST101-3000-38-F | 1 1/2 | 900-3000 | 664-2212 | 24 | 14.8 | 33 | 476 | 59 | 8 | 8433 2323 02 |
| ETP ST101-4000-38-F | 1 1/2 | 1200-4000 | 885-2950 | 20 | 15 | 33 | 481 | 59 | 8 | 8433 2324 02 |

Reaction bar not included for ETP ST101. See accessory pages.

Tensor ST Crowfoot

IN-LINE CROWFOOT TOOLS

Dimensions

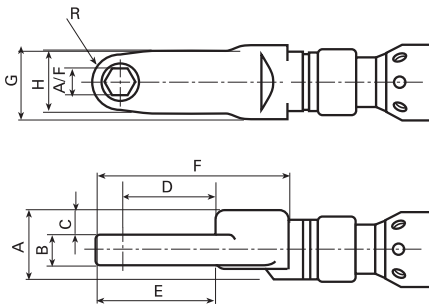

ETC ST

| Model | Torque range | | Speed r/min | Weight | | Length mm | A/F mm | A mm | B mm | C mm | D mm | E mm | F mm | G mm | H mm | R mm | Ordering No. |
|---------------------|--------------|--------|----------------|--------|-----|--------------|-----------|---------|---------|---------|---------|---------|---------|---------|---------|---------|--------------|
| | Nm | ft lb | | kg | lb | | | | | | | | | | | | |
| ETC ST61 | | | | | | | | | | | | | | | | | |
| ETC ST61-18-10-LI3 | 5-18 | 4-13 | 1429 | 1.9 | 4.2 | 523 | 10 | 34 | 15 | 12.5 | 36.7 | 59.2 | 82.2 | 35 | 22 | 10 | 8433 2311 11 |
| ETC ST61-28-12-LI3 | 6-28 | 4-20 | 767 | 1.9 | 4.2 | 526 | 12 | 34 | 15 | 12.5 | 45.5 | 71 | 94 | 35 | 30 | 13 | 8433 2311 14 |
| ETC ST61-90-21-LI3 | 20-90 | 14-66 | 316 | 4.1 | 9 | 684 | 21 | 46 | 20 | 16 | 74.5 | 44 | 158.8 | 64 | 40 | 20 | 8433 2311 44 |
| ETC ST61-120-18-LI3 | 30-136 | 22-100 | 217 | 4.3 | 9.5 | 684 | 18 | 46 | 32 | 11.5 | 74.8 | 146.5 | 157.8 | 64 | 38 | 19 | 8433 2311 38 |
| ETC ST61-100-19-LI3 | 26-110 | 19-81 | 250 | 4.2 | 9.2 | 678 | 19 | 46 | 28 | 13.5 | 69.6 | 74.9 | 151.6 | 64 | 36 | 18 | 8433 2311 35 |
| ETC ST61-150-22-LI3 | 33-150 | 24-110 | 197 | 4.4 | 9.7 | 688 | 22 | 48 | 33 | 14 | 77.5 | 84 | 161.5 | 64 | 40 | 20 | 8433 2311 47 |

OFFSET CROWFOOT TOOLS

Dimensions

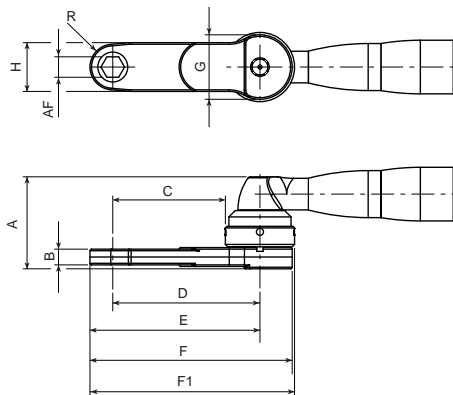

ETC ST

| Model | Torque range | | Speed r/min | Weight | | Length mm | A/F mm | A mm | B mm | C mm | D mm | E mm | F mm | G mm | H mm | R mm | F1 mm | Ordering No. |
|----------------------|--------------|--------|----------------|--------|------|--------------|-----------|---------|---------|---------|---------|---------|---------|---------|---------|---------|----------|--------------|
| | Nm | ft lb | | kg | lb | | | | | | | | | | | | | |
| ETC ST61 | | | | | | | | | | | | | | | | | | |
| ETC ST61-18-10-LO3 | 4-18 | 3-13 | 1450 | 1.5 | 3.3 | 469 | 10 | 60.3 | 15 | 14.55 | 32.8 | 42.8 | 57.8 | 36.5 | 22 | 10 | 61.1 | 8433 2310 09 |
| ETC ST61-28-12-LO5 | 5-28 | 4-20 | 1090 | 2 | 4.4 | 533 | 12 | 69.5 | 15 | 62 | 84 | 97 | 117.5 | 44 | 30 | 13 | 119 | 8433 2310 12 |
| ETC ST61-20-13-LO5 | 5-23 | 4-17 | 1090 | 1.7 | 3.7 | 534 | 13 | 57.5 | 10 | 71.6 | 93.6 | 108.1 | 128.6 | 44 | 31 | 14.5 | 130.1 | 8433 2310 15 |
| ETC ST61-44-14-LO3 | 8-44 | 6-32 | 655 | 2 | 4.4 | 497 | 14 | 69.5 | 18 | 24.8 | 46.8 | 61.3 | 81.8 | 44 | 31 | 14.5 | 83.3 | 8433 2310 18 |
| ETC ST61-64-16-LO3 | 12-64 | 9-47 | 475 | 2.5 | 5.5 | 512 | 16 | 77.8 | 24 | 27 | 51 | 66 | 88.5 | 48 | 30 | 15 | 90 | 8433 2310 27 |
| ETC ST61-80-17-LO3 | 16-80 | 12-59 | 350 | 3.1 | 6.8 | 534 | 17 | 81 | 27 | 31.8 | 55.8 | 72.3 | 94.8 | 48 | 33 | 16.5 | 96.3 | 8433 2310 30 |
| ETC ST61-90-21-LO5 | 24-90 | 17-66 | 227 | 4.2 | 9.2 | 664 | 21 | 89.4 | 20 | 100.8 | 132 | 152 | 178 | 62.5 | 40 | 20 | 183.3 | 8433 2310 45 |
| ETC ST61-100-19-LO5 | 21-110 | 15-81 | 227 | 4.4 | 9.7 | 653 | 19 | 96.9 | 28 | 91.2 | 122.4 | 140.4 | 166.4 | 62.5 | 36 | 18 | 171.7 | 8433 2310 36 |
| ETC ST61-140-18-LO3 | 28-140 | 20-103 | 190 | 4 | 8.8 | 595 | 18 | 96.9 | 32 | 32 | 63.2 | 82.2 | 108.2 | 62.5 | 38 | 19 | 113.5 | 8433 2310 39 |
| ETC ST61-150-21-LO3 | 32-150 | 23-110 | 185 | 4 | 8.8 | 596 | 21 | 99.7 | 33 | 34.8 | 66 | 86 | 112 | 62.5 | 40 | 20 | 117.3 | 8433 2310 48 |
| ETC ST101 | | | | | | | | | | | | | | | | | | |
| ETC ST101-200-21-LO3 | 52-215 | 38-158 | 380 | 9.3 | 20.5 | 731 | 21 | 148.8 | 40 | 32.75 | 70.4 | 91.4 | 125.4 | 75.3 | 42 | 21 | 128.2 | 8433 2310 51 |
| ETC ST101-200-22-LO3 | 52-200 | 38-147 | 380 | 9.3 | 20.5 | 738 | 22 | 139.8 | 37 | 38.55 | 76.2 | 98.7 | 132.7 | 75.3 | 45 | 22.5 | 135.5 | 8433 2310 57 |

IN-LINE TUBE NUT TOOLS

Dimensions

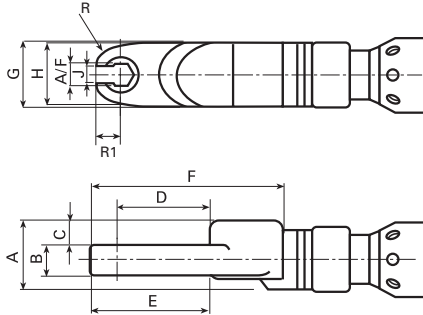

ETO ST

| Model | Torque range | | Speed r/min | Weight | | Length mm | A/F mm | A mm | B mm | C mm | D mm | E mm | F mm | G mm | H mm | J mm | R mm | R1 mm | Ordering No. |
|---------------------|--------------|-----------|----------------|--------|------|--------------|-----------|---------|---------|---------|---------|---------|---------|---------|---------|---------|---------|----------|--------------|
| | Nm | ft lb | | kg | lb | | | | | | | | | | | | | | |
| ETO ST61 | | | | | | | | | | | | | | | | | | | |
| ETO ST61-18-10-LI3 | 5-18 | 3.6-13 | 1278 | 1.8 | 4 | 522 | 10 | 34 | 11 | 14.5 | 34.1 | 31.1 | 81.5 | 35 | 38 | 8 | 11.9 | 15 | 8433 2311 68 |
| ETO ST61-20-10-LI3 | 5-20 | 3.7-14.7 | 1278 | 1.9 | 4.2 | 519 | 10 | 34 | 14 | 13 | 31.9 | 29.7 | 78.6 | 35 | 38 | 8 | 11.2 | 14 | 8433 2311 64 |
| ETO ST61-28-12-LI3 | 6-28 | 4.4-20.6 | 767 | 2.3 | 5.1 | 558 | 12 | 43 | 11 | 17.5 | 43.7 | 29.3 | 96.5 | 40 | 50 | 10.4 | 15 | 31 | 8433 2311 77 |
| ETO ST61-30-12-LI3 | 6-33 | 4.4-24.3 | 772 | 2.3 | 5.1 | 544 | 12 | 43 | 18 | 14 | 34.3 | 31.4 | 83 | 40 | 40 | 10.4 | 12.4 | 25 | 8433 2311 74 |
| ETO ST61-35-16-LI3 | 6-35 | 4.4-25.8 | 761 | 2.5 | 5.5 | 578 | 16 | 46 | 11 | 20.8 | 52 | 47.3 | 113.7 | 45 | 55 | 12.5 | 17.2 | 32 | 8433 2311 83 |
| ETO ST61-60-19-LI3 | 15-60 | 11-44 | 371 | 3.6 | 7.9 | 638 | 19 | 46 | 18 | 17 | 49.3 | 44.6 | 111 | 45 | 59 | 14 | 17.2 | 32 | 8433 2311 86 |
| ETO ST61-80-19-LI3 | 21-80 | 15-59 | 267 | 4.1 | 9 | 662 | 19 | 46 | 18 | 17 | 53.8 | 38.8 | 137.2 | 64 | 59 | 17 | 20.1 | 32 | 8433 2311 92 |
| ETO ST61-100-21-LI3 | 21-100 | 15.5-73.7 | 267 | 4.4 | 9.7 | 674 | 21 | 46 | 20 | 16 | 64.4 | 56.5 | 148.9 | 64 | 76 | 18 | 22.3 | 32 | 8433 2311 95 |
| ETO ST81 | | | | | | | | | | | | | | | | | | | |
| ETO ST81-100-24-LI3 | 39-110 | 28-81 | 240 | 4.6 | 10.1 | 706 | 24 | 46 | 20 | 16 | 71.3 | 50.6 | 160.4 | 64 | 77 | 20.5 | 24.6 | 33 | 8433 2311 98 |

OFFSET TUBE NUT TOOLS

Dimensions

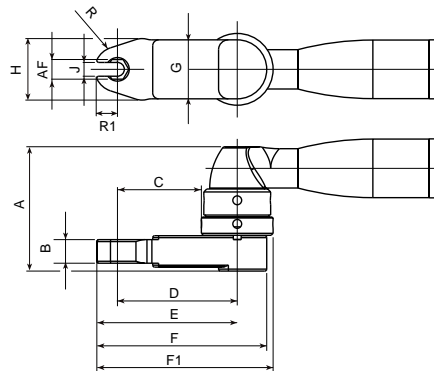

ETO ST

| Model | Torque range | | Speed r/min | Weight | | Length mm | A/F mm | A mm | B mm | C mm | D mm | E mm | F mm | G mm | H mm | J mm | R1 mm | R mm | F1 mm | Ordering No. |
|---------------------|--------------|----------|----------------|--------|-----|--------------|-----------|---------|---------|---------|---------|---------|---------|---------|---------|---------|----------|---------|----------|--------------|
| | Nm | ft lb | | kg | lb | | | | | | | | | | | | | | | |
| ETO ST61 | | | | | | | | | | | | | | | | | | | | |
| ETO ST61-18-12-LO3 | 5-18 | 3.7-13.2 | 1090 | 1.6 | 3.5 | 470 | 12 | 64 | 11 | 9.4 | 31.4 | 43.8 | 64.3 | 44 | 38 | 8.5 | 12.4 | 16 | 65.8 | 8433 2310 78 |
| ETO ST61-20-12-LO3 | 5-20 | 3.7-14.7 | 1450 | 1.6 | 3.5 | 466 | 12 | 64 | 14 | 7 | 29 | 40.2 | 60.7 | 44 | 38 | 8 | 11.2 | 14 | 62.2 | 8433 2310 72 |
| ETO ST61-28-13-LO3 | 6-28 | 4.4-20.6 | 1090 | 1.9 | 4.2 | 488 | 13 | 65 | 11 | 12.8 | 36.8 | 51.8 | 74.3 | 48 | 50 | 10.4 | 15 | 31 | 75.8 | 8433 2310 84 |
| ETO ST61-30-13-LO5 | 7-33 | 5.2-24.3 | 655 | 2.1 | 4.6 | 524 | 13 | 72.5 | 18 | 53.3 | 75.3 | 87.7 | 108.2 | 44 | 40 | 10.4 | 12.4 | 25 | 109.7 | 8433 2310 81 |
| ETO ST61-50-17-LO5 | 10-50 | 7.3-37 | 475 | 2.8 | 6.2 | 552 | 17 | 80 | 18 | 66.8 | 90.8 | 105.8 | 128.3 | 48 | 50 | 12 | 15 | 31 | 129.8 | 8433 2310 87 |
| ETO ST61-55-21-LO3 | 11-55 | 8.1-40.5 | 475 | 2.7 | 5.9 | 515 | 21 | 73.8 | 12 | 18 | 49.2 | 69.3 | 96.8 | 62.5 | 59 | 16 | 20.1 | 32 | 100.6 | 8433 2310 93 |
| ETO ST61-100-21-LO3 | 23-100 | 17-74 | 227 | 4.4 | 9.7 | 588 | 21 | 97.8 | 20 | 20.6 | 54.6 | 76.9 | 110.9 | 75.3 | 76 | 18 | 22.3 | 32 | 114.6 | 8433 2310 99 |
| ETO ST61-100-27-LO3 | 23-100 | 17-74 | 227 | 4.5 | 9.9 | 597 | 27 | 95.8 | 20 | 23.2 | 60 | 84.6 | 118.6 | 73.5 | 77 | 20.5 | 24.6 | 33 | 121.4 | 8433 2311 02 |

ETV STR

- Protected against intrusion of dust and water to withstand the toughest environments. IP class 54.
- Built in gyroscope to detect operators influence on tightening.
- Modular STR design for parts commonality between models and sizes.
- Dual accessories support for customizable functionality such as QR code scanning, EHMI display or headlights.
- High cycle rate capability due to improved heat dissipation.
- Operator feed back through built in loudspeaker, vibrator and high visibility LEDs.



ETV STR

| Model | Square drive in | Torque range | | Speed r/min | Weight | | Length mm | CS distance mm | Ordering No. |
|---|--------------------|--------------|----------|----------------|--------|-----|--------------|-------------------|--------------|
| | | Nm | ft lb | | kg | lb | | | |
| ETV STR31 | | | | | | | | | |
| ETV STR31-05-10 | 3/8 | 1-5 | 0.7-3.6 | 3070 | 1.1 | 2.4 | 381 | 11 | 8436 6130 05 |
| ETV STR31-10-10 | 3/8 | 3-12 | 2.2-8.8 | 1310 | 1.1 | 2.4 | 381 | 11 | 8436 6130 10 |
| ETV STR31-15-10 | 3/8 | 5-15 | 3.6-10 | 975 | 1.1 | 2.4 | 381 | 11 | 8436 6130 15 |
| ETV STR31-20-10 | 3/8 | 5-22 | 3.6-16 | 705 | 1.3 | 2.9 | 415 | 14 | 8436 6130 20 |
| ETV STR61 | | | | | | | | | |
| ETV STR61-25-10 | 3/8 | 6-28 | 4-20 | 1620 | 1.4 | 3.1 | 439 | 14 | 8436 6160 25 |
| ETV STR61-30-10 | 3/8 | 7-35 | 5-25 | 1220 | 1.4 | 3.1 | 441 | 15.5 | 8436 6160 30 |
| ETV STR61-40-10 | 3/8 | 8-40 | 6-29 | 1220 | 1.6 | 3.5 | 452 | 18 | 8436 6160 40 |
| ETV STR61-50-10 | 3/8 | 10-55 | 7-40 | 735 | 1.6 | 3.5 | 452 | 18 | 8436 6160 50 |
| ETV STR61-70-13 | 1/2 | 15-80 | 10-58 | 530 | 2.1 | 4.6 | 464 | 20 | 8436 6160 70 |
| ETV STR61-100-13 | 1/2 | 20-100 | 15-80 | 390 | 2.6 | 5.7 | 501 | 22.5 | 8436 6160 10 |
| ETV STR61-150-13 | 1/2 | 30-160 | 22-117 | 245 | 3.0 | 6.6 | 537 | 25.5 | 8436 6160 15 |
| ETV STR61-180-13 | 1/2 | 35-180 | 26-133 | 215 | 3.0 | 6.6 | 543 | 25.5 | 8436 6160 18 |
| ETV STR61-200-20 | 3/4 | 40-200 | 30-154 | 215 | 3.1 | 6.8 | 539 | 27 | 8436 6160 20 |
| ETV STR61 Ball Retainer | | | | | | | | | |
| ETV STR61-70-B13 | 1/2 | 15 - 80 | 10 - 58 | 530 | 2.1 | 4.6 | 464 | 20 | 8436 0000 20 |
| ETV STR61-100-B13 | 1/2 | 20 - 100 | 15 - 80 | 350 | 2.6 | 5.7 | 501 | 22.5 | 8436 0000 25 |
| ETV STR61-150-B13 | 1/2 | 30 - 160 | 22 - 117 | 245 | 3.0 | 6.6 | 537 | 25.5 | 8436 0000 40 |
| ETV STR61-180-B13 | 1/2 | 35 - 180 | 26 - 133 | 215 | 3.0 | 6.6 | 543 | 25.5 | 8436 0000 30 |
| ETV STR61 Barcode scanner and Lamp | | | | | | | | | |
| ETV STR61-30-10-BL | 3/8 | 7-35 | 5-25 | 1220 | 1.5 | 3.3 | 441 | 15.5 | 8436 6169 31 |
| ETV STR61-40-10-BL | 3/8 | 8-40 | 6-29 | 1220 | 1.7 | 3.7 | 452 | 18 | 8436 6169 41 |
| ETV STR61-50-10-BL | 3/8 | 10-55 | 7-40 | 735 | 1.7 | 3.7 | 452 | 18 | 8436 6169 51 |
| ETV STR61-70-13-BL | 1/2 | 15-80 | 10-58 | 530 | 2.2 | 4.8 | 464 | 20 | 8436 6169 71 |
| ETV STR61 Flush Socket | | | | | | | | | |
| ETV STR61-30-FS | | 7 - 35 | 5 - 25 | 1220 | 1.4 | 3.1 | 441 | 16 | 8436 6161 43 |
| ETV STR61-40-FS | | 8 - 40 | 6 - 29 | 1220 | 1.6 | 3.5 | 452 | 18 | 8436 6161 50 |
| ETV STR61-50-FS | | 10 - 55 | 7 - 40 | 735 | 1.6 | 3.5 | 452 | 18 | 8436 6161 57 |
| ETV STR61-70-FS | | 15 - 80 | 10 - 58 | 530 | 2.1 | 4.6 | 464 | 20 | 8436 6161 64 |
| ETV STR61-100-FS | | 20 - 110 | 15 - 80 | 390 | 2.6 | 5.7 | 501 | 23 | 8436 6161 08 |
| ETV STR61-150-FS | | 30 - 160 | 22 - 117 | 237 | 3 | 6.6 | 540 | 26 | 8436 6161 15 |
| ETV STR61-180-FS | | 35 - 180 | 26 - 133 | 190 | 3.0 | 6.6 | 546 | 26 | 8436 6161 22 |
| ETV STR61-200-FS | | 40 - 200 | 30 - 154 | 215 | 3.1 | 6.8 | 543 | 27 | 8436 6161 29 |
| ETV STR61 Hold And Drive | | | | | | | | | |
| ETV STR61-30-HAD | | 7 - 35 | 5 - 25 | 1220 | 2 | 4.4 | 464 | 18.3 | 8436 6161 42 |
| ETV STR61-50-HAD | | 10 - 50 | 7 - 40 | 735 | 2.1 | 4.6 | 438 | 18.3 | 8436 6161 56 |
| ETV STR61-100-HAD | | 20 - 100 | 15 - 80 | 390 | 2.7 | 5.9 | 503 | 23 | 8436 6161 07 |
| ETV STR61-150-HAD | | 30 - 160 | 22 - 117 | 237 | 3.1 | 6.6 | 541 | 26 | 8436 6161 14 |
| ETV STR61-180-HAD | | 35 - 180 | 26 - 133 | 215 | 3.1 | 6.6 | 539 | 26 | 8436 6161 21 |
| ETV STR61-200-HAD | | 40 - 200 | 30 - 154 | 215 | 3.2 | 7.0 | 543 | 26 | 8436 6161 28 |

ETD STR

- Protected against intrusion of dust and water to withstand the toughest environments. IP class 54.
- Built in gyroscope to detect operators influence on tightening.
- Modular STR design for parts commonality between models and sizes.
- Dual accessories support for customizable functionality such as QR code scanning, EHMI display or headlights.
- High cycle rate capability due to improved heat dissipation.
- Operator feed back through built in loudspeaker, vibrator and high visibility LEDs.



ETD STR

| Model | Square drive in | Torque range | | Speed r/min | Weight | | Length mm | CS distance mm | Ordering No. |
|------------------|--------------------|--------------|---------|----------------|--------|-----|--------------|-------------------|--------------|
| | | Nm | ft lb | | kg | lb | | | |
| ETD STR31 | | | | | | | | | |
| ETD STR31-05-10 | 3/8 | 1-5 | 0.7-3.6 | 3645 | 1.0 | 2.2 | 388 | 24 | 8436 6230 05 |
| ETD STR31-10-10 | 3/8 | 2-10 | 1.4-7.3 | 1555 | 1.2 | 2.6 | 388 | 24 | 8436 6230 10 |
| ETD STR61 | | | | | | | | | |
| ETD STR61-15-10 | 3/8 | 4-16 | 3-12 | 2500 | 1.4 | 3.1 | 438 | 24 | 8436 6260 15 |
| ETD STR61-20-10 | 3/8 | 5-22 | 3.6-16 | 1890 | 1.4 | 3.1 | 438 | 24 | 8436 6260 20 |
| ETD STR61-30-10 | 3/8 | 6-35 | 4.4-25 | 1130 | 1.4 | 3.1 | 429 | 24 | 8436 6260 30 |
| ETD STR61-50-13 | 1/2 | 10-55 | 7.3-40 | 819 | 2.0 | 4.4 | 474 | 24 | 8436 6260 50 |
| ETD STR61-70-13 | 1/2 | 15-80 | 12-58 | 560 | 2.3 | 5.1 | 491 | 26.5 | 8436 6260 70 |
| ETD STR61-90-13 | 1/2 | 20-95 | 15-70 | 440 | 2.3 | 5.1 | 491 | 26.5 | 8436 6260 90 |

Pistol Grip Models

Tensor STR

ETP STR

- Available in two models, standard and cable on top.
- Outstanding power to weight ratio, increase by 45% compared to Tensor S
- New D-handle shape for increased robustness and safety.
- Easy mounting of additional accessories or optional support handle.
- High cycle rate capability due to improved heat dissipation.
- Operator feed back through built in loudspeaker, vibrator and high visibility LEDs.



ETP STR

| Model | Square drive in | Torque range | | Speed r/min | Weight | | Length mm | CS distance mm | Ordering No. |
|-------------------------------|--------------------|--------------|-----------|----------------|--------|------|--------------|-------------------|--------------|
| | | Nm | ft lb | | kg | lb | | | |
| ETP STR61 | | | | | | | | | |
| ETP STR61-20-10 | 3/8 | 5-22 | 3.7-16.2 | 2100 | 1.3 | 2.87 | 244 | 24 | 8436 6360 20 |
| ETP STR61-30-10 | 3/8 | 6-32 | 4.4-23.5 | 1530 | 1.3 | 2.87 | 244 | 24 | 8436 6360 30 |
| ETP STR61-50-13 | 1/2 | 10-55 | 7.4-40.6 | 820 | 1.7 | 3.75 | 282 | 24 | 8436 6360 50 |
| ETP STR61-70-13 | 1/2 | 14-80 | 10.3-59 | 560 | 2.0 | 4.41 | 298 | 26.5 | 8436 6360 70 |
| ETP STR61-90-13 | 1/2 | 20-95 | 14.7-70.4 | 450 | 2.0 | 4.41 | 298 | 26.5 | 8436 6360 90 |
| ETP STR61-120-13 | 1/2 | 24-125 | 17.7-89.4 | 380 | 2.0 | 4.41 | 298 | 26.5 | 8436 6360 12 |
| ETP STR61 Cable On Top | | | | | | | | | |
| ETP STR61-120-13 COT | 1/2 | 24-125 | 17.7-89.4 | 380 | 2.4 | 5.29 | 350 | 26.5 | 8436 6368 12 |
| ETP STR61-20-10 COT | 3/8 | 5-22 | 3.7-16.2 | 2100 | 1.7 | 3.75 | 296 | 24 | 8436 6368 20 |
| ETP STR61-30-10 COT | 3/8 | 6-32 | 4.4-23.5 | 1530 | 1.7 | 3.75 | 296 | 24 | 8436 6368 30 |
| ETP STR61-50-13 COT | 1/2 | 10-55 | 7.4-40.6 | 820 | 2.1 | 4.63 | 334 | 24 | 8436 6368 50 |
| ETP STR61-70-13 COT | 1/2 | 14-80 | 10.3-59 | 560 | 2.4 | 5.29 | 350 | 26.5 | 8436 6368 70 |
| ETP STR61-90-13 COT | 1/2 | 20-95 | 14.7-70.4 | 450 | 2.4 | 5.29 | 350 | 26.5 | 8436 6368 90 |

ETT STR

- Transducer in front for outstanding accuracy and reliability. +/- 2,5% over 6 sigma.
- Built in gyroscope to detect operators influence on tightening.
- Modular STR design for parts commonality between models and sizes.
- Additional front trigger makes the tool ideal for a combined pre tightening and final tightening combination, two tools in one. front trigger can also be used a safety trigger
- High cycle rate capability due to improved heat dissipation.
- Operator feed back through built in loudspeaker, vibrator and high visibility LEDs.



ETT STR

| Model | Square drive in | Torque range | | Speed r/min | Weight | | Length mm | CS distance mm | Ordering No. |
|------------------|--------------------|--------------|-------|----------------|--------|-----|--------------|-------------------|--------------|
| | | Nm | ft lb | | kg | lb | | | |
| ETT STR61 | | | | | | | | | |
| ETT STR61-20-10 | 3/8 | 4-20 | 3-15 | 1690 | 1.6 | 3.6 | 384 | 24 | 8436 6660 20 |
| ETT STR61-30-10 | 3/8 | 6-30 | 4-22 | 1300 | 1.6 | 3.6 | 384 | 24 | 8436 6660 30 |
| ETT STR61-40-10 | 3/8 | 8-40 | 6-30 | 1015 | 1.7 | 3.7 | 384 | 24 | 8436 6660 40 |
| ETT STR61-50-10 | 3/8 | 10-50 | 7-37 | 780 | 1.7 | 3.7 | 384 | 24 | 8436 6660 50 |

Tensor SR

ETV SR

- SR Angle tools are extremely fast, compact and easy to operate.
- ESD certified.
- Easy to configure the function button.
- Front LED's gives better operator feedback.
- Torque range from 2.5 to 30 Nm.



ETV SR

ETD SR

- SR Straight tools are ideal for hand-held applications and fixture applications.
- Torque range from 1.5 to 16 Nm.
- Front light guide is integrated.
- Push-to-start mechanism.
- ESD certified.



ETD SR

| Model | Torque range | | Speed r/min | Weight | | Length mm | CS distance mm | Spline/ Mounting | Ordering No. |
|------------------------|--------------|----------|----------------|--------|-----|--------------|-------------------|---------------------|--------------|
| | Nm | ft lb | | kg | lb | | | | |
| Angle models | | | | | | | | | |
| ETV SR21-12-10 | 2.5-12 | 1.9-8.9 | 1350 | 1.1 | 2.4 | 297 | 14 | - | 8436 4120 12 |
| ETV SR21-25-10 | 5-25 | 3.7-18.5 | 1000 | 1.2 | 2.6 | 297 | 14 | - | 8436 4120 25 |
| ETV SR21-30-10 | 6-30 | 4.4-22.1 | 663 | 1.2 | 2.6 | 299 | 15.5 | - | 8436 4120 30 |
| Straight models | | | | | | | | | |
| ETD SR21-07-I06-PS | 1.5-7 | 1.0-5.2 | 2090 | 0.9 | 1.9 | 259 | 24 | - | 8436 4220 07 |
| ETD SR21-16-I06-PS | 3.5-16 | 2.6-11.8 | 1460 | 1.0 | 2.2 | 276 | 24 | - | 8436 4220 16 |
| ETD SR21-07-I06-T25 | 1.5-7 | 1.0-5.2 | 2090 | 0.9 | 1.9 | 353 | 24 | - | 8436 4224 07 |
| ETD SR21-16-10-T25 | 3.5-16 | 2.6-11.8 | 1460 | 1.0 | 2.2 | 353 | 24 | - | 8436 4224 17 |

Optional Accessories

TENSOR ST/SR/STR

| Model | Power Focus 4000 Ordering No. | Power Focus 6000 Ordering No. |
|--|----------------------------------|----------------------------------|
| Tool cable | | |
| 2 m | 4220 2636 02 | 4220 4375 02 |
| 3 m | 4220 2636 03 | 4220 4375 03 |
| 5 m | 4220 2636 05 | 4220 4375 05 |
| 7 m | 4220 2636 07 | 4220 4375 07 |
| 10 m | 4220 2636 10 | 4220 4375 10 |
| 15 m | 4220 2636 15 | 4220 4375 15 |
| Cables with 90 degrees connector | | |
| 2 m | 4220 3891 02 | |
| 3 m | 4220 3891 03 | |
| 5 m | 4220 3891 05 | |
| 7 m | 4220 3891 07 | |
| 10 m | 4220 3891 10 | |
| 15 m | 4220 3891 15 | |
| Spiral cable (length/stretched length) | | |
| 3 m / 4 m | 4220 2757 03 | |
| 7 m / 8 m | 4220 2757 07 | |
| 10 m / 12 m | 4220 2757 10 | |
| Cable protection 2 m | | |
| | 4220 2977 90 | |
| Extension cable (round, heavy duty) | | |
| 3 m | | 4220 4393 03 |
| 5 m | 4220 1007 05 | 4220 4393 05 |
| 10 m | 4220 1007 10 | 4220 4393 10 |
| 15 m | 4220 1007 15 | 4220 4393 15 |
| Extension cables for fixtured applications (flat) | | |
| 5 m | 4220 1563 05 | |
| 10 m | 4220 1563 10 | |
| 15 m | 4220 1563 15 | |



ST/SR/STR Cable



ST/SR/STR Cable with 90 degrees connector



ST/SR/STR Spiral cable



ST/SR/STR Cable protection



DS Tool cable

TENSOR ES

| Model | Ordering No. |
|--|--------------|
| Round cables for ES21 | |
| 2 m | 4220 4204 02 |
| 3 m | 4220 4204 03 |
| 5 m | 4220 4204 05 |
| 7 m | 4220 4204 07 |
| 10 m | 4220 4204 10 |
| 15 m | 4220 4204 15 |
| Flat cables for ES61 | |
| 3 m | 4220 4339 03 |
| 5 m | 4220 4339 05 |
| 7 m | 4220 4339 07 |
| 10 m | 4220 4339 10 |
| 15 m | 4220 4339 15 |
| Extension cables for all cables | |
| 3 m | 4220 4393 03 |
| 5 m | 4220 4393 05 |
| 10 m | 4220 4393 10 |
| 15 m | 4220 4393 15 |
| Suspension yoke cable for ES21 | |
| Suspension yoke cable | 4210 1810 00 |

TENSOR DS

| Model | Ordering No. |
|------------------------|--------------|
| Tool cable | |
| 2 m | 4220 4380 02 |
| 3 m | 4220 4380 03 |
| 5 m | 4220 4380 05 |
| 7 m | 4220 4380 07 |
| 10 m | 4220 4380 10 |
| 15 m | 4220 4380 15 |
| Extension cable | |
| 5 m | 4220 2047 05 |
| 10 m | 4220 2047 10 |
| 15 m | 4220 2047 15 |

Optional Accessories

TOOL EXTENSIONS

| Model | Length | Ordering No. |
|---|--------|--------------|
| ES61 ETV 70/100/150/180/200, ES61 ETD 50/70/90/120 | 150 | 4220 1132 80 |
| ES61 ETV 25/30/40/50, ES61 ETD 18/25/30 | 150 | 4220 1131 80 |
| DS7 ETD 20-30, DS7 ETV 30-50, DS4 ETD/ETV | 150 | 4220 1131 80 |
| DS4 ETD/ETV | 100 | 4220 1131 86 |
| DS7 ETD/ETV 50-200 | 150 | 4220 1714 80 |
| DS9 ETD/ETV 270-370 | 150 | 4220 1585 80 |
| DS9 ETD 450-600 | 150 | 4220 1585 85 |
| ST61 ETV 20-30 | 150 | 4220 2903 96 |
| ST61 ETV 40-50 | 150 | 4220 2903 95 |
| ST61 ETV 70 | 150 | 4220 2903 97 |
| ST61/ST81/ST101 ETV 100-200 | 150 | 4220 2903 91 |
| ST101 270-1000 | 150 | 4220 1585 80 |
| ST101 600 | 150 | 4220 1585 85 |
| STR61 ETV 25 | 150 | 4220 2903 80 |
| STR61 ETV 30 | 150 | 4220 2903 96 |
| STR61 ETV 40-50 | 150 | 4220 2903 95 |
| STR61 ETV 70 | 150 | 4220 2903 97 |
| STR61 ETV 100-200 | 150 | 4220 2903 91 |



Tool extension



SUPPORTED EXTENSIONS (~154 MM)

| Tensor ST/SR | Tensor STR | Tensor DS | Tensor ES | Ordering No. |
|-------------------------------|----------------------------|-------------------|----------------|--------------|
| SR21, ST31 ETV 20, ST61 28-30 | STR61 ETV 30 | | ES61 ETV 25/30 | 4220 3869 90 |
| ST61/ST81 ETV 40-50 | STR31 ETV 20, STR61 ETV 25 | DS2/DS7 ETV 20-30 | | 4220 3868 90 |
| ST61/ST81 ETV 70 | STR61 ETV 40-50 | DS7/DS9 ETV 40-50 | ES61 ETV 40/50 | 4220 2209 91 |
| ST61/81/101 ETV 150-180 | STR61 ETV 70 | DS7/DS9 ETV 70 | ES61 ETV 70 | 4220 2596 91 |
| ST61 ETV 200 | STR61 ETV 150-180 | | | 4220 4125 90 |
| ST81/101 ETV 200 | STR61 ETV 200 | | | 4220 4125 92 |
| | | | ES61 ETV 100 | 4220 4125 91 |



COVERS FOR STANDARD SOCKETS

| Tensor DS | Tensor ES | Tensor ST | Tensor SR | Tensor STR | Ordering No |
|---------------------|-----------------------|----------------------|-----------|-------------------|--------------|
| | | ST31 ETV 20 | SR21 | STR31 ETV 20 | 4220 3154 03 |
| | ES61 ETD 18/ 25/ 30 | | | | 4220 3251 02 |
| | ES61 ETD 50/70/90/120 | | | | 4220 3251 03 |
| | ES61 ETV 25 | ST61 ETV 28 | | STR61 ETV 25 | 4220 3154 03 |
| | ES61 ETV 30 | ST61 ETV 30 | | STR61 ETV 30 | 4220 3154 04 |
| | ES61 ETV 100 | ST ETV 100 | | STR61 ETV 100 | 4220 3154 05 |
| | ES61 ETV 150/180 | ST ETV 150-180 | | STR61 ETV 150-180 | 4220 3154 06 |
| | ES61 ETV 40/50 | ST ETV 40-50 | | STR61 ETV 40-50 | 4220 1995 05 |
| | ES61 ETV 70 | ST ETV 70 | | STR61 ETV 70 | 4220 1993 03 |
| DS7 200 | ES61 ETV 200 | ST ETV 61/81/101 200 | | STR61 ETV 200 | 4220 3154 07 |
| DS9 ETV 101 270-370 | | ST101 ETV 270-370 | | | 4220 3154 08 |
| DS7 ETD 50-120 | | ST61/81 ETD 50-120 | | | 4220 3251 00 |
| DS7 ETD 20/30/120 | | ST61 ETD 15/20/30 | | | 4220 3251 02 |

Optional Accessories

REACTION PLATE FOR FIXTURING

| Model | Ordering No. |
|------------------------------|--------------|
| ES61 ETV-40/50 | 4220 1677 92 |
| ES61 ETV-70/100 | 4220 1678 94 |
| ES61 ETV-150/180 | 4220 1677 98 |
| ES61 ETV-200 | Included |
| ST10 ETV 180 | 4220 1677 99 |
| ST10 ETV 200-600 | Included |
| ST61 ETV 30, ST61/81 ETV 200 | 4220 1677 91 |
| ST61 ETV 40-50 | 4220 1677 93 |
| ST61/81 ETV 70 | 4220 1677 95 |
| ST61/81 ETV 100 | 4220 1677 97 |
| ST61/81 ETV 150-180 | 4220 1678 90 |
| ST32 ETP 20 106BCR | 4220 3491 00 |
| STR31 ETV 5-20 | 4220 1678 91 |
| STR61 ETV 30 | 4220 1677 91 |
| STR61 ETV 40-50 | 4220 1677 93 |
| STR61 ETV 70 | 4220 1677 95 |
| STR61 ETV 100 | 4220 1677 97 |
| STR61 ETV 150-180 | 4220 1678 90 |



Reaction plate

LEVER TENSOR DS / ST / SR

| Model | Ordering No. |
|---------------------|--------------|
| Lever, DS | 4220 1642 80 |
| Lever, ST | 4220 3511 81 |
| Spoon lever, SR21 | 4220 4338 83 |
| Extended lever, DS | 4220 1642 85 |
| Extended lever, ST | 4220 3511 85 |
| Lock-off lever, DS | 4220 2356 80 |
| Lock-off lever, STR | 4220 5221 85 |
| Lock-off lever, ST | 4220 3511 83 |



Lock-off lever

REACTION BARS AND MOUNTING BRACKETS

| Number | Spline type | Type | L / W / H | Ordering No. |
|-------------------------|---------------|------------|------------|--------------|
| 1 | - | Bracket | 100/60/8 | 4220 1029 00 |
| 2 | Spline type 2 | Bracket | 70/41/14 | 4210 2134 02 |
| 3 | | Triangular | 73/72/14 | 4220 2137 02 |
| 4 | | Bar | 270/35/14 | 4220 1903 00 |
| 5 | Spline type 3 | Bracket | 100/50/12 | 4210 2219 03 |
| 6 | | Triangular | 82/80/12 | 4220 2137 03 |
| 7 | | Bar | 400/29/12 | 4210 2219 80 |
| 8 | Spline type 6 | Bracket | 200/100/15 | 4220 1200 00 |
| 9 | | Triangular | 112/109/15 | 4220 2137 06 |
| 10 | | Bar | 560/80/15 | 4220 1200 01 |
| 11 | Spline type 7 | Bracket | 250/150/20 | 4220 1445 00 |
| 12 | Spline type 8 | Bracket | 250/160/20 | 4220 1972 00 |
| 13 | - | Bracket | 100/60/8 | 4220 1029 01 |
| 14 | - | Bracket | 100/60/8 | 4220 1029 02 |
| For model | | | | |
| ST10 ETD 120 | | Bracket | 150/100/16 | 4220 3677 00 |
| ST10 ETD 200/300/500 | | Bracket | 200/150/16 | 4220 3677 01 |
| ST10 ETD 750/1000 | | Bracket | 200/150/20 | 4220 3677 02 |
| STR61 ETP 20/30 | | Bar | 250/15/8 | 4220 4495 00 |
| STR61 ETP 50/70/90/120, | | Bar | 270/35/14 | 4220 1903 00 |
| ES61 ETD 18/25/30 | | | | |
| ES61 ETD 50/70/90/120 | | Bar | | 4210 2219 80 |

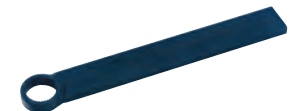

Reaction bar



Mounting bracket



Triangular

Mounting bracket is included for some tool models.
Please match the number from the table with the tool tables.

Optional Accessories

SUSPENSION YOKES

| Model | Type | Assembly | Ordering No. |
|---------------------------------------|-------------------|-----------------|--------------|
| ES21 ETV/ETD | Horizontal | Motor | 4220 0987 82 |
| ES61 ETV/ETD | Horizontal | Motor | 4220 4586 90 |
| DS4/DS7/DS9 ETD/ETV | Vertical | Handle | 4220 1417 80 |
| DS4/DS7 ETD/ETV | Horizontal | Motor | 4220 0987 85 |
| DS4/DS7 ETP | Horizontal | Motor | 4220 1154 90 |
| DS4 ETD/ETV | Fixed | Motor front nut | 4220 1675 86 |
| DS9 ETD/ETV | Horizontal | Motor | 4220 1418 96 |
| DS9 ETP 350/500 | Swivelling | | 4210 3088 86 |
| DS9 ETP 750 | Swivelling | | 4210 3088 83 |
| DS9 ETP 1500 | Swivelling | | 4210 3088 81 |
| ST10 ETD 120-300, ST10 ETV 270-600 | Vertical | Planetary gear | 4220 1418 91 |
| ST10 ETD 500-1000 | Vertical | Planetary gear | 4220 1418 90 |
| ST10 ETV 100-200 | Vertical | Planetary gear | 4220 1418 92 |
| ST31/61 ETV/ETD | Horizontal | Motor | 4220 2657 90 |
| ST31/61 ETV/ETD | Fixed | Motor | 4220 2843 92 |
| ST31/61 ETV/ETD | Vertical | Handle | 4220 1417 95 |
| ST81 ETV/ETD | Horizontal | Motor | 4220 0987 90 |
| ST81 ETV/ETD | Fixed | Motor | 4220 2843 91 |
| ST101 ^a ETV | Horizontal | Motor | 4220 3930 90 |
| ST101 ETD 200-1000 | Adjustable | Motor | 4220 4075 90 |
| ST101 ETP BCR 200-1000 ^b | Adjustable | Motor | 4220 4075 91 |
| ST101 ETP 750-2000 | Swivelling | Gear | 4210 3088 87 |
| ST101 ETP 3000-4000 | Swivelling | Gear | 4210 3088 81 |
| STR ETV/ETD 31/61 | Swivelling | | 4220 5070 80 |
| STR ETV/ETD 31/61 | Fixed | | 4220 5105 80 |
| STR61 ETP | Tool upside down | | 4220 3037 00 |
| STR61 ETP | Fixed, one side | | 4220 4334 00 |
| STR61 ETP | Fixed, both sides | | 4220 4399 80 |
| STR61 ETP 20/30/50 | Swivelling | | 4220 4381 80 |
| STR61 ETP 70/90/120 | Swivelling | | 4220 4394 80 |
| SR21 | For rear | | 4220 4410 80 |
| SR21 | For front | | 4220 4409 80 |

^a Not telescopic. ^b To be used if barcode scanner is mounted.



Suspension yokes

DUAL TRIGGER FOR OPEN END

| Model | ETV | ETD | Ordering No. |
|---------|--------------------------|--------------------------|--------------|
| ST61-S | ST31, ST61 05-50 | ST31, ST61 15-30 | 4220 3186 90 |
| ST61-L | ST61 70-200 | ST61 50-120 | 4220 3186 91 |
| ST81-S | ST81 50 | ST81 30 | 4220 3186 92 |
| ST81-L | ST81 70-180 | ST81 50-120 | 4220 3186 93 |
| ST101 | ST10 100-1000 | ST10 100-1000 | 4220 3186 96 |
| STR - L | STR61 70-200 | STR61 70 | 8436 6199 12 |
| STR - S | STR31 05-20, STR61 25-50 | STR31 05-10, STR61 15-50 | 8436 6199 10 |



Lever trigger top

DUAL TRIGGER FOR OPEN END 135 DEG.

| Model | ETV | ETD | Ordering No. |
|---------|------------------|------------------|--------------|
| ST61-S | ST31, ST61 28-50 | ST31, ST61 15-30 | 4220 3311 90 |
| ST61-L | ST61 70-200 | ST61 50-120 | 4220 3311 91 |
| ST81-S | ST81 50 | ST81 30 | 4220 3311 92 |
| ST81-L | ST81 70-200 | ST81 50-120 | 4220 3311 93 |
| ST101 | ST10 100-1000 | ST10 100-1000 | 4220 3311 94 |
| STR - L | | | 8436 6199 22 |
| STR - S | | | 8436 6199 20 |



Lever trigger 135 deg.

Optional Accessories

FIXTURED EXTENSIONS

| Model | For ext + nut Ordering No. | For nut only Ordering No. |
|--|-------------------------------|------------------------------|
| ES61 ETV 25/30/40/50, ES61 ETD 18/25/30 | | 4220 2579 90 |
| ES61 ETV 70/100/150/180/200, ES61 ETD 50/70/90/120 | | 4220 2469 90 |
| ST10 ETV 100/150/180, ST10 ETD 120 | 4220 3571 90 | Included |
| ST10 ETD 150, 200, 300 | 4220 3572 90 | |
| ST10 ETD 500 | 4220 3573 90 | Included |



Fixture extension

PROTECTIVE COVERS

| Model | Ordering No. |
|-----------------------------------|--------------|
| ST31 ETV 5-15 | 4220 2744 05 |
| ST31/ST61 ETV 20-30, ST31 ETV 200 | 4220 2744 03 |
| ST61 ETV 40-50, ST81 ETV 50 | 4220 2744 02 |
| ST61 ETV 70, ST81 ETV 70 | 4220 2744 04 |
| ST31 ETP 05 | 4220 2744 06 |
| ST31 ETP 10 | 4220 2744 07 |
| ST81/ST10 ETV 150-180 | 4220 2744 10 |
| ST81/ST10 ETV 100 | 4220 2744 09 |
| ST101 ETP (included) | 4220 4299 00 |
| STR31 ETV 05-15 | 4220 5203 01 |
| STR31 ETV 20, STR61 ETV 20-30 | 4220 5203 02 |
| STR61 ETV 40-50 | 4220 5203 03 |
| STR61 ETV 70 | 4220 5203 04 |
| STR61 ETV 100 | 4220 5203 05 |
| STR61 ETV 150-180 | 4220 5203 06 |



Protective cover Tensor ST

OPERATOR HANDLE

| Model | Ordering No. |
|-----------|--------------|
| STR61 ETP | 4220 4487 80 |
| ST101 ETP | 4220 4522 82 |



Operator handle

SUPPORT HANDLE

| Model | Ordering No. |
|-------------------------------|--------------|
| ES21 ETV/ETD | 4220 2725 83 |
| DS9 ETP 350/500/750/1500 | 4220 4374 90 |
| SR21 ETD | 4220 4347 80 |
| ST31/32 ETP 5-10 | 4220 3517 80 |
| ST101 ETP 200/500 (included) | 4220 4001 84 |
| ST101 ETP 750/1000 (included) | 4220 4001 83 |
| STR61 ETP | 4220 4343 80 |



Support handle

TORQUE MULTIPLIER (REACTION BAR INCLUDED)

| Model | Max. torque Nm | Gear ratio | Square in | Square out | Ordering No. |
|-------------|-------------------|---------------|--------------|---------------|--------------|
| T-Mult 120 | 30 | 4.54 | 3/8 | 1/2 | 8431 0453 53 |
| T-Mult 200 | 50 | 4.62 | 3/8 | 3/4 | 8433 0310 07 |
| T-Mult 400 | 100 | 4.10 | 1/2 | 3/4 | 8431 0493 65 |
| T-Mult 500 | 30 | 16.11 | 3/8 | 3/4 | 8433 0310 28 |
| T-Mult 800 | 45 | 18.50 | 1/2 | 1 | 8433 0311 81 |
| T-Mult 1000 | 250 | 4.00 | 3/4 | 1 | 8433 0312 16 |
| T-Mult 1500 | 72 | 21.10 | 1/2 | 1 | 8433 0312 20 |

TOOL HOLDER

| Model | Ordering No. |
|----------|--------------|
| ST32 ETP | 4220 3584 80 |



Tool holder

Optional Accessories



CAUTION: This device emits CDRH/IEC Class 2 laser radiation. Do not stare into beam.

BARCODE SCANNER

| Model | ETV | ETD | Ordering No. |
|-----------|------------------|------------------|--------------|
| ST61-S | ST31, ST61 28-50 | ST31, ST61 15-30 | 8433 0615 10 |
| ST61-L | ST61 70-200 | ST61 50-120 | 8433 0615 20 |
| ST81-S | ST81 50 | ST81 30 | 8433 0615 30 |
| ST81-L | ST81 70-200 | ST81 50-120 | 8433 0615 40 |
| STR61 ETP | | | 8436 0999 90 |
| ST101 ETP | | | 8433 0615 50 |
| STR-S | STR 31 /61 | STR 31 /61 | 8436 6199 00 |
| STR-L | STR61 | STR61 | 8436 6199 02 |

L= 70 Nm and up, S= up to 50 Nm



Barcode scanner

PARAMETER SET SELECTOR

| Model | ETV | ETD | Ordering No. |
|-----------|------------------|------------------|--------------|
| ST61-S | ST31, ST61 28-50 | ST31, ST61 15-30 | 8433 0616 05 |
| ST61-L | ST61 70-200 | ST61 50-120 | 8433 0616 15 |
| ST81-S | ST81 50 | ST81 30 | 8433 0616 25 |
| ST81-L | ST81 70-200 | ST81 50-120 | 8433 0616 35 |
| ST101 | ST10 | ST10 | 8433 0616 45 |
| STR61 ETP | | | 8436 0999 91 |



Parameter set selector

TLS TOOL TAGS

| Model | ETV | ETD | ETP | Ordering No. |
|--------------------|--------------------------------------|------------------|-------------|--------------|
| TLS ST Tag 32 U1 | – | – | ST32, STB32 | 8433 1030 10 |
| TLS ST Tag 61-S U1 | ST31, ST61 28-50, STB32, STB62 30-50 | ST31, ST61 15-30 | – | 8433 1030 20 |
| TLS ST Tag 61-L U1 | ST61 70-200, STB62 70-100 | ST61 50-120 | – | 8433 1030 30 |
| TLS ST Tag 81-S U1 | ST81 50 | ST81 30 | – | 8433 1030 40 |
| TLS ST Tag 81-L U1 | ST81 70-200 | ST81 50-120 | – | 8433 1030 50 |
| TLS ST Tag 101 U1 | ST101 | ST101 | – | 8433 1030 60 |



TLS Tool tag

I/O DEVICE MODULE

| Model | ETV | ETD | Ordering No. |
|--------|------------------|------------------|--------------|
| ST61-S | ST31, ST61 28-50 | ST31, ST61 15-30 | 8433 0617 12 |
| ST61-L | ST61 70-200 | ST61 50-120 | 8433 0617 22 |
| ST81-S | ST81 50 | ST81 30 | 8433 0617 32 |
| ST81-L | ST81 70-200 | ST81 50-120 | 8433 0617 42 |
| ST101 | ST10 | ST10 | 8433 0617 52 |



I/O device module

Optional Accessories

PROTECTION

| Model | Ordering No. |
|--|--------------|
| Scanner protection ST61-S >50, ST31/ST32 | 4220 2762 10 |
| Selector protection | 4220 2917 06 |
| I/O device protection | 4220 2917 06 |
| TLS ST tag protection | 4220 2917 06 |



Scanner and TLS ST tag protection

FRONT BUTTON

| Model | ETV | ETD | Ordering No. |
|--------|------------------|------------------|--------------|
| ST61-S | ST31, ST61 28-50 | ST31, ST61 15-30 | 4220 3184 90 |
| ST61-L | ST61 70-200 | ST61 50-120 | 4220 3184 91 |
| ST81-S | ST81 50 | ST81 30 | 4220 3184 92 |
| ST81-L | ST81 70-200 | ST81 50-120 | 4220 3184 93 |
| ST101 | ST10 | ST10 | 4220 3184 94 |
| STR-S | STR31/STR61 <50 | STR31/STR61 <50 | 8436 6199 30 |
| STR-L | STR61 >50 | STR61 >50 | 8436 6199 32 |



Front button

ADJUSTABLE HEADLIGHTS

| Model | ETV | ETD | Ordering No. |
|--------|------------------|------------------|--------------|
| ST61-S | ST31, ST61 28-50 | ST31, ST61 15-30 | 4220 3292 94 |
| ST61-L | ST61 70-200 | ST61 50-120 | 4220 3292 95 |
| ST81-S | ST81 50 | ST81 30 | 4220 3292 96 |
| ST81-L | ST81 70-100 | ST81 50-120 | 4220 3292 97 |
| ST101 | ST10 | - | 4220 3292 98 |
| STR-S | STR31/STR61 <50 | STR31/STR61 <50 | 8436 6199 40 |
| STR-L | STR61 >50 | STR61 >50 | 8436 6199 42 |



Adjustable headlights

TELESCOPIC FRONT PART

| Model | mm | Ordering No. |
|--------------------|----|--------------|
| ST101 ETP 200 | 25 | 4220 4592 80 |
| ST101 ETP 500 | 40 | 4210 3781 81 |
| ST101 ETP 750/1000 | 50 | 4210 3788 80 |
| ST101 ETP 1500 | 50 | 4210 3788 81 |

MOUNTING RINGS FOR STR

| Model | Ordering No. |
|---------------|--------------|
| Upper ring -S | 8436 6199 50 |
| Upper ring -L | 8436 6199 52 |
| Lower ring -S | 8436 6199 60 |
| Lower ring -L | 8436 6699 62 |

Optional Accessories

REACTION BARS

| Spline dia mm | Square drive size mm/in | CC distance mm | Ordering No. |
|--|-------------------------|----------------|--------------|
| Steel bar | | | |
| Spline 1 | 268/36/18 | | 4210 1798 01 |
| Spline 2 | 270/35/10 | | 4220 1903 00 |
| Spline 3 | 400/56/12 | | 4210 2219 80 |
| Spline 4 | 500/62/15 | | 4210 2183 80 |
| Spline 5 | 500/62/15 | | 4210 2726 80 |
| Spline 6 | 560/80/15 | | 4220 1200 01 |
| Spline 7 | 500/100/20 | | 4210 3899 02 |
| Spline 8 | 500/150/20 | | 4210 3899 03 |
| Spline 9 | 500/85/20 | | 4210 3899 80 |
| Ø 26 mm | 270/34/8 | | 4220 3491 00 |
| Square steel bracket | | | |
| Spline 3 | 100/50/12 | | 4210 2219 03 |
| Spline 4 | 125/65/16 | | 4210 2183 01 |
| Spline 5 | 125/65/16 | | 4210 2726 01 |
| Spline 6 | 200/100/15 | | 4220 1200 00 |
| Spline 7 | 250/150/20 | | 4220 1445 00 |
| Spline 8 | 250/160/20 | | 4220 1972 91 |
| Spline 9 | 150/85/20 | | 4210 3899 01 |
| Ø 24 mm | 100/60/8 | | 4220 1029 00 |
| Ø 26 mm | 100/60/8 | | 4220 1029 02 |
| Ø 28 mm | 100/60/8 | | 4220 1029 01 |
| Triangular steel bracket | | | |
| Spline 2 | 73/72/14 | | 4220 2137 02 |
| Spline 3 | 82/80/15 | | 4220 2137 03 |
| Spline 6 | 112/109/15 | | 4220 2137 06 |
| Spline 6 | 150/145/20 | | 4220 2137 16 |
| Sliding drive reaction bar | | | |
| Spline 3 | 1/2 | 70-120 | 4210 4481 83 |
| Spline 3 | 3/4 | 70-120 | 4210 4481 63 |
| Spline 3 | 1/2 | 82-218 | 4210 4616 83 |
| Spline 3 | 3/4 | 82-218 | 4210 4616 63 |
| Spline 4 | 3/4 | 76-126 | 4210 4481 84 |
| Spline 4 | 3/4 | 82-218 | 4210 4616 84 |
| Spline 5 | 1 | 80-125 | 4210 4481 85 |
| Spline 5 | 1 | 82-218 | 4210 4616 85 |
| Spline 6 | 3/4 | 120-170 | 4210 4481 86 |
| Spline 9 | 1 | 80-130 | 4210 4481 89 |
| Spline 9 | 1 | 80-280 | 4210 4616 89 |
| S-Type reaction bar | | | |
| Spline 3 | 110/18/12 | | 4210 4480 03 |
| Spline 4 | 120/22/15 | | 4210 4480 04 |
| Spline 5 | 130/25/15 | | 4210 4480 05 |
| Spline 6 | 125/25/15 | | 4210 4480 06 |
| Spline 7 | 170/40/20 | | 4210 4480 07 |
| Spline 8 | 200/65/20 | | 4210 4480 08 |
| Spline 9 | 160/40/20 | | 4210 4480 09 |
| L-Type aluminum bar | | | |
| Spline 3 | 266x300/29/15 | | 4210 2219 08 |
| Spline 4 | 144x150/42/15 | | 4210 2183 08 |
| Straight aluminum bar | | | |
| Spline 3 | L = 400 | | 4210 2219 01 |
| Extended sliding drive reaction bar | | | |
| Spline 5 | 1 | 68-112 | 4210 4498 80 |
| Extended sliding tube reaction bar | | | |
| Spline 5 | 1 | 68-112 | 4210 4498 82 |
| Bracket stepped | | | |
| Spline 1 | 70/36/13 | | 4210 1798 02 |
| Spline 2 | 70/41/14 | | 4210 2134 02 |



Steel bar



Square steel bracket



Triangular steel bracket



Sliding drive reaction bar



S-Type reaction bar



L-Type aluminum bar



Straight aluminum bar



Extended sliding drive reaction bar

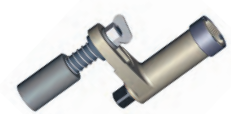

Extended sliding tube reaction bar



Bracket stepped

Error-proofing through intuitive control of the assembly process

Atlas Copco advanced controllers and software provide intuitive monitoring and control of tightening operations performed using Atlas Copco electric assembly tools. Assembly process control and quality assurance is made easy by advanced control functions. The system guides the operator through the assembly process, avoiding mistakes that can result in costly quality problems.

POWER FOCUS 4000

The Power Focus range controls tools from the Tensor DS, ST, SR, STR, STB and ETX families. With its built-in functions, it also participates in controlling the station or line segment. The Power Focus and associated software packages provide easy-to-understand information for everyone, from operators to plant managers.

The Power Focus is based on standard hardware and software components which, when combined, will fulfill all demands, from the most basic stand-alone installation to full integration into the factory network. The modules fit together using the “plug-and-play” concept.

Assembly process control and quality assurance is made easy by advanced control functions. On receipt of assembly information, the Power Focus automatically selects the correct tightening sequence and parameters. The operator is guided through the process, avoiding mistakes that can result in costly quality problems.

PROGRAMMING SOFTWARE TOOLS-TALK PF

ToolsTalk PF is the user-friendly tool that enables you to communicate with your Power Focus tool controller. It makes programming and process analysis of a tightening station simple.

POWER FOCUS 600

The Power Focus 600 is compatible with the Tensor ES tools and is the perfect choice for quality critical assembly. It comes in one single hardware version regardless of which tool model or functionality level is used. Its powerful industrial design gives a reliable process that will speed up your tightening operations.

Thanks to the intuitive interface and the fact that it's so easy to use you can set up and run a new system from the box in minutes. External computer software is no longer required since you can

browse in using a web HMI. The intuitive interface and color screen provide clear operator feedback.

Smart software management will guarantee highest possible uptime. Upgrade your controller in a few seconds using only a USB stick.

POWER FOCUS 6000

The Power Focus 6000 is compatible with STR, ST, STB, SR and ES and is the perfect choice for safety critical assembly. It comes in one single hardware version regardless of which tool model or functionality level is used. Its powerful industrial design gives a reliable process that will speed up your tightening operations.

The Power Focus 6000 is easy to use to use due to its 7 inch touch screen and intuitive software. The web HMI enables you to configure and monitor the controller from any device with a web browser. Smart software management will guarantee highest possible uptime. Upgrade your controller in a few seconds using only a USB stick.

TENSOR DS/DL DRIVES

Tensor DS nutrunners and DL screwdrivers have been developed to give you the benefits of controlled tightening and advanced electric systems throughout your assembly operations.

Their simplicity, reliability, outstanding flexibility and accuracy, can significantly reduce your assembly costs and improve overall productivity.

A suitable choice for quality critical applications, the Tensor DS and DL series have a proven track record in many industries, including aerospace, automotive, construction, white goods and electronics.



POWER FOCUS 600

The Power Focus 600 controller takes quality critical assembly to the next level. Setting up and using an electric system has never been easier. And, by switching from pneumatic tools, you can reduce your energy consumption by up to 85%. Unbelievable but true – we call it easy transformation!

EASY

Set up and run a new system from the box in minutes. Computer software is no longer required. Intuitive interfaces enable real-time analysis and fast reaction if needed.

EFFICIENT

Same controller hardware regardless of tool model. Powerful industrial design gives a reliable process to maximize uptime and speed up your tightening operations.

ERGONOMIC

Both hardware and software is intuitive, giving clear operator feedback on the screen.



Power Focus 600

| Model | Ordering No. |
|-----------------------------------|--------------|
| Drive unit | |
| Power Focus 600 with remote start | 8436 3700 01 |
| IAM | |
| IAM Joint Control | 8436 0900 01 |
| IAM Station Control | 8436 0900 05 |

FUNCTIONALITY OVERVIEW

| | IAM Joint Control | IAM Station Control |
|---|----------------------|------------------------|
| Functionality | | |
| Number of Psets | 1 | 16 |
| Batch sequence | 1 | 16 |
| Lock on reject | x | x |
| Strategies and options | | |
| Torque control | x | x |
| Torque control and angle monitoring | x | x |
| Configurable limits for torque and angle | x | x |
| Rotate spindle forward/reverse | x | x |
| TurboTight | - | x |
| Two Step | x | x |
| Quick Step | x | x |
| Three Step | x | x |
| CW / CCW operation | x | x |
| Complete re-hit detection | x | x |
| Self tap | x | x |
| Process information and service | | |
| Tightening data storage (Torque, Status OK/NOK, NOK reason) | 30 | 1000 |
| Torque-time trace | x | x |
| Event log | 1000 | 1000 |
| Hardware and connectivity | | |
| Web-browser client programming | x | x |
| Read and write programming via remote Ethernet | - | x |
| Tightening data via local USB | x | x |
| Tightening data via remote Ethernet | - | x |
| Controller SW upgrade via local USB | x | x |
| Controller SW upgrade via remote Ethernet | - | x |
| 1D/2D Barcode reader for selection | - | x |
| Remote start | x | x |
| Configurable I/O | x | x |
| Stacklight | x | x |
| Socket selector | x | x |
| Operator panel | x | x |

POWER FOCUS 6000

This all new fastening solution from Atlas Copco takes productivity, ergonomics, quality and environmental impact to entirely new levels. And all this with the most user-friendly experience ever.

Enjoy the benefits of a system providing a unique operator experience, with superior quality control and the most flexible integration. The Power Focus 6000 and Tensor STR is the perfect option for your safety critical assembly processes!

MULTITOOL CONTROLLER

The Power Focus 6000 increases your flexibility in rebalancing assembly lines. Now you are able to connect up to 6 tools to the same controller. Giving you a simpler installation with less cables, hardware components and network drops. Add to that the lower power consumption, less floor space utilization and a much lower environmental footprint, the benefits are obvious.

COMMON CONTROLLER

One platform for handheld and fixtured tools. The Power Focus 6000 reduces your inventory costs and training requirements.

Easy to connect and configure back up tools, using the same programming interface. More compatible solutions will continuously be deployed. And the Power Focus 6000 will be your common controller for all tools and needs.

IAM – INTELLIGENT APPLICATION MODULE

Intelligence in the palm of your hand. Software, tightening data and configuration – carry all important information with you in a future proof portable module. Easy to upgrade and stable with a rapid back-up function. Two software areas allow for smart software management. Allowing a much safer upgrade process, always giving the possibility to switch between two software versions.



Power Focus 6000

| Model | Ordering No. |
|--------------------------------|--------------|
| Drive unit Power Focus 6000 | 8436 1800 02 |

Functionality Overview Controllers - DS/DL, Power Focus 4000

| General Functionality Level / RBU Runs Tool Types | DS / DL | | | Power Focus 4000 | | | | |
|---|-----------|------------------|---------------------|------------------|---------------------|---------------------|-------------------|----------|
| | Box DS | Basic DS / DL | Advanced DS / DL | DS DS | Bronze ST/SR/STR | Silver ST/SR/STR | Gold ST/SR/STR | X ETX |
| Tensor controllers | | | | | | | | |
| Compact hardware | x | x | x | x | x | x | x | x |
| LED display | | x | x | x | x | x | x | x |
| 6 button keyboard | | x | x | x | x | x | x | x |
| Graph hardware | | | | | | x | x | x |
| LCD display | | | | | | x | x | x |
| Full keyboard | | | | | | x | x | x |
| Functionality | | | | | | | | |
| Number of tools | 1 | 1 | 1 | 1 | 1 | 1 | 1 | 1 |
| Number of Psets | 1 | 1 | 10 | 64 | 64 | 250 | 250 | 250 |
| Batch count | x | x | x | x | x | x | x | x |
| Open end spanner | x | DS only | DS only | x | x | x | x | x |
| Quick programming | x | x | x | x | x | x | x | x |
| Cross thread / Rehit detection | x | x | x | x | x | x | x | x |
| Tool service indicator | x | x | x | x | x | x | x | x |
| Autoset | x | x | x | x | x | x | x | x |
| Lock on reject | x | x | x | x | x | x | x | x |
| Line control | | | x | x | | x | x | x |
| Transducer torque traceability | | | | | x | x | x | x |
| Tightening status storage (default) | | | | 5 000 | 5 000 | 5 000 | 5 000 | 5 000 |
| Tightening data storage (default) | | | | | 5 000 | 5 000 | 5 000 | 5 000 |
| MultiStages | | | | 8 | | 8 | 8 | 8 |
| Trace storage | | | | | 8 | 8 | 8 | 8 |
| Real time statistics | | | | | x | x | x | x |
| SPC | | | | | x | x | x | x |
| RBU | | | | x | x | x | x | x |
| Bar code reading | | | | x | | x | x | x |
| ID input to select Pset | | | | x | | x | x | x |
| Job function | | | | x | | x | x | x |
| Number of jobs (default) | | | | 32 | | 99 | 99 | 99 |
| ID input to select job | | | | x | | x | x | x |
| Logic Configurator (4000 only) | | | | x | | x | x | x |
| Cell programming | | | | x | | x | x | x |
| Label printer (via Open protocol) | | | | x | | x | x | x |
| Cell Job | | | | | | | x | x |
| Strategies and options | | | | | | | | |
| Two stage/Quick step/Ergoramp | x | x | x | x | x | x | x | x |
| Torque control and angle monitoring | x | x | x | x | x | x | x | x |
| DS control | x | x | x | x | | x | x | x |
| Auto zoom step | x | x | x | x | x | x | x | x |
| CW / CCW operation | x | x | x | x | x | x | x | x |
| Rundown angle monitoring | x | x | x | x | x | x | x | x |
| Self tap / PVT monitoring | x | x | x | x | x | x | x | x |
| Reverse angle | x | x | x | x | x | x | x | x |
| Rotate spindle | x | x | x | x | x | x | x | x |
| Click wrench input | | | | | x | x | x | x |
| Torque and angle control | | | | | x | x | x | x |
| Angle control and torque monitoring | | | | | x | x | x | x |
| Current monitoring | | | | | x | x | x | x |
| Post view torque | | | | | | x | x | x |
| Yield control (PF 4000 and ETX combination only) | | | | | | | x | x |
| StepSync, SynchroTork (PF 4000 only) | | | | | | | x | x |
| Home position | | | | | | | x | x |
| Snug gradient | | | | | | | x | x |
| I/O | | | | | | | | |
| RS232 programming port | x | x | x | x | x | x | x | x |
| USB port (PF 4000 only) | | | | x | x | x | x | x |
| Discrete I/O | x | x | x | x | x | x | x | x |
| Remote start | x | x | x | x | x | x | x | x |
| Socket selector (optional) | | | x | x | x | x | x | x |
| RE Alarm (optional) | | | x | x | x | x | x | x |
| Parallel printer port | | | | x | x | x | x | x |
| I/O Expander (optional) | | | | x | x | x | x | x |
| Expandable I/O (up to 124 in / 124 out) | | | | x | x | x | x | x |
| Operator ID card input | | | | x | | x | x | x |
| Fieldbus card | | | | Optional | | Optional | Optional | Optional |
| RS232 bar code reader port | | | | x | | x | x | x |
| Easily programmed fieldbus protocol | | | | x | | x | x | x |
| Ethernet port for remote prog | | | | x | | x | x | x |
| Ethernet port for data collection | | | | OK-NOK | | x | x | x |
| Protocols | | | | | | | | |
| Open protocol serial | | | | x | x | x | x | x |
| Open protocol Siemens 3964R serial | | | | x | x | x | x | x |
| Open protocol Ethernet | | | | x | | x | x | x |

DRIVE FUNCTIONALITY OVERVIEW

Used to control and monitor tools, the DS and DL drives provide a high degree of functionality with minimal setup and configuration. The DS drive runs with the Tensor DS nutrunners and the DL drive is used together with Tensor DL screwdrivers.

TENSOR DS AND DL REDUCE COSTS

The Tensor DS and DL systems reduce costs by offering three major benefits:

ELIMINATION OF ASSEMBLY PROBLEMS

Through its control and monitoring functionality, Tensor DS/DL will bring you closer to zero-fault production. By alerting the operator to the most common errors before they continue down the line, the system ensures high-quality end products, and saves you a fortune in reworking costs.

ONETOOL FOR SEVERAL APPLICATIONS

The Tensor DS/DL can be set with up to 10 different torque settings making it possible to use the same tool for several applications. This reduces operating costs and allows a cleaner design of the work area.

TENSOR DS/DL IMPROVES PRODUCTIVITY

Tensor DS/DL tools shorten the cycle times through high speed and power. The controller calculates and monitors torque through the highly accurate DigiTork algorithm. The tools are equipped with angle encoders monitoring the rundown angle as well as the tightening angle. Combining torque and angle monitoring you will detect if something is wrong with the joint, guaranteeing quality.



DS Drive



DL Drive

| Model | Ordering No. |
|-------------------|--------------|
| DL Drive | |
| D303-DL Basic | 8433 4850 48 |
| D313-DL Advanced | 8433 4850 33 |
| DS Drive | |
| D312-DS4 Advanced | 8433 0820 33 |
| D312-DS7 Advanced | 8433 0822 33 |
| D312-DS9 Advanced | 8433 0824 33 |

ADVANCED PROCESS CONTROL AND MONITORING FUNCTIONS

Power Focus is a modular range of controllers, with full flexibility, designed for applications ranging from single spindle hand-held operations to fixtured multiple nutrunning systems. Advanced process control and monitoring functions make it easy to view and collect data using the Internet infrastructure.

- Choose your controller – either Graph or Compact.
- Choose your RBU software key to run a tool.
- Choose from various ways to use the controller, as a stand-alone or in a network.
- Run many different kinds of tool, standard, FS, crowfoot or open tools.
- Realtime statistics analysis.
- Error-proofing solution.
- Advanced tightening control and/or monitoring method.
- Trace view.
- Logic configurator.
- Can handle different level of communication.

The Power Focus 4000 is available in two versions, Compact and Graph. The difference between them is the user interface, where the Graph features the color display and a full keyboard.

COMPACT

This version offers full functionality at a lower cost, but requires a PC with the ToolsTalk PF software for process set-up.

GRAPH

With the Graph hardware, you have full stand-alone programming possibilities. When networked, the Graph can function as a programming terminal for other Power Focus units.

RBU CUTS DOWNTIME

Atlas Copco's patented Rapid Backup Unit (RBU) concept transfers functionality to a non-configured hardware unit, ensuring that hardware can easily be upgraded should functionality requirements change. The RBU also acts as back-up for programming and configuration. If a change of hardware is required, just fit the RBU to the new hardware, switch on the unit and you're ready. All programming and network configurations are transferred in seconds. The RBU cuts downtime to a minimum.



Compact



Graph

POWER FOCUS 4000 FOR TENSOR DS, ST, SR, STR, STB AND ETX

| Model | Ordering No. |
|------------------------------|--------------|
| Power Focus 4000 W 10 | |
| PF 4000-G-HW | 8433 7100 00 |
| PF 4000-C-HW | 8433 7100 05 |
| PF 4000-G-DN- HW | 8433 7140 00 |
| PF 4000-C-DN-HW | 8433 7140 05 |
| PF 4000-G-PB-HW | 8433 7142 00 |
| PF 4000-C-PB-HW | 8433 7142 05 |
| PF 4000-G-CC-HW | 8433 7143 00 |
| PF 4000-C-CC-HW | 8433 7143 05 |
| PF 4000-G-PN-HW | 8433 7148 00 |
| PF 4000-C-PN-HW | 8433 7148 05 |
| PF 4000-G-EIP-HW | 8433 7149 00 |
| PF 4000-C-EIP-HW | 8433 7149 05 |

IRC FOCUS FOR STWRENCH AND TENSOR STB

| Model | Ordering No. |
|-----------------------|--------------|
| IRC Focus W 10 | |
| IRC FOCUS-B-G-HW | 8433 6500 00 |
| IRC FOCUS-B-C-HW | 8433 6500 02 |
| IRC FOCUS-B-G-DN-HW | 8433 6500 04 |
| IRC FOCUS-B-C-DN-HW | 8433 6500 06 |
| IRC FOCUS-B-G-PB-HW | 8433 6500 12 |
| IRC FOCUS-B-C-PB-HW | 8433 6500 14 |
| IRC FOCUS-B-G-PN-HW | 8433 6500 24 |
| IRC FOCUS-B-C-PN-HW | 8433 6500 26 |
| IRC FOCUS-B-G-EIP-HW | 8433 6500 28 |
| IRC FOCUS-B-C-EIP-HW | 8433 6500 30 |

POWER FOCUS 4002 FOR TENSOR SL

| Model | Ordering No. |
|------------------------------|--------------|
| Power Focus 4002 W 10 | |
| PF 4002-G-HW | 8433 3100 00 |
| PF 4002-C-HW | 8433 3100 05 |
| PF 4002-G-DN-HW | 8433 3140 00 |
| PF 4002-C-DN-HW | 8433 3140 05 |
| PF 4002-G-PB-HW | 8433 3142 00 |
| PF 4002-C-PB-HW | 8433 3142 05 |
| PF 4002-G-PN-HW | 8433 3148 00 |
| PF 4002-C-PN-HW | 8433 3148 05 |
| PF 4002-G-EIP-HW | 8433 3149 00 |
| PF 4002-C-EIP-HW | 8433 3149 05 |

CONTROLLER FUNCTIONALITY

| Hardware key | Ordering No. |
|--------------|--------------|
| RBU-Bronze | 8433 0010 10 |
| RBU-Silver | 8433 0015 20 |
| RBU-Gold | 8433 0020 20 |
| RBU-DS | 8433 0005 10 |
| RBU-X | 8433 0080 20 |



RBU

SPINDLE SYNCHRONIZATION

All Atlas Copco tightening spindles are easily fixtured using our standard range of Express mechanics. The StepSync and SynchroTork tightening strategies give various levels of spindle synchronization during clamp force build-up. Communication between the controllers in the cell or group takes place via the I/O bus. Depending on user-interface preferences and budget, the SyncMaster may be a Compact or Graph hardware unit.

MULTISTAGE FUNCTIONALITY REDUCES RELAXATION

The inherent "MultiStage" functionality permits the combination of up to eight different parameter sets in a linear sequence. The entire process is activated with just one press of the tool trigger. For joint conditioning, fasteners can be run down to a pre-torque value, backed off by a configurable number of degrees and then re-tightened to the desired final torque. This advanced functionality is ideal for reducing relaxation in a joint.

CELL NETWORKING GIVES PROCESS SECURITY

The Cell concept allows for Ethernet networking without a PC, and offers overall station process control at a lower cost.

INTEGRATED WAYS TO COMMUNICATE

CONTROLLER LEVEL

Realtime communication over I/O bus independent of the factory net.

FIELD BUS LEVEL

The common industry field buses are supported, for example Profibus and Ethernet IP.

CELL LEVEL

The cell is a key concept in the system design. It is a cluster of max. 20 controllers networked together via built-in Ethernet TCP/IP. No need for use of a PC.

FACTORY LEVEL

Power Focus can be integrated with the factory Ethernet network which enables easy access and reporting anywhere in the plant.

INTERNET LEVEL

Worldwide communication is a matter of giving access through a factory network gateway to Power Focus.



Tensor spindles are easily fixtured using our standard range of Express mechanics. The control strategies StepSync and SynchroTork synchronize Tensor spindles to provide consistent clamp forces over the entire component mating face.

A Cell consists of up to 20 units, where the Master controls the process of all Members in the tightening station, and communicates process data as a single interface point.

ADVANCED STATISTICS FOR BETTER QUALITY CONTROL

Data is continuously collected and analyzed, and can be presented as statistics on, e.g., the Graph color display. Diag-

nostics and statistical alarms such as SPC monitor charts, and capability (Cpk) alarms highlight changes and trends in the assembly process. Effective information and SPC are good motivators, and encourage operators to adopt a proactive approach to monitoring the quality of the assembly process.

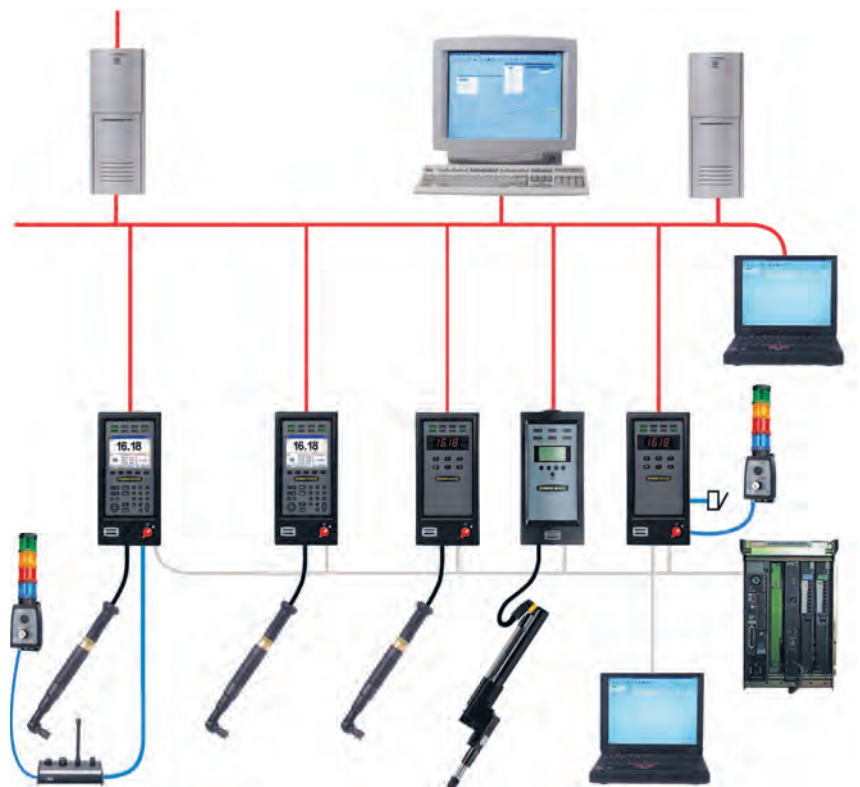

Discrete I/O, I/O bus, Fieldbus, Compact, Graph, PC, access router, host database.

TOOLSTALK PF

ToolsTalk PF provides tightening parameter set-up, fieldbus and Logic Configurator set-up, plus customized reporting and presentation of statistics. With a simple click, results can be exported into other commercial file formats.

ToolsTalk communicates with the PowerFocus via Ethernet, USB or serial RS232. If you are networking from your office desk, ToolsTalk PF allows for quickest access to the different control units connected.



TOOLSTALK POWER FOCUS

| Model | Ordering No. |
|--|--------------|
| ToolsTalk W14 | |
| 1-user license | 8092 1191 01 |
| 5-user license | 8092 1191 05 |
| 10-user license | 8092 1191 10 |
| Plant license | 8092 1191 19 |
| ToolsTalk W10 | |
| 1-user license | 8092 1190 01 |
| 5-user license | 8092 1190 05 |
| 10-user license | 8092 1190 10 |
| Plant license | 8092 1190 99 |
| ToolsTalk upgrade to W14 | |
| 1-user license | 8092 1191 11 |
| 5-user license | 8092 1191 15 |
| 10-user license | 8092 1191 20 |
| Plant license | 8092 1191 29 |
| ToolsTalk PF W07 upgrade to W10 | |
| 1-user license | 8092 1190 31 |
| 5-user license | 8092 1190 35 |
| 10-user license | 8092 1190 40 |
| Plant license | 8092 1190 49 |

| Model | Ordering No. |
|--|--------------|
| ToolsTalk DS/DL | |
| Swedish | 8092 1138 60 |
| English | 8092 1138 62 |
| German | 8092 1138 64 |
| French | 8092 1138 66 |
| Spanish | 8092 1138 68 |
| Italian | 8092 1138 70 |
| Power Focus controller software | |
| PF World 10 sticker, (12 package) | 4222 0820 25 |

Atlas Copco's Station Solutions reduce cost and ensure quality

As part of Atlas Copco's Quality Integrated Fastening (QIF) concept we offer complete error proofing stations. These are created by combining our advanced tightening equipment with standard Atlas Copco hardware and software components. Integrated error-proofing assembly stations help you avoid costly reworking, raise productivity and ensure quality on your production line.

Atlas Copco is one of the few suppliers able to offer a range of products comprehensive enough to build a fully integrated assembly station. QIF error-proofing stations offer the following benefits:

- Increased product quality.
- Standard modules reduce project and set-up time.
- Fast line re-balancing with standard interfaces.
- Higher productivity due to improved operator guidance.
- Full after sales support from Atlas Copco.

Atlas Copco is one of a few suppliers able to offer such a large range of products to build a fully integrated assembly station.

FAST, EASY SET-UP

Most QIF products can easily be connected to Power Focus and Pulsor Focus using one I/O Bus cable, and to PowerMACS using one MACS I/O cable. They can be configured using standard Atlas Copco software ToolsTalk. This user-friendly PC software makes programming very simple.

A key factor that makes QIF products so well accepted by users is their logical and intuitive set-up. By combining QIF products with ToolsTalk Logic Configurator, it is possible to make logical diagrams with inputs and outputs that further enhance the flexibility of the products.



A complete offering

FEEDBACK

Higher quality can be achieved by giving audio and/or visual feedback about the assembly process to the operators. Time and costs can be saved by reducing reworking and avoiding faulty products leaving the production line. For feedback use Atlas Copco's Stacklights.



ESL-04 Compact and ESL-04 Standard

VARIANCE SUPPORT

Productive assembly lines demand efficient operators. These should be supported with appropriate tools providing feedback for all actions. This will save time changing program settings and when performing reworkings in station. For variance support use Atlas Copco's Selectors and Operator Panels.



Selector 4, selector for Large Sockets and Operator Panel Basic

OPERATOR GUIDANCE

Flexible assembly lines demand different products to be assembled at the same station. It is possible to reduce the number of decisions taken by the operator by providing direct instructions on a screen with photos and texts of the assembly process. For operator guidance use Atlas Copco's HMI's (Human Machine Interface).



MiniDisplay 2

PROCESS MONITORING

Storing production data for documentation and further analysis is a key factor for traceability. Process improvements can be made by analyzing data. This contributes to increasing quality and boosting productivity by minimizing the number of recalls. For process monitoring use Atlas Copco's ToolsNet 8.



ComNode 3

REDUCING THE COST OF PERIPHERALS



SELECTORS

Socket and bit selectors minimize the risk of errors relating to product diversity by automatically selecting correct torque according to the socket or bit selected.

STACKLIGHTS

Lamps and a buzzer give clear feedback and a key switch can be used to acknowledge errors. This arrangement enables you to detect errors at the workstation and correct them in station instead of further down the line.

OPERATOR PANELS

Command buttons and integrated lamps provide a highly effective operator interface and enable manual selection of various program settings.

HMI'S

Mini display with Operator Guidance software shows photo of the product on the screen, clearly indicating joints to be tightened and giving build instructions.

WEAFLEX

WEAFlex is a Wireless Ethernet Adapter (WEA) supporting Wireless LAN 802.11b/g interface. Powered by the controller (24vDC), WEAFlex converts the Ethernet port to a Wireless port. This enables communication with ToolsNet for data collection, ToolsTalk for remote programming without USB or Serial cables, production systems or just to exchange information with another controller for a cell job or synchronization.



MODULARITY

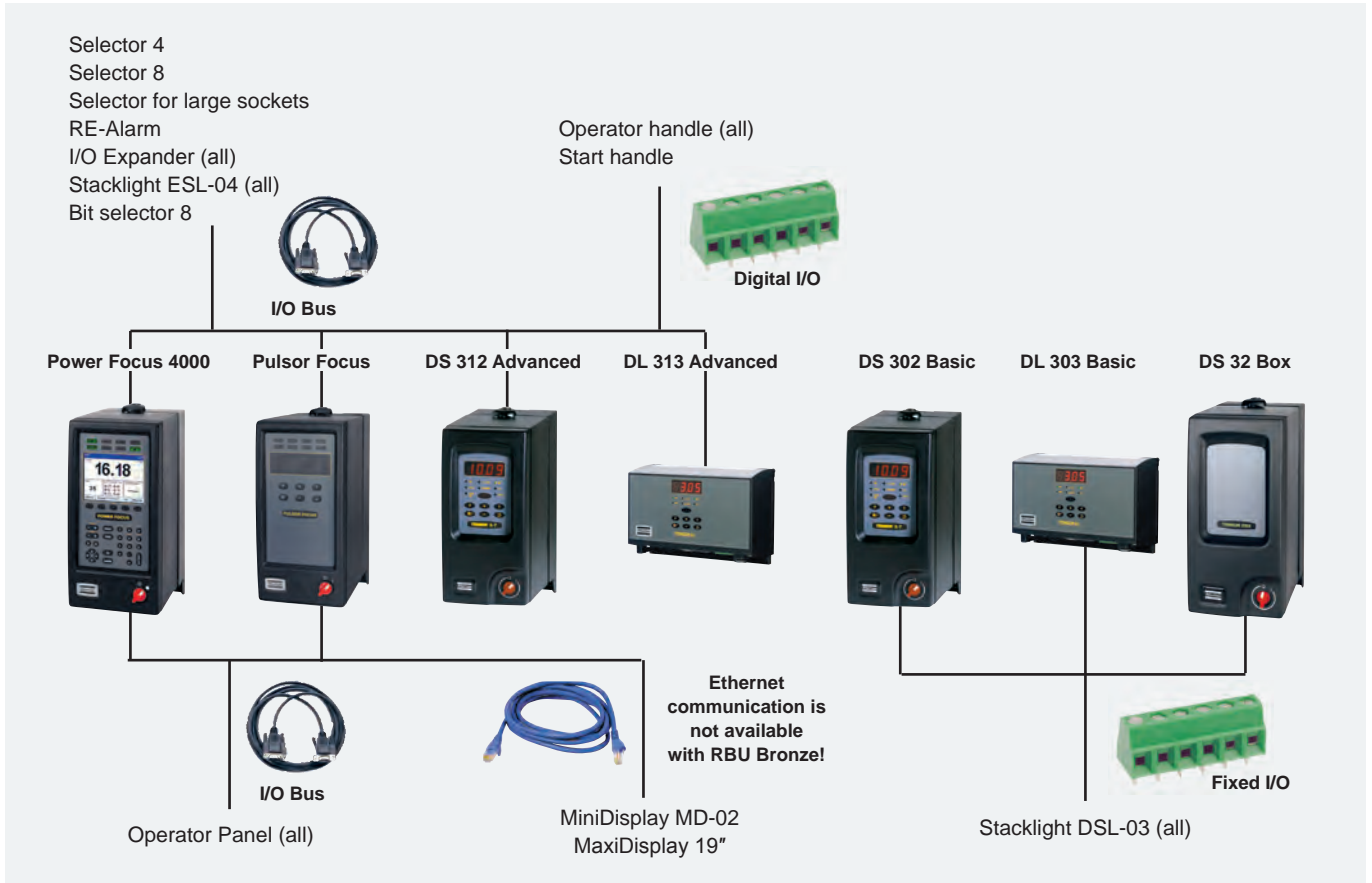

| Model | Ordering No. |
|----------------------------|--------------|
| Remote Start | |
| Selector 4 | 8433 0610 04 |
| Selector 8 | 8433 0610 08 |
| Selector for large sockets | 8433 0610 44 |
| Rotary selector | 8433 0606 15 |
| Bit selector 8 | 8433 0612 08 |
| double ^a | 4222 0933 92 |
| single ^b | 4222 0933 91 |

^a Only compatible with Bit selector.
^b Only compatible with Socket selector 4 and 8.

| I/O Expanders | |
|----------------------|--------------|
| Open | 8433 0564 39 |
| Sealed | 8433 0564 45 |

| Stacklights | |
|-------------------------|--------------|
| ESL-04 Standard | 8433 0570 13 |
| Rotating red | 8433 0570 30 |
| Rotating yellow | 8433 0570 35 |
| Siren | 8433 0570 40 |
| Compact | 8433 0570 16 |
| DSL-03 with push button | 8433 0570 10 |
| with blanking plugs | 8433 0570 11 |

| Operator panel | |
|-----------------------|--------------|
| Advanced | 8433 0565 00 |
| Basic | 8433 0565 10 |

| HMI's (Human Machine Interface) | |
|---|--------------|
| MiniDisplay -2 6.5", incl. Operator Guidance | 8435 3071 00 |
| MaxiDisplay 3 (19") excl. Operator Guidance | 8435 3070 20 |

| ComNode 3 | |
|-----------------------|--------------|
| ComNode 3 Touch (15") | 8433 2712 00 |

| Communication | |
|----------------------|--------------|
| WEAFlex - LAN | 8433 1010 00 |

| Remote Start | |
|-------------------------------------|--------------|
| Operator handle (ball joint/handle) | |
| - front/plastic | 8435 3030 00 |
| - front/rubber | 8435 3030 01 |
| - rear/plastic | 8435 3030 02 |
| - rear/rubber | 8435 3030 03 |
| Start handle | 4220 1391 91 |

| Cables | |
|-------------------------|--------------|
| Accessory cables | |
| I/O bus cable 0.5 m | 4222 0917 00 |
| 1 m | 4222 0917 01 |
| 3 m | 4222 0917 03 |
| 5 m | 4222 0917 05 |
| 10 m | 4222 0917 10 |
| 15 m | 4222 0917 15 |
| I/O Termination plug | 4222 0443 00 |

| M12-4 pin | |
|-----------------------|--------------|
| Female - Open end 5 m | 4243 0166 05 |
| Male - Female 5 m | 4243 0167 05 |
| 10 m | 4243 0167 10 |
| 15 m | 4243 0167 15 |

| Cables for WEAFlex (1 m) | |
|---------------------------------|--------------|
| Power24vDC, M12-5 pin | 4243 0286 80 |
| EthernetRJ45, M12-4 pin | 4222 1540 01 |

TLS

| Model | Ordering No. |
|--------------------|--------------|
| Tool Tags | |
| TLS ST Tag 32 U1 | 8433 1030 10 |
| TLS ST Tag 61-S U1 | 8433 1030 20 |
| TLS ST Tag 61-L U1 | 8433 1030 30 |
| TLS ST Tag 81-S U1 | 8433 1030 40 |
| TLS ST Tag 81-L U1 | 8433 1030 50 |
| TLS ST Tag 101 U1 | 8433 1030 60 |

| Product Tags (package of 5 units) | |
|--|--------------|
| TLS Compact Tag U1-63 | 8433 1026 05 |
| TLS Power Tag U1-65 | 8433 1025 05 |
| TLS GPS TAG U1-65 | 8433 1024 05 |



WEAFlex



Selector 4



Selector 8



I/O expander sealed



Selector for large socket



Stacklight DSL-03



Rotary selector



Stacklight ESL-04 Compact



Operator handle



Operator panel Advanced



Start handle

ToolsNet 8 is a data collection and process improvement software application for use with Power Focus, Pulsor Focus, PowerMACS and STWrench with support for other controllers over ToolsNet open protocol. Combined, these products provide total control of the assembly process, providing a platform for quality improvements. Historical data, statistics and capability indexes can be accessed at any time via a standard web browser such as Microsoft Internet Explorer. ToolsNet is the complete assembly process improvement tool.

TRACEABILITY MINIMIZES RECALL COSTS

The production can be followed in real-time through the dashboard or monitored through different reports such as the Result List report or Product List report which provides information of every tightening related to a specified period or product. In the event of warranty recalls, the result database provides access to critical information which can easily minimize the extent of any recall leading to an overnight payback on your investment.



THE RIGHT SOLUTION FOR YOUR NEEDS

ToolsNet 8 is divided in three different packages to cover different needs.

REPORTS

Take the first step in traceability by collecting all tightening results and storing them in a secure database system. Legal documentation and process improvements can be handled by running several pre-formatted reports specially designed to save user time and effort.

ALERT

Extend the usage of available information by collecting all production events as they occur on the assembly line, in real time. Generate reports to identify events that are happening often and trigger emails to the right personnel based on event distribution rules you create. Be always on the alert for quality variation and workstations that require preventative or corrective tool maintenance.

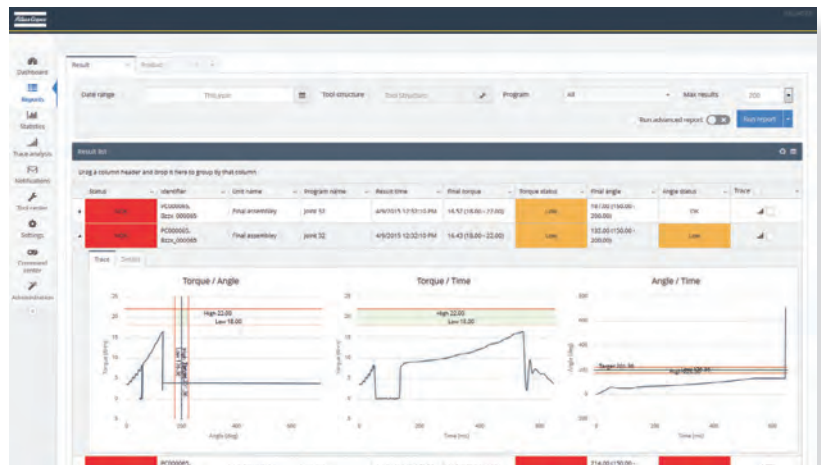

ANALYSIS

The analysis package adds advanced statistical capabilities making it possible to search for variations when it comes to large amounts of production data. Another feature that is added with the analy-

sis package is tool center which makes it possible to track detailed information about the tools that are used in production ensuring that they are serviced and calibrated on time.

| Software | Ordering No. | Upgrade Ordering No. |
|------------------------------|--------------|----------------------------|
| ToolsNet 8 - Reports | | |
| | | Upgrade¹ |
| 5 Spindle license | 8092 1710 05 | 8092 1810 05 |
| 10 Spindle license | 8092 1710 10 | 8092 1810 10 |
| 25 Spindle license | 8092 1710 25 | 8092 1810 25 |
| 50 Spindle license | 8092 1710 50 | 8092 1810 50 |
| 75 Spindle license | 8092 1710 75 | 8092 1810 75 |
| 125 Spindle license | 8092 1710 80 | 8092 1810 80 |
| 200 Spindle license | 8092 1710 85 | 8092 1810 85 |
| 350 Spindle license | 8092 1710 90 | 8092 1810 90 |
| 500 Spindle license | 8092 1710 95 | 8092 1810 95 |
| Plant Spindle license | 8092 1710 00 | 8092 1810 00 |
| ToolsNet 8 - Alerts | | |
| | | Upgrade² |
| 5 Spindle license | 8092 1711 05 | 8092 1811 05 |
| 10 Spindle license | 8092 1711 10 | 8092 1811 10 |
| 25 Spindle license | 8092 1711 25 | 8092 1811 25 |
| 50 Spindle license | 8092 1711 50 | 8092 1811 50 |
| 75 Spindle license | 8092 1711 75 | 8092 1811 75 |
| 125 Spindle license | 8092 1711 80 | 8092 1811 80 |
| 200 Spindle license | 8092 1711 85 | 8092 1811 85 |
| 350 Spindle license | 8092 1711 90 | 8092 1811 90 |
| 500 Spindle license | 8092 1711 95 | 8092 1811 95 |
| Plant Spindle license | 8092 1711 00 | 8092 1811 00 |
| ToolsNet 8 - Analysis | | |
| | | Upgrade³ |
| 5 Spindle license | 8092 1712 05 | 8092 1812 05 |
| 10 Spindle license | 8092 1712 10 | 8092 1812 10 |
| 25 Spindle license | 8092 1712 25 | 8092 1812 25 |
| 50 Spindle license | 8092 1712 50 | 8092 1812 50 |
| 75 Spindle license | 8092 1712 75 | 8092 1812 75 |
| 125 Spindle license | 8092 1712 80 | 8092 1812 80 |
| 200 Spindle license | 8092 1712 85 | 8092 1812 85 |
| 350 Spindle license | 8092 1712 90 | 8092 1812 90 |
| 500 Spindle license | 8092 1712 95 | 8092 1812 95 |
| Plant Spindle license | 8092 1712 00 | 8092 1812 00 |
| Operator guidance | | |
| 1 User license | 8092 1185 01 | |

¹ ToolsNet 4000 Reports is required.

² ToolsNet 4000 Alerts is required.

³ ToolsNet 4000 History is required.

NOTE: Check for availability on your market.

TOOL ACCESSORIES

Contents

| | |
|----------------------------------|-----|
| Introduction..... | 154 |
| TPS Controller | 156 |
| TPS Positioning Torque Arms..... | 157 |
| Torque arm SML T | 158 |
| Torque arm SMS T | 159 |
| Carbon arm SMC..... | 160 |
| Linear arm SML MK II..... | 161 |
| MicroTorque GHP | 162 |
| Torque arm accessories | 163 |
| Bits and power sockets..... | 167 |

Protect your most valuable resource

Operator health is important. If your operators work with hand-held electric or pneumatic tools, the last thing you want is for their health to suffer. However light the tool, when an operator performs repetitive tasks daily, often with incorrect posture, the tool seems to grow heavier by the hour. Add torque reaction from the tightening process, and the result can be hand-arm-shoulder disorders that may lead to injury and even premature retirement.

Give your operators an extra arm! Atlas Copco torque arms are labour-saving extensions of Atlas Copco hand-held tools that ensure accurate tightening, and raise individual productivity in your plant. Available for torques of up to 1000 Nm, these ingenious constructions are the perfect way to lighten the load when performing repetitive tasks on lines or benches.

EASE THE STRAIN

Atlas Copco torque arms take the strain off your operators, and allow maximum freedom of movement and flexibility. Wide fields of reach mean that the operator has a large working area without stretching.

FAST PAYBACK

Investing in torque arms is not such a major decision. With their benefits in terms of increased productivity and improved employee health, payback time is short.

LINEAR TORQUE ARMS RAISE PRODUCTIVITY IN GERMANY

At its plant in Alpen, in the lower Rhine area of Germany, Lemken GmbH & Co. KG manufactures agricultural machinery. Previously, a safety critical bearing block joint was tightened using an impact wrench, followed by a torque wrench to reach final torque. The torque values required were between 300 and 500 Nm.

SML TORQUE ARMS ABSORB REACTION FORCES

To improve productivity, Lemken installed an Atlas Copco Tensor DS electric angle nutrunner, mounted on SML 500 linear torque arms, to handle the task. The bolt is tightened to 300 Nm, then loosened 15 degrees and finally tightened to 300 Nm again. The SML 500 absorbs all reaction forces, and enables fast, accurate tightening, with good ergonomics for the operator.

PAYBACK WITHIN ONE YEAR

Although the plant only operates on a single-shift basis, Lemken recouped its investment within one year. The company is satisfied with the equipment and enthusiastic about the flexibility of Atlas Copco tools.

BASIC GUIDELINES FOR TORQUE ARMS

Tools used full days with a torque capacity shown in the table should always be used together with a torque arm in order to prevent work related injuries.

| | Straight | Pistol | Angle |
|------------------------|----------|--------|---------|
| Ergonomical optimized* | > 4 Nm | > 7 Nm | > 30 Nm |
| Conventional tools | > 3 Nm | > 5 Nm | > 20 Nm |

* Ergonomically optimized tools is electric tools with two step softstop, turbotight or fast clutch pneumatic tool on a hard joint.

TO CONSIDER

- However light or low torque, daily use of tools for repetitive tasks can result in hand/arm/shoulder disorders.
- On average a female operator can take 2/3 of the same force as her male colleague.
- Is there enough space for a torque arm at the workplace?
- Finished product quality improvement.
- With the use of a torque arm the arm will absorb all the reaction force from the tool and prevent the tool from spinning around its axis. To ensure highest possible accuracy of the clamp force a torque arm should be used to prevent movement of the tool.



TPS – Tool Positioning System

CONTROL THE SEQUENCE AND THE POSITION

With a TPS controller you are always sure that the operators tighten the joints in the correct sequence and the correct position. The TPS controller works together with the SML/SMS T-series positioning torque arms or the SMC POSI L/LA torque arms and tool controller. The torque arms are equipped with encoders, SMS T-series have 2 angle encoders and SML T-series have 1 linear encoder and 1 angle encoder. The SMC POSI L is equipped with 1 linear encoder to measure the distance the arm travels. SMC POSI LA is equipped with 2 encoders, to measure the distance the arm travel and the angle. The TPS works with digital I/Os for OK or NOK signals to the tool controller to determine the sequence and position of the tool, if the tool is out of position the tool will not start and when the tool is in position it will be able to start. After a correct tightening with OK signal from tool/controller the operator will receive an OK signal from the TPS and is able to start in the next position.

EASY PROGRAMMING

The TPS can use self learning programming, position the tool in the arm over the selected joint and confirm position, go to next joint with the tool/arm and do the same procedure. When all joints are selected validate the job sequence and the TPS is ready for its new job.

50 JOBS – 500 POSITIONS

The TPS can have up to 50 jobs and up to 500 positions (sequences). The TPS can send information to the tool controller to change Pset in the same job which means that it can be different torque settings in the same job and that the same joint can be tightened several times in the same job. When programming the TPS it can also be with different Psets for different jobs so that the operator always has the correct Pset from tool controller when the TPS job is selected.

FAST AND SMOOTH TO START TO INCREASE PRODUCTIVITY

A job can be started by the operator by pressing the start button on the TPS



control and if the TPS is set to Level in job start the operator only needs to push the start button once, when the job is finished with Level setting the same job starts automatically again. Jobs can also be started by a switch button, from tool controller or on timer from previous job.

STAND ALONE SYSTEM

The TPS is a stand alone system that works together with Power Focus, Tensor DL/DS Drive D312/D31, Micro Torque controllers and EBL RE driver. A pneumatic license and air tool package is available to make the TPS work with RE controlled air tools.

OPTIONS

All options are activated by a license code. The license code is ordered separately.

BARCODE READER LICENSE OPTION

Use a barcode reader to start a job and/or identify a job for the TPS to select the correct Pset.

RESULT REPORT FUNCTION OPTION

Save the results to a PC. The results can be saved in two ways, report on job or report on sequence and job.

PNEUMATIC TOOL LICENSE OPTION

The pneumatic tool license also includes the necessary valves and hoses for a correct set up of RE controlled air tools.

TPS Controller

TPS CONTROLLER – CONTROL THE SEQUENCE AND THE POSITION

With a TPS controller you are always sure that the operator tightens the joints in the correct sequence and in the correct position.

- Up to 50 jobs and up to 500 positions.
- OK/NOK signal on position.
- The tool will not start when it is out of position.
- Batch count together with OK/NOK on position.
- Works together with Atlas Copco electric tools and RE controlled pneumatic tools.
- Possibility to save and upload set up through a PC.
- Easy and fast set up and programming.
- Error proofing solution.
- ESD approved.



HOW TO ORDER

1. TPS Controller
2. Select positioning torque arm by style (T-series linear or swivel, or SMC telescopic) and torque arm capacity
3. Cable TPS to tool controller
4. Power supply - optional.
(Order power cord separately)
5. Select other options if applicable

TPS CONTROLLER

| Model | Ordering No. |
|----------------|--------------|
| TPS Controller | 8202 9004 10 |

CONTROLLER ACCESSORY

| Model | Ordering No. |
|-------------------|--------------|
| I/O Extension TPS | 4390 2049 00 |

POWER SUPPLY/CORD

| Model | Ordering No. |
|----------------------------------|--------------|
| Power supply 24VDC 30W | 4222 1728 50 |
| Power cord | |
| EU | 4222 1801 13 |
| US | 4222 1802 13 |
| UK | 4222 1803 13 |
| India | 4222 1804 13 |
| Switzerland | 4222 1805 13 |
| Italy | 4222 1806 13 |
| Australia | 4222 1807 13 |
| China | 4222 1809 13 |

OPTIONS

| Model | Ordering No. |
|-------------------|--------------|
| Barcode license | 4390 2045 00 |
| Pneumatic license | 4390 2046 00 |
| Reporting license | 4390 2047 00 |

CABLES

| Model | Ordering No. |
|---|--------------|
| Cable TPS to controller Power Focus/Tensor | |
| 3 m | 4222 1715 03 |
| 10 m | 4222 1715 10 |
| Cable TPS to controller Power Focus 600 | |
| 3 m | 4222 1852 03 |
| 10 m | 4222 1852 10 |
| Cable TPS to EBL RE driver | |
| 1.5 m | 4222 1733 01 |
| 3 m | 4222 1733 03 |
| Cable TPS to controller G4 | |
| 1.5 m | 4222 1734 01 |
| 3 m | 4222 1734 03 |
| Cable TPS to controller MTF400 | |
| 1.5 m | 4222 1735 01 |
| 3 m | 4222 1735 03 |
| TPS Open End cable | |
| 3 m | 4222 1743 03 |
| 10 m | 4222 1743 10 |

SMC POSI L

SMC carbon arms with 1 encoder to measure the distance the arm travels. With this arm and encoder it is possible to verify the position due to the distance the arm travels. The encoder is mounted inside the arm to safe guard that nothing can interfere with the distance measurements. The SMC POSI L arm can work in both horizontal and vertical position and thus be roof or wall mounted. The accuracy of the encoder is 0.32 mm and the arm together with a TPS controller control the sequence and position.

- Carbon arm with position control up to 200 Nm.
- Encoder measures the distance the arm travels.
- Verify position due to distance.
- Can be mounted both in horizontal and vertical position for maximum flexibility.
- Accuracy of encoder 0.32 mm.
- Control the sequence and position together with TPS controller.

SMC POSI LA

SMC carbon arms with 2 encoders to measure the length the arm travels and the angle of the arm to determine the position of the arm/tool. With this SMC carbon arm it is possible to verify the position due to the length the arm travels together with an encoder that measures the angle of the arm. The length encoder is mounted inside the arm to safe guard that nothing can interfere with the length measurement and the angle encoder is mounted at the top of the arm. The SMC POSI LA can work in both horizontal and vertical position and thus be roof or wall mounted. The accuracy of the encoders is 0.32 mm and the arm together with a TPS controller will control the sequence and position.

- Carbon arm with 2 encoders to control position.
- Encoders measure the arm travel length and the angle of the arm to determine the position.
- Can be mounted both in horizontal and vertical position for maximum flexibility.
- Accuracy of encoder is 0.32 mm.
- Control the sequence and position together with the TPS controller.
- Arms available up to 200 Nm.

SML/SMS T-SERIES POSITIONING ARMS

The Atlas Copco T-series of arms are built to handle the most demanding industrial situation when you need to control the sequence and the position. The T-series arms are equipped with two encoders, SMS T-series have 2 angle encoders to determine the position and



SML T-series have 1 linear encoder and 1 angle encoder to determine the position. The arms are delivered with balancer, encoders and encoder cables ready to be plugged into the TPS controller.

- Control the sequence and position together with TPS controller.
- Excellent working area for work bench assembly stations.
- Available up to 100 Nm.

SMC CARBON ARMS WITH 1 ENCODER

| Model | Ordering No. |
|---------------------|--------------|
| SMC 12 1150 POSI L | 4390 1510 77 |
| SMC 12 1600 POSI L | 4390 1511 87 |
| SMC 12 2100 POSI L | 4390 1512 87 |
| SMC 25 1150 POSI L | 4390 1514 77 |
| SMC 25 1600 POSI L | 4390 1515 87 |
| SMC 25 2100 POSI L | 4390 1516 87 |
| SMC 25 2600 POSI L | 4390 1517 87 |
| SMC 50 1600 POSI L | 4390 1518 77 |
| SMC 50 2100 POSI L | 4390 1519 87 |
| SMC 50 2600 POSI L | 4390 1520 87 |
| SMC 100 1600 POSI L | 4390 1522 87 |
| SMC 100 2100 POSI L | 4390 1523 77 |
| SMC 100 2600 POSI L | 4390 1524 87 |
| SMC 200 1600 POSI L | 4390 1526 87 |
| SMC 200 2100 POSI L | 4390 1527 87 |
| SMC 200 2600 POSI L | 4390 1528 87 |

SMC CARBON ARMS WITH 2 ENCODERS

| Model | Ordering No. |
|----------------------|--------------|
| SMC 12 1150 POSI LA | 4390 1510 79 |
| SMC 12 1600 POSI LA | 4390 1511 79 |
| SMC 12 2100 POSI LA | 4390 1512 79 |
| SMC 25 1150 POSI LA | 4390 1514 79 |
| SMC 25 1600 POSI LA | 4390 1515 79 |
| SMC 25 2100 POSI LA | 4390 1516 79 |
| SMC 25 2600 POSI LA | 4390 1517 79 |
| SMC 50 1600 POSI LA | 4390 1518 79 |
| SMC 50 2100 POSI LA | 4390 1519 79 |
| SMC 50 2600 POSI LA | 4390 1520 79 |
| SMC 100 1600 POSI LA | 4390 1522 79 |
| SMC 100 2100 POSI LA | 4390 1523 79 |
| SMC 100 2600 POSI LA | 4390 1524 79 |
| SMC 200 1600 POSI LA | 4390 1526 79 |
| SMC 200 2100 POSI LA | 4390 1527 79 |
| SMC 200 2600 POSI LA | 4390 1528 79 |

SML / SMS T ARMS WITH 2 ENCODERS

| Model | Ordering No. |
|--------------------|--------------|
| SML T-5 Position | 4390 2030 00 |
| SML T-12 Position | 4390 2031 00 |
| SML T-25 Position | 4390 2032 00 |
| SML T-50 Position | 4390 2034 00 |
| SML T-100 Position | 4390 2035 00 |
| SMS T-5 Position | 4390 2036 00 |
| SMS T-12 Position | 4390 2037 00 |
| SMS T-25 Position | 4390 2038 00 |
| SMS T-50 Position | 4390 2039 00 |
| SMS T-100 Position | 4390 2040 00 |

NOTE: Tool holder needs to be ordered separately. SML/SMS T-series are equipped with balancer.

Choose the appropriate balancer for SMC arms depending on tool weight and order the balancer kit for easy and fast assembly if the arm is roof mounted.

SMLT – SERIES TORQUE ARMS

The Atlas Copco linear arms are built to handle the most demanding industrial situations. The robust design offers unmatched user friendliness. The linear arms are equipped with ball bearings for smooth operation, and an adjustable plate for maximum adjustment of minimum and maximum working area. The linear arms have balancer included that will absorb the weight of the arm and tool combination to reduce the weight for the operator. The arms minimize the reaction force of the tool to prevent hand-arm-shoulder disorders. With minimized reaction force of the tool, finished product quality is also higher since there is no movement of the tool and all torque is absorbed in the joint.

- Robust construction for long life and no force transferred to operator.
- Balancer included to remove the tool and arm weight from the operator.
- Available from 5 Nm up to 100 Nm.
- Minimizes reaction force to prevent hand-arm-shoulder disorders.
- Improves finished product quality with all torque absorbed in the joint and no movement of tool.



| Model | Max tool weight | | Max torque | | Min width without tool holder in | A Max reach without tool holder in | B Horizontal stroke in | Vertical stroke in | C Height in | Tool holder interface type | Ordering No. |
|-----------|-----------------|------|------------|-------|-------------------------------------|--|------------------------------|-----------------------|-------------------|----------------------------|--------------|
| | kg | lb | Nm | ft lb | | | | | | | |
| SML T-5 | 0.8 | 1.7 | 5 | 3.7 | 6.2 | 20.9 | 8.1 | 12.2 | 28.8 | A | 4390 2000 00 |
| SML T-12 | 1.5 | 3.3 | 12 | 8.8 | 7.8 | 25.5 | 10.0 | 18.3 | 35.0 | A | 4390 2001 00 |
| SML T-25 | 2.2 | 4.8 | 25 | 18.4 | 6.6 | 28.8 | 11.4 | 24.2 | 43.3 | A | 4390 2002 00 |
| SML T-50 | 5 | 11 | 50 | 36.9 | 10.5 | 34.9 | 14.0 | 20.3 | 43.9 | B | 4390 2004 00 |
| SML T-100 | 6 | 13.2 | 100 | 73.8 | 10.0 | 36.0 | 15.6 | 20.3 | 43.9 | B | 4390 2005 00 |

Tool holder is ordered separately.

Dimensions

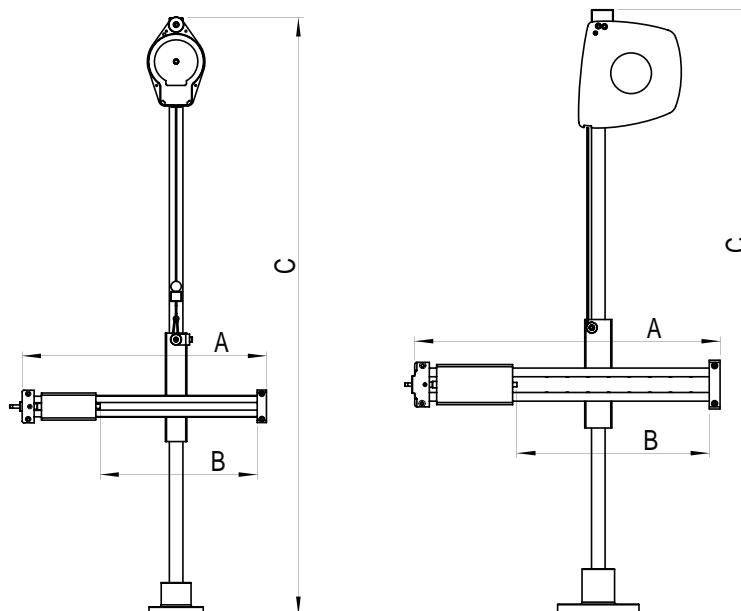

SMST – SERIES TORQUE ARMS

The Atlas Copco linear arms are built to handle the most demanding industrial situations. The robust design offers unmatched user friendliness and, due to the swivel function, a wide working area is covered with the SMS T-series. The swivel arms are equipped with ball bearings for smooth operation, and an adjustable plate for maximum adjustment of minimum and maximum working area. The swivel arms have a balancer included that will absorb the weight of the arm and tool combination to reduce the weight for the operator. The arms minimize reaction force of the tool to prevent hand-arm-shoulder disorders. With minimized reaction force of the tool, finished product quality is also higher since there is no movement of the tool and all torque is absorbed in the joint.

- Robust construction for long life and no force transferred to operator.
- Balancer included to remove the tool and arm weight from the operator.
- Available from 5 Nm up to 100 Nm.
- Minimizes reaction force to prevent hand-arm-shoulder disorders.
- Improves finished product quality with all torque absorbed in the joint and no movement of the tool.



| Model | Max tool weight | | Max torque | | D | B+D | C | A | B | Tool holder interface type | Ordering No. |
|-----------|-----------------|------|------------|-------|--|----------------------------------|--------------------|-----------|----------|----------------------------|--------------|
| | kg | lb | Nm | ft lb | Swivel rods width without tool holder in | Max reach without tool holder in | Vertical stroke in | Height in | Width in | | |
| SMS T-5 | 0.8 | 1.7 | 5 | 3.7 | 11.5 | 22.9 | 10.6 | 28.8 | 9.8 | A | 4390 2006 00 |
| SMS T-12 | 1.5 | 3.3 | 12 | 8.8 | 13.5 | 26.9 | 16.7 | 35.0 | 11.7 | A | 4390 2007 00 |
| SMS T-25 | 2.5 | 5.5 | 25 | 18.4 | 15.4 | 28.8 | 22.8 | 44.6 | 11.7 | A | 4390 2008 00 |
| SMS T-50 | 5 | 11 | 50 | 36.9 | 17.2 | 32.5 | 20.5 | 45.2 | 13.2 | B | 4390 2009 00 |
| SMS T-100 | 6 | 13.2 | 100 | 73.8 | 19.2 | 36.6 | 19.7 | 45.2 | 15.4 | B | 4390 2010 00 |

Tool holder is ordered separately.

Dimensions

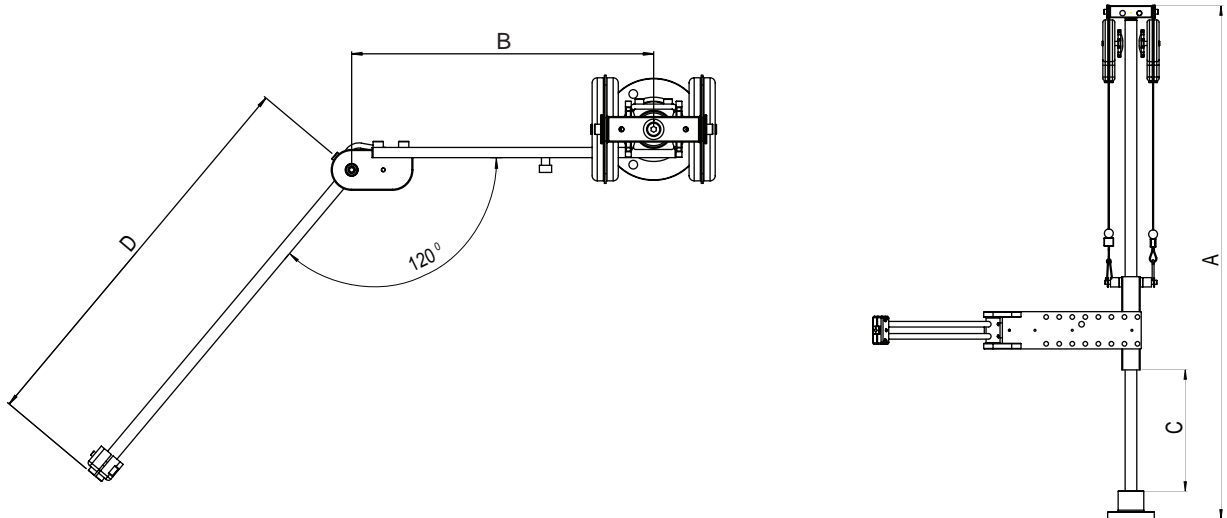

SMC – CARBON ARMS

The Atlas Copco carbon arms have a telescopic design for maximum flexibility in the workplace. The carbon arms are light weight with smooth movements to reduce the operator force to use the arms. Together with a balancer the carbon arms can either retract up or be used in a weightless position to improve operator comfort. The carbon arms minimize reaction force to prevent hand-arm-shoulder disorders. With minimized reaction force of the tool you will also improve finished product quality because there is no movement of the tool and all torque is absorbed in the joint.

- Telescopic design for maximum flexibility in the workplace.
- Light weight and smooth movements for operator comfort.
- Easy to use together with balancer to create weightless solution to improve ergonomics.
- Minimizes reaction force to prevent hand-arm-shoulder disorders.
- Minimizes pinching and can replace reaction bars.
- Improve finished product quality with all torque absorbed in the joint and no movement of the tool.



| Model | Max torque | | Min length in | Max length in | A Max tool holder swivel angle [deg] | Weight | | Tool holder interface type | Ordering No. |
|--------------|------------|-------|------------------|------------------|---|--------|-------|----------------------------------|--------------|
| | Nm | ft lb | | | | kg | lb | | |
| SMC 12 1150 | 12 | 8.9 | 20.3 | 44.4 | 60 | 0.37 | 0.816 | A | 4390 1510 85 |
| SMC 12 1600 | 12 | 8.9 | 26.2 | 62.1 | 60 | 0.42 | 0.926 | A | 4390 1511 85 |
| SMC 12 2100 | 12 | 8.9 | 32.9 | 82 | 60 | 0.48 | 1.06 | A | 4390 1512 85 |
| SMC 25 1150 | 25 | 18.4 | 20.6 | 44.3 | 50 | 0.51 | 1.12 | A | 4390 1514 85 |
| SMC 25 1600 | 25 | 18.4 | 26.5 | 62 | 50 | 0.61 | 1.34 | A | 4390 1515 85 |
| SMC 25 2100 | 25 | 18.4 | 33.1 | 81.7 | 50 | 0.68 | 1.5 | A | 4390 1516 85 |
| SMC 25 2600 | 25 | 18.4 | 39.6 | 101.3 | 50 | 0.77 | 1.7 | A | 4390 1517 85 |
| SMC 50 1600 | 50 | 36.9 | 28 | 63.9 | 40 | 0.95 | 2.09 | B | 4390 1518 85 |
| SMC 50 2100 | 50 | 36.9 | 34.6 | 83.7 | 40 | 1.05 | 2.31 | B | 4390 1519 85 |
| SMC 50 2600 | 50 | 36.9 | 41.1 | 103.4 | 40 | 1.15 | 2.54 | B | 4390 1520 85 |
| SMC 100 1600 | 100 | 73.8 | 28.4 | 64.1 | 30 | 1.28 | 2.82 | B | 4390 1522 85 |
| SMC 100 2100 | 100 | 73.8 | 35 | 83.8 | 30 | 1.41 | 3.11 | B | 4390 1523 85 |
| SMC 100 2600 | 100 | 73.8 | 41.6 | 103.5 | 30 | 1.53 | 3.37 | B | 4390 1524 85 |
| SMC 200 1600 | 200 | 148 | 28.6 | 64.1 | 20 | 1.98 | 4.37 | - | 4390 1526 85 |
| SMC 200 2100 | 200 | 148 | 35.2 | 83.8 | 20 | 2.18 | 4.81 | - | 4390 1527 85 |
| SMC 200 2600 | 200 | 148 | 41.7 | 103.5 | 20 | 2.39 | 5.27 | - | 4390 1528 85 |
| SMC 300 1600 | 300 | 221 | 29.3 | 64.2 | 20 | 2.40 | 5.29 | - | 4390 1530 85 |
| SMC 300 2100 | 300 | 221 | 35.9 | 83.9 | 20 | 2.60 | 5.73 | - | 4390 1531 85 |
| SMC 300 2600 | 300 | 221 | 42.4 | 106.7 | 20 | 2.81 | 6.20 | - | 4390 1532 85 |

Tool holder is ordered separately. Choose the appropriate balancer depending on tool weight. Order the balancer kit for easy and fast assembly.
NOTE: A: 17 mm square interface, B: 32 mm square interface. For SMC 200 the tool holders connect directly to the clevis of the arm.

Dimensions

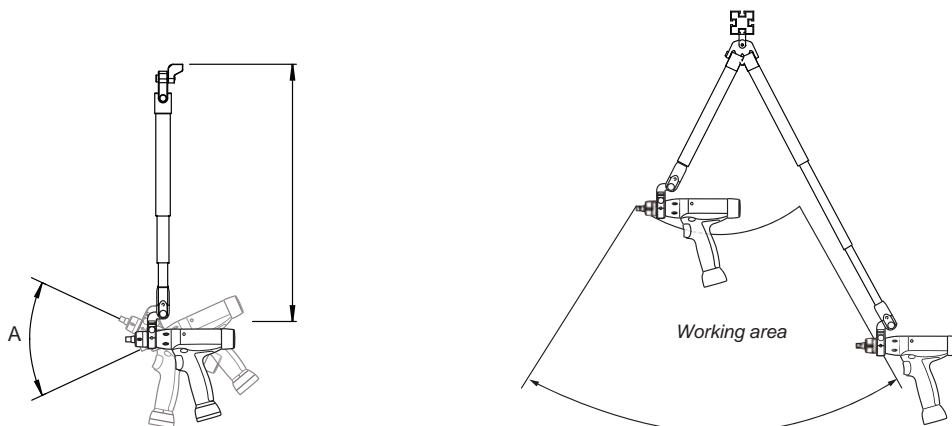

TORQUE ARM SML MK II

By mounting your assembly tool on a SML MK II torque arm you will immediately increase the productivity and reduce muscular stress from your operators. All arms are delivered with integrated balancer, 3-axis movement and the Atlas Copco interface for tool holders. The 3-axis movement allows the operator to ease the arm effortlessly around the workstation.

- 3-axis movement for maximum flexibility.
- Strong and durable desing.
- Integrated balancer to support tool and arm weight.
- High torque capacity, up to 1000 Nm.
- Same tool holder interface as SML T / SMS T / SMC for arms up to 150 Nm.



| Model | Max tool weight | | Max torque | | D | | A | Tool holder interface type | Ordering No. |
|----------------|-----------------|------|------------|-------|-------------------|-----------------|------|----------------------------|--------------|
| | kg | lb | Nm | ft lb | Horizontal stroke | Vertical stroke | | | |
| SML 10 MK II | 1 | 2.2 | 10 | 7.4 | 9.4 | 8.7 | 26.8 | A | 8202 9003 20 |
| SML 40 MK II | 2.3 | 5.1 | 40 | 29.5 | 11.0 | 11.4 | 32.8 | B | 8202 9003 21 |
| SML 80 MK II | 5.2 | 11.5 | 80 | 59 | 12.6 | 14.2 | 38 | B | 8202 9003 22 |
| SML 150 MK II | 7 | 15.4 | 150 | 110.7 | 14.2 | 16.9 | 41.3 | C | 8202 9003 23 |
| SML 300 MK II | 14 | 30.9 | 300 | 221.4 | 15.7 | 19.7 | 48.5 | C | 8202 9003 24 |
| SML 500 MK II | 10 | 22 | 500 | 369 | 17.3 | 22.4 | 53.6 | C | 8202 9003 25 |
| SML 1000 MK II | 11.3 | 24.9 | 1000 | 738 | 18.9 | 25.2 | 61.9 | C | 8202 9003 26 |

Tool holder is ordered separately.

Dimensions

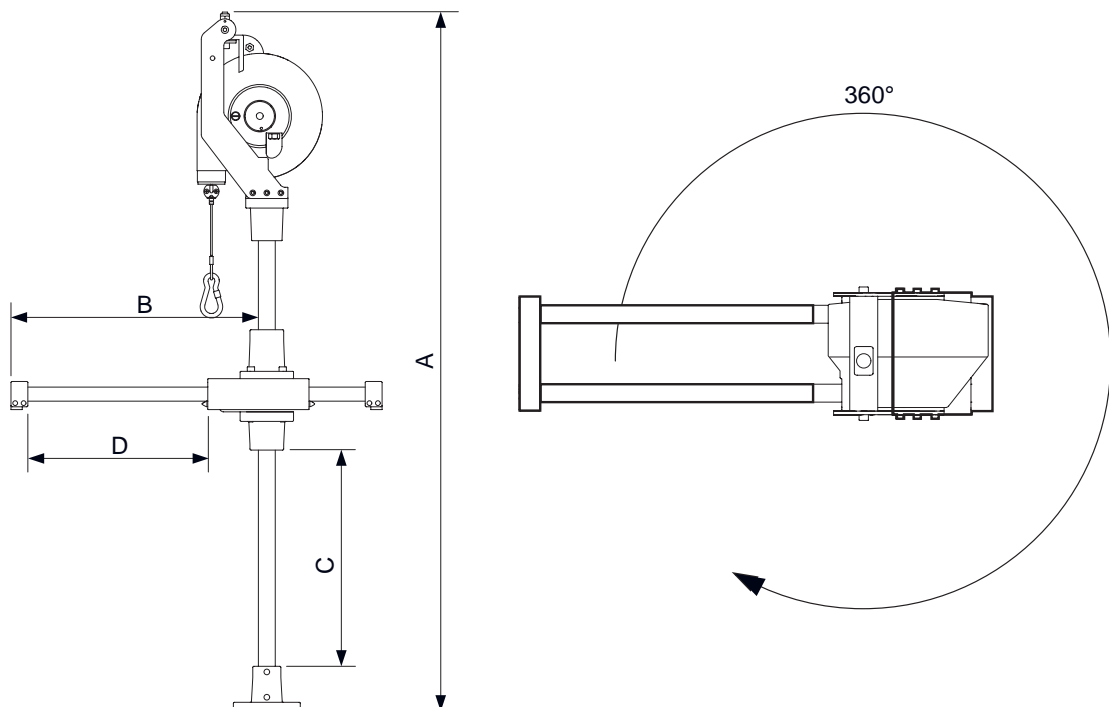

GHP – TORQUE ARM FOR MICROTORQUE RANGE

Atlas Copco GHP torque arm is an excellent means of assistance when using hand-held or fixtured straight MicroTorque screwdrivers.

Torque arm GHP Mini is recommended with screwdrivers below 100 Ncm, and GHP Small below 200 Ncm.

The GHP torque arms are exceptionally easy to position and handle. The design is intended for low torque applications and work tasks over a long period of time. Comes with appropriate balancing system to support the weight of the tool.



| Model | Stroke | | Ordering No. |
|-----------|--------|------|--------------|
| | in | alfa | |
| GHP Mini | 7.9 | 270° | 8432 0830 02 |
| GHP Small | 15.7 | 270° | 8432 0830 03 |
| GHP Large | 28.7 | 270° | 8432 0830 04 |

Tool holder is ordered separately.

Dimensions

| Model | Working range, in | |
|-----------|-------------------|-----|
| | A | B |
| GHP Mini | 11.0 | 5.9 |
| GHP Small | 18.1 | 9.8 |
| GHP Large | 19.7 | 9.8 |

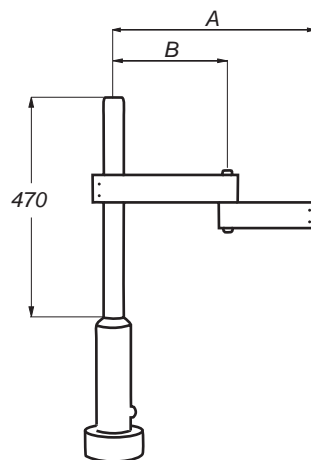

GHP Mini

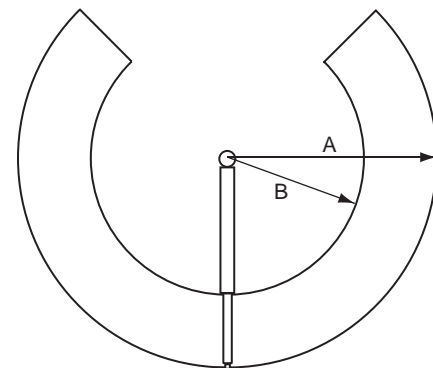

GHP Small/GHP Large

Optional Accessories

TOOL HOLDER GUIDE

Atlas Copco tool holders are designed to optimize your workplace solution. Depending on tool, torque arm and application you can choose from a wide range of tool holders; universal holder, specific diameter holders, spline holders, mounting plates with spine or hole, pistol tool holders or angle tool holders. A tool specific tool holder is always better than a universal holder.

HOW TO BUILD YOUR WORKPLACE SOLUTION

- 1) Tool
- 2) Torque arm
 - Torque range
 - Work area
 - Tool weight
- 3) Tool holder
 - Arm - Tool holder interface type (or mounting on arm clevis, as for SMC angle tool holders)
 - Tool interface: eg. Spline, Diameter or Angle
- 4) Accessories
- 5) For SMC - Balancer

TOOL HOLDERS FOR TORQUE ARMS WITH TOOL HOLDER INTERFACE TYPE A SMC 12/25 AND SMS/LT 5/12/25 AND SML MK II 10

| Model | Tool dia. mm | Spline type | Arm interface | | Description | Ordering No. |
|--|-----------------|----------------|------------------|------|-------------------------|--------------|
| | | | type | type | | |
| Universal holder | 26 - 49 | - | - | A | Max tool torque 25 Nm | 4390 1510 86 |
| Holder, Spline 1 | - | 1 | - | A | | 4390 1513 07 |
| Holder, diameter 30.5 | 30 - 30.5 | - | - | A | | 4390 1513 80 |
| Holder, diameter 34 | 33.5 - 34 | - | - | A | | 4390 1513 81 |
| Holder diameter 36.5 | 36 - 36.5 | - | - | A | | 4390 1513 82 |
| Holder diameter 38 | 37.5 - 38 | - | - | A | | 4390 1513 83 |
| Holder diameter 44 | 43.5 - 44 | - | - | A | | 4390 1513 84 |
| Holder diameter 46 | 45.5 - 46 | - | - | A | To be used with adapter | 4390 1513 85 |
| Special adapters to be used with dia 46 mm tool holder | | | | | | |
| | | | | | LUM10 PR | 4390 1734 09 |
| | | | | | LUM21 PR-P | 4390 1735 44 |
| | | | | | LUM12 SR | 4390 1735 52 |
| | | | | | LUM12 PR | 4390 1735 53 |
| | | | | | LUM22 PR | 4390 1735 54 |
| Holder diameter 56 | 55.5-56 | - | - | A | To be used with adapter | 4390 1513 86 |
| Special adapters to be used with dia 56 mm tool holder | | | | | | |
| | | | | | LUM21 SR | 4390 1735 45 |
| | | | | | LUM22 SR | 4390 1735 51 |
| Mounting plate, Spline 1 | - | 1 | - | A | | 4390 2020 00 |
| Mounting plate, Spline 2 | - | 2 | - | A | | 4390 2020 01 |
| Mounting plate, hole 24 | 24 | - | - | A | | 4390 2020 02 |
| Mounting plate, hole 26 | 26 | - | - | A | | 4390 2020 03 |
| Mounting plate, hole 28 | 28 | - | - | A | | 4390 2020 04 |
| Mounting plate, blank | - | - | - | A | | 4390 2020 05 |



Universal tool holder



Tool holder, diameter

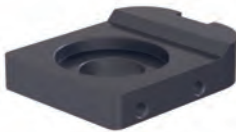

Mounting plate



Tool holder, Spline

TOOL HOLDERS FOR TORQUE ARMS WITH TOOL HOLDER INTERFACE TYPE B, SMC 50/100 AND SMS/LT 50/100 AND SML MK II 40/80

| Model | Tool dia. mm | Spline type | Arm interface | | Description | Ordering No. |
|--------------------------|-----------------|----------------|------------------|------|-----------------------|--------------|
| | | | type | type | | |
| Universal holder | 30 - 50 | - | - | B | Max tool torque 50 Nm | 4390 2064 80 |
| Holder, Spline 1 | - | 1 | - | B | | 4390 1513 08 |
| Holder, Spline 2 | - | 2 | - | B | | 4390 1513 09 |
| Holder, Spline 3 | - | 3 | - | B | | 4390 1513 10 |
| Holder, hole 24 | 24 | - | - | B | | 4390 1518 22 |
| Mounting plate, Spline 1 | - | 1 | - | B | | 4390 2021 00 |
| Mounting plate, Spline 2 | - | 2 | - | B | | 4390 2021 01 |
| Mounting plate, Spline 3 | - | 3 | - | B | | 4390 2021 02 |
| Mounting plate, hole 24 | 24 | - | - | B | | 4390 2021 03 |
| Mounting plate, hole 26 | 26 | - | - | B | | 4390 2021 04 |
| Mounting plate, hole 28 | 28 | - | - | B | | 4390 2021 05 |
| Mounting plate, blank | - | - | - | B | | 4390 2021 06 |

Torque Arm Accessories

Optional Accessories

MOUNTING PLATES FOR SML MK II 150/300/500/1000 TORQUE ARMS, TOOL HOLDER INTERFACETYPE C

| Model | Tool dia. mm | Spline type | Arm interface type | Description | Ordering No. |
|-----------------------------|-----------------|----------------|--------------------------|-------------|--------------|
| Mounting plate, Spline 1 | - | 1 | C | | 4390 1760 00 |
| Mounting plate, Spline 2 | - | 2 | C | | 4390 1761 00 |
| Mounting plate, Spline 3 | - | 3 | C | | 4390 1762 00 |
| Mounting plate, Spline 4 | - | 4 | C | | 4390 1763 00 |
| Mounting plate, Spline 5 | - | 5 | C | | 4390 1764 00 |
| Mounting plate, Spline 6 | - | 6 | C | | 4390 1765 00 |
| Mounting plate, Spline 7 | - | 7 | C | | 4390 1766 00 |
| Mounting plate, QMX/ETX50 | - | - | C | | 4390 1782 00 |
| Mounting plate, QMX/ETX62 | - | - | C | | 4390 1783 00 |
| Mounting plate, QMX90/ETX90 | - | - | C | | 4390 1785 00 |
| Extension mounting plate | - | - | C | | 4390 1768 00 |

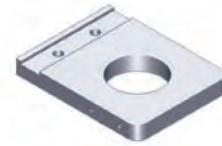

Mounting plate



Extension mounting plate

PISTOL TOOL HOLDERS FOR SMC CARBON ARMS

| Model | Tool dia. mm | Spline type | Arm interface type | Description | Ordering No. |
|-------------------------|-----------------|----------------|--------------------------|-------------|--------------|
| Pistol holder, hole 24 | 24 | - | - | For SMC 50 | 4390 1518 18 |
| Pistol holder, Spline 2 | - | 2 | - | For SMC 100 | 4390 1522 18 |
| Pistol holder, Spline 2 | - | 2 | - | For SMC 200 | 4390 1526 18 |
| Pistol holder, Spline 3 | - | 3 | - | For SMC 200 | 4390 1513 11 |

Tool holder connects directly to the clevis of the arm.



Pistol holder

ANGLE TOOL HOLDERS FOR SMC CARBON ARMS, SMC 50

| Model | Description | Ordering No. |
|-----------------------|---|--------------|
| Angle tool holder for | LTV38-R50-13, LTV38-R42-13 | 4390 2062 80 |
| | LTV38-R50-HAD, LTV38-R42-HAD | 4390 2062 81 |
| | LTV38-R50-10, LTV38-R42-10 | 4390 2062 82 |
| | LTV39-2 R30-10, LTV39-2 R37-10, LTV39-2 R48-10 | 4390 2062 83 |
| | ETV ST61-40-10, ETV ST61-40-HAD, ETV STB62-40-10, ETV STB62-50-10 | 4390 2062 84 |
| | ETV STB32-30-10, ETV ST61-30-10, ETV STB62-30-10 | 4390 2062 85 |
| | LTV39-2 R48-13 | 4390 2062 86 |
| | LTV29-2 R30-10 | 4390 2062 87 |
| | ETV S72-30-10, ETV S42-30-10 | 4390 2062 88 |
| | ETV S72-40-10 | 4390 2062 89 |
| | ETV DS72-40-10 | 4390 2062 90 |

Tool holder connects directly to the clevis of the arm.

NOTE: 4390 2062 88 is attached to the arm by the arm tool holder interface B.



Angle tool holder

ANGLE TOOL HOLDERS FOR SMC CARBON ARMS, SMC 100

| Model | Description | Ordering No. |
|-------------------|--|--------------|
| Angle tool holder | ETV ST81-100-13, ETV ST61-100-13, ETV STB62-100-13 | 4390 2061 80 |
| | ETV DS72-70-HAD | 4390 2061 81 |
| | ETV STB62-70-13, ETV ST81-70-13-L150, ETV ST81-70-13, ETV ST61-70-13, ETV ST81-90-HAD, ETV ST61-90-HAD | 4390 2061 82 |
| | ETV S72-50-10/B10, LTV39-2 R70-13, LTV39-2 R56-13, ETV S7-50-10 | 4390 2061 83 |
| | LTV39-2 R85-13 | 4390 2061 84 |
| | LTV38-R85-13 | 4390 2061 85 |
| | LTV38 R85-HAD | 4390 2061 86 |
| | ETV ST81-50-10, ETV ST61-50-HAD, ETV ST61-50-10, LTV39-2 R56-10 | 4390 2061 87 |
| | ETV ST101-100-HAD, ETV ST101-100-13, ETV ST101-100-INTEL, ETV S72-100-13 | 4390 2061 88 |
| | LTV38 R70-13 | 4390 2061 89 |
| | LTV38 R57-13 | 4390 2061 90 |
| | ETV DS72-70-13 | 4390 2061 91 |
| | ETV DS92-100-13 | 4390 2061 92 |
| | ETV S72-70-13 | 4390 2061 93 |
| | ETV DS72-50-HAD, ETV DS72-50-10 | 4390 2061 94 |

Tool holder connects directly to the clevis of the arm.



Angle tool holder

Optional Accessories

Bench stand



ANGLE TOOL HOLDERS FOR SMC CARBON ARMS, SMC 200

| Model | Description | Ordering No. |
|-------------------|--|--------------|
| Angle tool holder | ETV ST61-200, ETV ST81-200 | 4390 1513 87 |
| | ETV ST101-180-13 / 13-F / 13-M / 13-M-F, ETV ST101-180-B13 / B13-F, ETV S72-150-13 / B13, ETV S72-180-13 / B13, ETV S92-180-13 | 4390 2060 80 |
| | ETV ST61-150-13 / B13 / 13-ATEX, ETV ST61-180-13 / B13 / 13-ATEX, ETV ST81-150-13 / B13, ETV ST81-180-13 / B13 | 4390 2060 81 |
| | ETV DS92-180-13 | 4390 2060 82 |
| | ETV DS72-160-13 / B13, ETV DS72-180-13 / B13 | 4390 2060 83 |
| | LTV48 R120-L13 / R150-L13 / R200-L13 | 4390 2060 84 |
| | LTV69 R180-13, LTV69 N180-13 | 4390 2060 85 |
| | LTV48 R120-HAD / R150-HAD / R200-HAD LTV48 R120-FS / R150-FS / R200-FS | 4390 2060 86 |
| | ETV ST61-150-FS / 180-FS ETV ST61-120-HAD / 150-HAD / 180-HAD ETV ST81-120-HAD / 150-HAD / 180-HAD ETV ST81-150-FS / 180-FS | 4390 2060 87 |
| | ETV ST101-180-FS / FS-F, ETV ST101-180-Intel / Intel-F ETV ST101-180-HAD / HAD-F | 4390 2060 88 |
| | ETV DS72-160-FS, ETV DS72-100-HAD / 160-HAD | 4390 2060 89 |
| | ETV DS72-100-13 / B13 | 4390 2060 90 |

Tool holder connects directly to the clevis of the arm.

Holder for bench stand



TOOL HOLDERS FOR SMC CARBON ARMS, SMC 300

| Model | Description | Ordering No. |
|--------------------|----------------------------------|--------------|
| Angle tool holder | ETV ST101-270 | 4390 2081 50 |
| Pistol tool holder | ETP ST101-300-20-F (Tensor Rev0) | 4391 2081 51 |

OPTIONAL ACCESSORIES FOR SMC CARBON ARMS

| Model | Description | Ordering No. |
|------------------------|--|------------------------------|
| Bench stand | Bench stand with height 753 mm. Holder must be ordered separately | 4390 1728 00 |
| Holder for bench stand | Stand attachment 12-25 Nm Stand attachment 50-100 Nm SMC 200 should not be used with table stand | 4390 1510 88 4390 1518 88 |
| Balancer kit | SMC Balancer adaptor kit for RIL 1C-5C and WP10 SMC Balancer adaptor kit for WP05 | 4390 2050 00 4390 2078 80 |

Horizontal adapter



OPTIONAL ACCESSORIES FOR SML/SMS T-SERIES AND SML MK II

| Description | Ordering No. |
|---|--|
| Horizontal adapter (handle mount) | 4390 1770 00 |
| Vertical adapter (handle mount) | 4390 1769 00 |
| Start handle | (electric, 1 signal) 4390 1772 00 (electric, 2 signal) 4390 1773 00 (pneumatic) 4390 1771 00 |
| Heavy duty start handles | (electric, 1 signal) 4390 1772 01 (electric, 2 signal) 4390 1773 01 (pneumatic) 4390 1771 01 |
| Heavy duty handgrip (dead) | 4390 1786 01 |
| Handgrip (dead handle) | 4390 1786 00 |
| Remote start cable | 3 m 4390 1774 00 5 m 4390 1775 00 10 m 4390 1776 00 |
| Extension remote start cable | 10 m 4390 1778 00 |
| Y- piece connector (for 2 x electric handles) | 4390 1777 00 |

Vertical adapter



Start handle



NOTE: – For forward and reverse tool operation, a 2 signal handle is required (electric tools only).

Torque Arm Accessories

Installation Proposals for SML

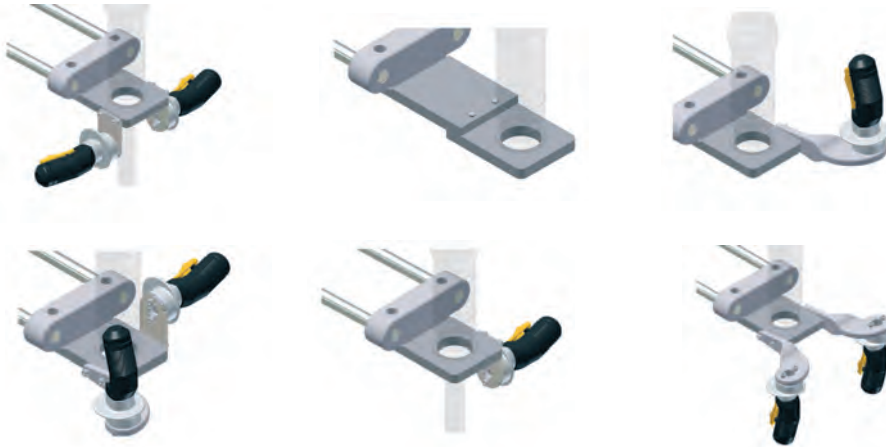

Optional Accessories for GHP MicroTorque

| Description | Ordering No. |
|--|--------------|
| Adapter | |
| Adapter between GHP Mini and ETF 5, 10, 20 | 8432 0830 70 |
| Adapter between GHP Mini and ETD M 03/05/10A | 8432 0831 81 |
| Adapter between GHP Small and ETF 50-200 | 8432 0830 72 |
| Adapter between GHP Small and ETD M-40-250 L | 8432 0830 73 |
| Adapter between GHP Large and ETF 400, 500, 800 | 8432 0830 74 |
| Universal adapter for GHP Small (LUM, EBL, DL, SL) | 8432 0831 80 |
| Handle | |
| Handle between GHP Mini and ETF 05, 10, 20 | 8432 0830 90 |
| Handle between GHP Small and ETF 50, 100, 200 | 8432 0830 53 |
| Handle between GHP Large and ETF 400, 500, 800 | 8432 0830 54 |
| Swivling tool holder | |
| GHP Small and ETD M08-27 ABL V2 | 8432 0830 61 |
| GHP Small and ETD M50-250 ABL V2 | 8432 0830 62 |



Swivling tool holder



Tool holster small



Tool holster large

Optional Accessories

TOOL HOLSTER FOR PISTOL GRIP AND STRAIGHT TOOLS

| Model | Ordering No. |
|---|--------------|
| Tool holster small, max tool width 45 mm | 4220 3584 82 |
| Tool holster large , max tool width 98 mm | 4220 3584 84 |
| Holster assembly | 4220 3584 80 |
| Tool holster BCP | 4220 3535 80 |

MODULAR TOOL HOLDER FOR PISTOL TOOLS, ANGLE TOOLS AND GRINDERS

| Model | Included parts | Ordering No. |
|--------------------------------|----------------|--------------|
| Modular tool holder | A | 4220 3584 83 |
| Modular tool holder, rail kit | 2 X A, B | 4220 3584 84 |
| Modular tool holder, stand kit | 2 X A, B, C | 4220 3584 85 |

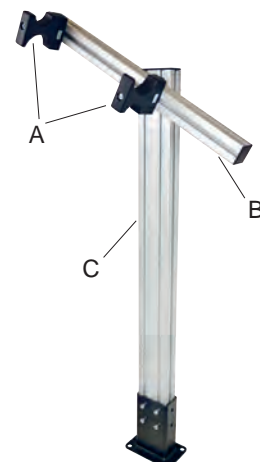

Modular tool holder

Screwdriver Bits – Hexagon Drive

DRIVE SYSTEM: 1/4" HEXAGON, STYLE C 6.3

SCREW PROFILE:



SLOTTED BITS

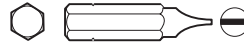

Application: For slotted screws
Drive: 1/4" Hexagon, Style C 6.3

| Blade thickness mm | Blade width mm | Length mm | Ordering No. |
|--------------------|----------------|-----------|--------------|
| 0.55 | 3.5 | 25 | 4023 1400 21 |
| 0.6 | 4 | 25 | 4023 1400 22 |
| 0.8 | 5.5 | 25 | 4023 1400 26 |

PHILLIPS BITS



Application: For Phillips screws
Drive: 1/4" Hexagon, Style C 6.3

| Point | Length mm | Ordering No. |
|-------|-----------|--------------|
| PH0 | 25 | 4023 1326 00 |
| PH1 | 25 | 4023 0696 01 |
| PH2 | 25 | 4023 0697 01 |
| PH3 | 25 | 4023 0698 01 |

HEX BITS

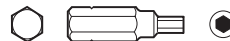

Application: For Hex-socket screws
Drive: 1/4" Hexagon, Style C 6.3

| Point | Length mm | Ordering No. |
|-------|-----------|--------------|
| 2 | 25 | 4023 1318 00 |
| 2.5 | 25 | 4023 1319 00 |
| 3 | 25 | 4023 0819 00 |
| 4 | 25 | 4023 1320 00 |
| 5 | 25 | 4023 0820 00 |
| 6 | 25 | 4023 0821 00 |
| 7 | 25 | 4023 1430 00 |
| 8 | 25 | 4023 0905 00 |

TORXPLUS BITS

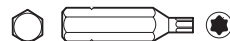

Application: For TorxPlus screws
Drive: 1/4" Hexagon, Style C 6.3

| Point | Length mm | Ordering No. |
|-------|-----------|--------------|
| IP6 | 25 | 4023 0001 70 |
| IP8 | 25 | 4023 0001 74 |
| IP10 | 25 | 4023 0001 78 |

TORX BITS

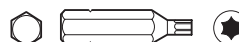

Application: For Torx screws
Drive: 1/4" Hexagon, Style C 6.3

| Point | Length mm | Ordering No. |
|-------|-----------|--------------|
| TX6 | 25 | 4023 0001 60 |
| TX8 | 25 | 4023 1329 00 |
| TX9 | 25 | 4023 1330 00 |
| TX10 | 25 | 4023 1321 00 |
| TX15 | 25 | 4023 1331 00 |
| TX20 | 25 | 4023 1322 00 |
| TX25 | 25 | 4023 1332 00 |
| TX27 | 25 | 4023 1333 00 |
| TX30 | 25 | 4023 1323 00 |
| TX40 | 25 | 4023 1334 00 |

POZIDRIV BITS



Application: For Pozidriv screws
Drive: 1/4" Hexagon, Style C 6.3

| Point | Length mm | Ordering No. |
|-------|-----------|--------------|
| PZ1 | 25 | 4023 1101 11 |
| PZ2 | 25 | 4023 1101 12 |
| PZ3 | 25 | 4023 1101 13 |

DRIVE SYSTEM: 5/16" HEXAGON, STYLE C 8

SCREW PROFILE:



HEX BITS

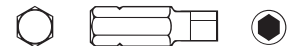

Application: For Hex-socket screws
Drive: 5/16" Hexagon, Style C 8

| Point mm | Length mm | Ordering No. |
|----------|-----------|--------------|
| 5 | 34 | 4023 1215 00 |
| 6 | 25 | 4023 1216 00 |
| 7 | 25 | 4023 1219 00 |
| 8 | 25 | 4023 1217 00 |
| 10 | 25 | 4023 1218 00 |

DRIVE SYSTEM: 3 MM HEXAGON

SCREW PROFILE:



SLOTTED BITS

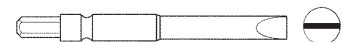

Application: For slotted screws
Drive: 3 mm Hexagon

| Blade thickness mm | Blade width mm | Length mm | Ordering No. |
|--------------------|----------------|-----------|--------------|
| 0.3 | 1.8 | 50 | 4023 0004 03 |
| 0.4 | 2 | 50 | 4023 0004 04 |
| 0.4 | 2.5 | 50 | 4023 0004 05 |
| 0.5 | 3 | 50 | 4023 0004 06 |
| 0.5 | 4 | 50 | 4023 0004 07 |
| 0.5 | 3.5 | 50 | 4023 0004 08 |
| 0.5 | 4.5 | 50 | 4023 0004 09 |
| 0.8 | 4 | 50 | 4023 0004 10 |
| 0.8 | 5.5 | 50 | 4023 0004 11 |

PHILLIPS BITS

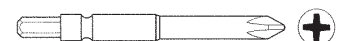

Application: For Phillips screws
Drive: 3 mm Hexagon

| Point | Length mm | Ordering No. |
|-------|-----------|--------------|
| 00 | 50 | 4023 0004 00 |
| 0 | 50 | 4023 0004 01 |
| 1 | 50 | 4023 0004 02 |

Bits and Sockets

TORX BITS

Application: For Torx screws
Drive: 3 mm Hexagon

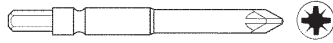

| Point | Length mm | Ordering No. |
|-------|-----------|--------------|
| T6 | 50 | 4023 0004 14 |
| T7 | 50 | 4023 0004 15 |
| T8 | 50 | 4023 0004 16 |
| T10 | 50 | 4023 0004 17 |

POZIDRIV BITS

Application: For Pozidriv screws
Drive: 3 mm Hexagon

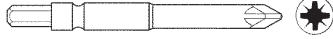

| Point | Length mm | Ordering No. |
|-------|-----------|--------------|
| PZ0 | 50 | 4023 0004 12 |
| PZ1 | 50 | 4023 0004 13 |

DRIVE SYSTEM: 1/4" HEXAGON, STYLE E 6.3

SCREW PROFILE:



SLOTTED BITS

Application: For slotted screws
Drive: 1/4" Hexagon, Style E 6.3



| Blade thickness mm | Blade width mm | Length mm | Ordering No. |
|--------------------|----------------|-----------|--------------|
| 3.2 | 0.7 | 49 | 4023 2020 21 |
| 3.9 | 0.8 | 49 | 4023 2020 23 |
| 4.7 | 0.9 | 49 | 4023 2020 24 |
| 6.3 | 1 | 49 | 4023 2020 26 |
| 7 | 1.1 | 49 | 4023 2020 27 |
| 7.9 | 1.2 | 49 | 4023 2020 28 |
| 9.1 | 1.3 | 49 | 4023 2020 29 |
| 3.2 | 0.7 | 76 | 4023 2030 21 |
| 3.9 | 0.8 | 76 | 4023 2030 23 |
| 4.7 | 0.9 | 76 | 4023 2030 24 |

SLOTTED BITS WITH FINDER

Application: For slotted screws
Drive: 1/4" Hexagon, Style E 6.3

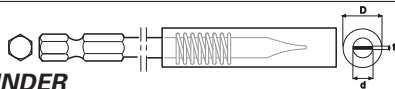

| Outside dia (D) mm | Blade thickness (t) mm | Blade width (d) mm | Length mm | Ordering No. |
|--------------------|------------------------|--------------------|-----------|--------------|
| 9.5 | 0.9 | 4.9 | 95 | 4023 0683 00 |
| 11.1 | 1 | 6.1 | 93 | 4023 1313 00 |
| 12.7 | 1.1 | 7.4 | 93 | 4023 0684 00 |
| 14.3 | 1.2 | 8.9 | 96 | 4023 0949 00 |
| 15.9 | 1.3 | 10.0 | 95 | 4023 0685 00 |

HEX BITS

Application: For Hex-socket screws
Drive: 1/4" Hexagon, Style E 6.3



| Point mm | Length mm | Ordering No. |
|----------|-----------|--------------|
| 2 | 49 | 4023 1311 00 |
| 2.5 | 49 | 4023 1312 00 |
| 3 | 49 | 4023 0710 00 |
| 4 | 49 | 4023 0711 00 |
| 5 | 49 | 4023 0712 00 |
| 6.35 | 49 | 4023 0906 00 |
| 8 | 49 | 4023 1369 00 |
| 10 | 49 | 4023 1370 00 |

PHILLIPS BITS

Application: For Phillips screws
Drive: 1/4" Hexagon, Style E 6.3



| Point | Length mm | Ordering No. |
|-------|-----------|--------------|
| PH00 | 50 | 4023 0001 51 |
| PH00 | 70 | 4023 0001 52 |
| PH00 | 90 | 4023 0001 53 |
| PH0 | 50 | 4023 1325 00 |
| PH1 | 50 | 4023 2320 21 |
| PH1 | 70 | 4023 2327 21 |
| PH1 | 89 | 4023 2335 21 |
| PH1 | 152 | 4023 2360 21 |
| PH2 | 50 | 4023 2320 22 |
| PH2 | 70 | 4023 2327 22 |
| PH2 | 89 | 4023 2335 22 |
| PH2 | 152 | 4023 2360 22 |
| PH3 | 50 | 4023 2320 23 |
| PH3 | 70 | 4023 2327 23 |
| PH3 | 89 | 4023 2335 23 |
| PH3 | 152 | 4023 2360 23 |

TORX BITS

Application: For Torx screws
Drive: 1/4" Hexagon, Style E 6.3

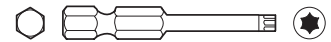

| Point | Length mm | Ordering No. |
|-------|-----------|--------------|
| TX5 | 49 | 4023 0002 16 |
| TX5 | 70 | 4023 0002 17 |
| TX6 | 49 | 4023 0001 61 |
| TX6 | 70 | 4023 0001 62 |
| TX6 | 90 | 4023 0001 63 |
| TX7 | 49 | 4023 0002 18 |
| TX7 | 70 | 4023 0002 19 |
| TX8 | 49 | 4023 2220 21 |
| TX8 | 90 | 4023 2235 21 |
| TX9 | 49 | 4023 2220 22 |
| TX9 | 90 | 4023 2235 22 |
| TX10 | 49 | 4023 2220 23 |
| TX10 | 90 | 4023 2235 23 |
| TX15 | 49 | 4023 2220 24 |
| TX15 | 90 | 4023 2235 24 |
| TX20 | 49 | 4023 2220 25 |
| TX20 | 90 | 4023 2235 25 |
| TX25 | 49 | 4023 2220 26 |
| TX25 | 90 | 4023 2235 26 |
| TX27 | 49 | 4023 2220 27 |
| TX27 | 90 | 4023 2235 27 |
| TX30 | 49 | 4023 2220 28 |
| TX30 | 90 | 4023 2235 28 |
| TX40 | 90 | 4023 2235 29 |

TORXPLUS BITS

Application: For TorxPlus screws
Drive: 1/4" Hexagon, Style E 6.3

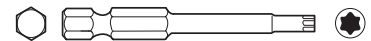

| Point | Length mm | Ordering No. |
|-------|-----------|--------------|
| IP5 | 50 | 4023 0002 20 |
| IP5 | 70 | 4023 0002 21 |
| IP6 | 50 | 4023 0001 71 |
| IP6 | 70 | 4023 0001 72 |
| IP6 | 90 | 4023 0001 73 |
| IP7 | 50 | 4023 0002 23 |
| IP7 | 70 | 4023 0002 24 |
| IP7 | 90 | 4023 0002 25 |
| IP8 | 50 | 4023 0001 75 |
| IP8 | 70 | 4023 0001 76 |
| IP8 | 90 | 4023 0001 77 |
| IP10 | 50 | 4023 0001 79 |
| IP10 | 70 | 4023 0001 80 |
| IP10 | 90 | 4023 0001 81 |

POZIDRIV BITS



Application: For Pozidriv screws
Drive: 1/4" Hexagon, Style E 6.3

| Point | Length mm | Ordering No. |
|-------|--------------|--------------|
| PZ0 | 50 | 4023 0001 41 |
| PZ0 | 70 | 4023 0001 42 |
| PZ1 | 50 | 4023 2420 21 |
| PZ1 | 70 | 4023 2427 21 |
| PZ1 | 89 | 4023 2435 21 |
| PZ2 | 50 | 4023 2420 22 |
| PZ2 | 70 | 4023 2427 22 |
| PZ2 | 70 | 4023 2435 22 |
| PZ3 | 50 | 4023 2420 23 |
| PZ3 | 89 | 4023 2435 23 |

DRIVE SYSTEM: 7/16" HEXAGON

SCREW PROFILE:



HEX BITS

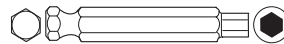

Application: For Hex-socket screws
Drive: 7/16" Hexagon

| Point mm | Length mm | Ordering No. |
|-------------|--------------|--------------|
| 5 | 70 | 4023 0800 00 |
| 6 | 70 | 4023 0801 00 |
| 8 | 70 | 4023 0802 00 |
| 10 | 70 | 4023 0760 00 |

Bit Holders

DRIVE SYSTEM: 1/4" HEXAGON, STYLE E 6.3

APPLICATION: SUITABLE FOR BITS WITH 1/4" HEXAGON DRIVE



STANDARD TYPE

| Hex-drive | Hex-female | Dia-meter (D) mm | Length L mm | Length L1 mm | Magnetic | Ordering No. |
|-----------|------------|---------------------|-------------------|--------------------|----------|--------------|
| 1/4" | 1/4" | 11.1 | 46.5 | 28.5 | Yes | 4023 1208 01 |
| 1/4" | 1/4" | 11.1 | 46.5 | 55.5 | Yes | 4023 1208 02 |
| 1/4" | 1/4" | 11.1 | 46.5 | 103.7 | Yes | 4023 1209 00 |

Adapters

DRIVE SYSTEM: 1/4" HEXAGON, STYLE E 6.3

APPLICATION: FOR BITS WITH WING-SHANK 4 MM DRIVE

ADAPTERS

| | Ordering No. |
|---------|--------------|
| Adapter | 4220 0105 00 |

Screwdriver Bits – Wing-shank Drive

DRIVE SYSTEM: 4 MM WING-SHANK

SCREW PROFILE:



SLOTTED BITS

Application: For Slotted screws
Drive: Wing-shank 4 mm

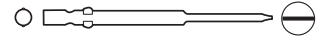

| Blade thickness mm | Blade width mm | Length mm | Ordering No. |
|-----------------------|-------------------|--------------|--------------|
| 0.28 | 1.3 | 60 | 4023 1327 01 |
| 0.30 | 1.7 | 60 | 4023 1327 02 |
| 0.3 | 2.0 | 60 | 4023 1327 03 |
| 0.3 | 2.5 | 60 | 4023 1327 04 |

PHILLIPS BITS

Application: For Phillips screws
Drive: Wing-shank 4 mm

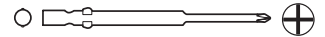

| Point | Length mm | Ordering No. |
|-------|--------------|--------------|
| PH00 | 40 | 4023 0002 56 |
| PH0 | 40 | 4023 0002 57 |
| PH1 | 40 | 4023 0002 58 |
| PH2 | 40 | 4023 0002 59 |

HEX BITS

Application: For Hex screws
Drive: Wing-shank 4 mm

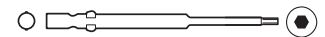

| Point | Length mm | Ordering No. |
|-------|--------------|--------------|
| 1.5 | 60 | 4023 0002 60 |
| 2 | 60 | 4023 0002 61 |
| 2.5 | 60 | 4023 0002 62 |
| 3 | 60 | 4023 0002 63 |

TORX BITS

Application: For Torx screws
Drive: Wing-shank 4 mm

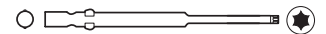

| Point | Length mm | Ordering No. |
|-------|--------------|--------------|
| TX1 | 40 | 4023 0002 52 |
| TX2 | 60 | 4023 0002 53 |
| TX3 | 60 | 4023 0002 54 |
| TX4 | 60 | 4023 0001 90 |
| TX5 | 60 | 4023 0001 91 |
| TX6 | 60 | 4023 0001 92 |
| TX8 | 60 | 4023 0001 93 |
| TX10 | 60 | 4023 0001 94 |

Bits and Sockets

TORXPLUS BITS

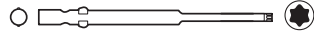

Application: For TorxPlus screws
Drive: Wing-shank 4 mm

| Point | Length mm | Ordering No. |
|-------|-----------|--------------|
| IP4 | 60 | 4023 0002 10 |
| IP5 | 60 | 4023 0002 11 |
| IP6 | 60 | 4023 0002 12 |
| IP8 | 60 | 4023 0002 13 |
| IP10 | 60 | 4023 0002 14 |

POZIDRIV BITS

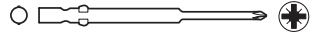

Application: For Pozidriv screws
Drive: Wing-shank 4 mm

| Point | Length mm | Ordering No. |
|-------|-----------|--------------|
| PZ0 | 60 | 4023 0002 03 |
| PZ1 | 60 | 4023 0002 04 |
| PZ2 | 60 | 4023 0002 55 |

Screwdriver Bits – Halfmoon Drive

DRIVE SYSTEM: 4 MM HALFMOON

SCREW PROFILE:



SLOTTED BITS



Application: For slotted screws
Drive: Halfmoon 4 mm

| Blade width mm | Blade thickness mm | Length mm | Ordering No. |
|----------------|--------------------|-----------|--------------|
| 2 | 0.3 | 44 | 4023 0002 37 |
| 2.5 | 0.3 | 44 | 4023 0002 38 |
| 3 | 0.4 | 44 | 4023 0002 39 |
| 4 | 0.5 | 44 | 4023 0002 40 |

PHILLIPS BITS



Application: For Phillips screws
Drive: Halfmoon 4 mm

| Point | Length mm | Ordering No. |
|-------|-----------|--------------|
| PH00 | 44 | 4023 0001 12 |
| PH00 | 64 | 4023 0001 13 |
| PH0 | 44 | 4023 0001 14 |
| PH0 | 64 | 4023 0001 15 |
| PH1 | 44 | 4023 0001 16 |
| PH1 | 64 | 4023 0001 17 |
| PH1 | 90 | 4023 0001 18 |
| PH2 | 44 | 4023 0002 30 |
| PH2 | 64 | 4023 0002 31 |

HEX BITS



Application: For Hex-socket screws
Drive: Halfmoon 4 mm

| Point | Length mm | Ordering No. |
|-------|-----------|--------------|
| 1.5 | 44 | 4023 0002 41 |
| 2 | 44 | 4023 0002 42 |
| 2.5 | 44 | 4023 0002 43 |
| 3 | 44 | 4023 0002 44 |

HEX-SOCKET BITS



Nutsetter. Application: For nuts and thread-headed screws
Drive: Halfmoon 4 mm

| Point | Length mm | Ordering No. |
|-------|-----------|--------------|
| 2.3 | 44 | 4023 0002 45 |
| 2.5 | 44 | 4023 0002 46 |
| 3 | 44 | 4023 0002 47 |
| 4 | 44 | 4023 0002 48 |
| 4.5 | 44 | 4023 0002 49 |
| 5 | 44 | 4023 0002 50 |
| 5.5 | 44 | 4023 0002 51 |

TORX BITS



Application: For Torx screws
Drive: Halfmoon 4 mm

| Point | Length mm | Ordering No. |
|-------|-----------|--------------|
| TX1 | 44 | 4023 0002 32 |
| TX2 | 44 | 4023 0001 06 |
| TX3 | 44 | 4023 0001 08 |
| TX3 | 64 | 4023 0001 09 |
| TX4 | 44 | 4023 0001 20 |
| TX4 | 64 | 4023 0001 21 |
| TX5 | 44 | 4023 0001 22 |
| TX5 | 64 | 4023 0001 23 |
| TX6 | 44 | 4023 0001 24 |
| TX6 | 64 | 4023 0001 25 |
| TX8 | 44 | 4023 0001 26 |
| TX8 | 64 | 4023 0001 27 |
| TX10 | 44 | 4023 0001 28 |
| TX10 | 64 | 4023 0001 29 |

TORXPLUS BITS



Application: For TorxPlus screws
Drive: Halfmoon 4 mm

| Point | Length mm | Ordering No. |
|-------|-----------|--------------|
| IP2 | 44 | 4023 0002 35 |
| IP3 | 44 | 4023 0002 36 |
| IP4 | 44 | 4023 0001 30 |
| IP4 | 64 | 4023 0001 31 |
| IP5 | 44 | 4023 0001 32 |
| IP5 | 64 | 4023 0001 33 |
| IP6 | 44 | 4023 0001 34 |
| IP6 | 64 | 4023 0001 35 |
| IP8 | 44 | 4023 0001 36 |
| IP8 | 64 | 4023 0001 37 |
| IP10 | 44 | 4023 0001 38 |
| IP10 | 64 | 4023 0001 39 |

POZIDRIV BITS



Application: For Pozidriv screws
Drive: Halfmoon 4 mm

| Point | Length mm | Ordering No. |
|-------|-----------|--------------|
| PZ0 | 44 | 4023 0002 26 |
| PZ0 | 64 | 4023 0002 27 |
| PZ1 | 44 | 4023 0002 28 |
| PZ1 | 64 | 4023 0002 29 |

Adapters

DRIVE SYSTEM: 4 MM HALFMOON

**APPLICATION: SUITABLE FOR BITS WITH
1/4" HEXAGON DRIVE**

ADAPTERS

| | Ordering No. |
|----------|--------------|
| Magnetic | 4023 0002 15 |

Sockets

SOCKETS 1/4" SQUARE DRIVE

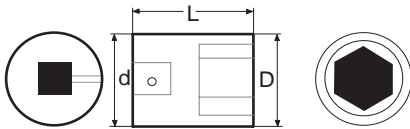

| | Width across flats | D mm | d mm | Overall length L mm | Ordering No. | Pin and O-ring ref. letter | |
|-------|--------------------------|---------|---------|------------------------------|--------------|-------------------------------------|---|
| mm | 4 | 7.5 | 13 | 23 | 4027 1100 04 | Z | |
| | 5 | 8.8 | 13 | 23 | 4027 1100 05 | Z | |
| | 5.5 | 9.4 | 13 | 23 | 4027 1100 55 | Z | |
| | 6 | 10.0 | 13 | 23 | 4027 1100 06 | Z | |
| | 7 | 11.3 | 13 | 23 | 4027 1100 07 | Z | |
| | 8 | 12.5 | 13 | 23 | 4027 1100 08 | Z | |
| | 9 | 13.8 | 13 | 23 | 4027 1100 09 | Z | |
| | 10 | 15.0 | 13 | 23 | 4027 1100 10 | Z | |
| | 11 | 16.3 | 13 | 23 | 4027 1100 11 | Z | |
| | 12 | 17.5 | 13 | 23 | 4027 1100 12 | Z | |
| | 13 | 18.8 | 13 | 23 | 4027 1100 13 | Z | |
| | 14 | 20 | 13 | 23 | 4027 1100 14 | Z | |
| | in | 7/32 | 9.4 | 13 | 23 | 4027 1100 97 | Z |
| | | 1/4 | 10.0 | 13 | 23 | 4027 1100 96 | Z |
| 9/32 | | 11.3 | 13 | 23 | 4027 1100 94 | Z | |
| 5/16 | | 12.5 | 13 | 23 | 4027 1100 93 | Z | |
| 3/8 | | 15.0 | 13 | 23 | 4027 1100 91 | Z | |
| 13/32 | | 15.0 | 13 | 23 | 4027 1100 89 | Z | |
| 7/16 | | 16.3 | 13 | 23 | 4027 1100 88 | Z | |
| 15/32 | | 17.5 | 13 | 23 | 4027 1100 12 | Z | |
| 1/2 | 18.8 | 13 | 23 | 4027 1100 86 | Z | | |
| 9/16 | 20 | 13 | 23 | 4027 1100 84 | Z | | |

See table for pin and o-ring.

SOCKETS 3/8" SQUARE DRIVE

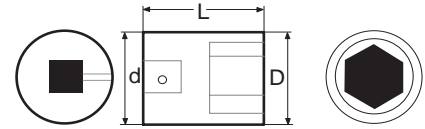

| | Width across flats | D mm | d mm | Overall length L mm | Ordering No. | Pin and O-ring ref. letter | |
|-----|--------------------------|---------|---------|------------------------------|--------------|-------------------------------------|---|
| mm | 7 | 12 | 19 | 32 | 4027 1200 07 | Y | |
| | 8 | 13.3 | 19 | 32 | 4027 1200 08 | Y | |
| | 9 | 14.5 | 19 | 32 | 4027 1200 09 | Y | |
| | 10 | 15.8 | 19 | 32 | 4027 1200 10 | Y | |
| | 11 | 17 | 19 | 32 | 4027 1200 11 | Y | |
| | 12 | 18.3 | 19 | 32 | 4027 1200 12 | Y | |
| | 13 | 19.5 | 22 | 32 | 4027 1200 13 | X | |
| | 14 | 20.8 | 22 | 32 | 4027 1200 14 | X | |
| | 16 | 23.3 | 22 | 32 | 4027 1200 16 | X | |
| | 17 | 24.5 | 22 | 32 | 4027 1200 17 | X | |
| | 18 | 25.8 | 22 | 32 | 4027 1200 18 | X | |
| | 19 | 27 | 22 | 32 | 4027 1200 19 | X | |
| | in | 5/16 | 13.3 | 19 | 32 | 4027 1200 93 | Y |
| | | 3/8 | 15.8 | 19 | 32 | 4027 1200 91 | Y |
| | | 13/32 | 15.8 | 19 | 32 | 4027 1200 89 | Y |
| | | 7/16 | 17 | 19 | 32 | 4027 1200 88 | Y |
| | | 15/32 | 18.3 | 19 | 32 | 4027 1200 87 | Y |
| | | 1/2 | 19.5 | 22 | 32 | 4027 1200 86 | X |
| | | 9/16 | 20.8 | 22 | 32 | 4027 1200 84 | X |
| 3/4 | | 27 | 22 | 32 | 4027 1200 81 | X | |

See table for pin and o-ring.

SOCKETS 1/2" SQUARE DRIVE

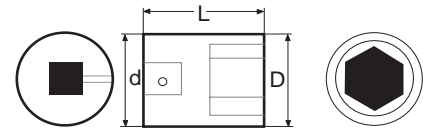

| | Width across flats | D mm | d mm | Overall length L mm | Ordering No. | Pin and O-ring ref. letter | |
|----|--------------------------|---------|---------|------------------------------|--------------|-------------------------------------|---|
| mm | 10 | 17 | 25 | 38 | 4027 1300 10 | W | |
| | 11 | 18.2 | 25 | 38 | 4027 1300 11 | W | |
| | 12 | 19.5 | 25 | 38 | 4027 1300 12 | W | |
| | 13 | 20.7 | 25 | 38 | 4027 1300 13 | W | |
| | 14 | 22 | 25 | 38 | 4027 1300 14 | W | |
| | 16 | 24.5 | 30 | 38 | 4027 1300 16 | V | |
| | 17 | 25.7 | 30 | 38 | 4027 1300 17 | V | |
| | 18 | 27 | 30 | 38 | 4027 1300 18 | V | |
| | 19 | 28.2 | 30 | 38 | 4027 1300 19 | V | |
| | 21 | 30.7 | 30 | 38 | 4027 1300 21 | V | |
| | 22 | 32 | 30 | 38 | 4027 1300 22 | V | |
| | 23 | 33.2 | 30 | 38 | 4027 1300 23 | V | |
| | 24 | 34.5 | 30 | 38 | 4027 1300 24 | V | |
| | in | 27 | 38.2 | 30 | 40 | 4027 1300 27 | V |
| | | 3/8 | 17 | 25 | 38 | 4027 1300 91 | W |
| | | 7/16 | 18.2 | 25 | 38 | 4027 1300 88 | W |
| | | 1/2 | 20.7 | 25 | 38 | 4027 1300 86 | W |
| | | 9/16 | 22 | 25 | 38 | 4027 1300 84 | W |
| | | 3/4 | 28.2 | 30 | 38 | 4027 1300 81 | V |
| | | 15/16 | 34.5 | 30 | 38 | 4027 1300 77 | V |
| | | 1 1/8 | 40.7 | 30 | 42 | 4027 1300 98 | V |

See table for pin and o-ring.

Bits and Sockets

SOCKETS 3/4" SQUARE DRIVE

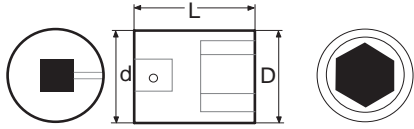

| | Width across flats | D mm | d mm | Overall length L mm | Ordering No. | Pin and O-ring ref. letter | |
|--------|--------------------|-------|------|---------------------|--------------|----------------------------|---|
| mm | 18 | 31.3 | 44 | 50 | 4027 1500 18 | U | |
| | 19 | 32.5 | 44 | 50 | 4027 1500 19 | U | |
| | 21 | 35 | 44 | 50 | 4027 1500 21 | U | |
| | 22 | 36.3 | 44 | 50 | 4027 1500 22 | U | |
| | 24 | 38.8 | 44 | 50 | 4027 1500 24 | U | |
| | 27 | 42.5 | 44 | 50 | 4027 1500 27 | U | |
| | 30 | 46.3 | 44 | 53 | 4027 1500 30 | U | |
| | 32 | 48.8 | 44 | 53 | 4027 1500 32 | U | |
| | 34 | 51.3 | 44 | 55 | 4027 1500 34 | U | |
| | 36 | 53.8 | 44 | 55 | 4027 1500 36 | U | |
| | in | 3/4 | 32.5 | 44 | 50 | 4027 1500 81 | U |
| | | 15/16 | 38.8 | 44 | 50 | 4027 1500 77 | U |
| 1 1/8 | | 45 | 44 | 53 | 4027 1500 98 | U | |
| 1 5/16 | | 51.3 | 44 | 55 | 4027 1500 94 | U | |
| 1 1/2 | | 56.3 | 44 | 57 | 4027 1500 91 | U | |

See table for pin and o-ring.

SOCKETS 1 1/2" SQUARE DRIVE

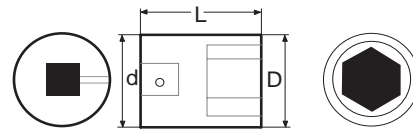

| | Width across flats | D mm | d mm | Overall length L mm | Ordering No. | Pin and O-ring ref. letter |
|----|--------------------|------|------|---------------------|--------------|----------------------------|
| mm | 50 | 79 | 86 | 84 | 4027 1700 50 | S |
| | 55 | 85 | 86 | 90 | 4027 1700 55 | S |
| | 60 | 91 | 86 | 90 | 4027 1700 60 | S |
| | 65 | 97 | 86 | 95 | 4027 1700 65 | S |
| | 70 | 103 | 86 | 100 | 4027 1700 70 | S |
| | 75 | 108 | 86 | 105 | 4027 1700 75 | S |
| | 80 | 115 | 86 | 110 | 4027 1700 80 | S |

See table for pin and o-ring.

Stud setter

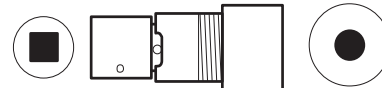

SOCKETS 1" SQUARE DRIVE

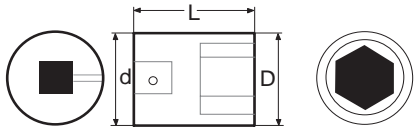

| 1" | Width across flats | D mm | d mm | Overall length L mm | Ordering No. | Pin ^a and O-ring ref. letter |
|----|--------------------|------|------|---------------------|--------------|---|
| mm | 24 | 41.5 | 54 | 57 | 4027 1600 24 | T |
| | 27 | 45.3 | 54 | 57 | 4027 1600 27 | T |
| | 30 | 49 | 54 | 62 | 4027 1600 30 | T |
| | 32 | 51.5 | 54 | 62 | 4027 1600 32 | T |
| | 34 | 54 | 54 | 62 | 4027 1600 34 | T |
| | 36 | 56.5 | 54 | 62 | 4027 1600 36 | T |
| | 41 | 62.8 | 54 | 66 | 4027 1600 41 | T |
| | 46 | 69 | 54 | 70 | 4027 1600 46 | T |
| | 50 | 74 | 54 | 70 | 4027 1600 50 | T |
| | 55 | 80.3 | 54 | 75 | 4027 1600 55 | T |
| | 60 | 86.5 | 54 | 75 | 4027 1600 60 | T |
| | 65 | 92.8 | 54 | 75 | 4027 1600 65 | T |
| in | 15/16 | 41.5 | 54 | 57 | 4027 1600 77 | T |
| | 1 1/8 | 47.8 | 54 | 57 | 4027 1600 98 | T |
| | 1 5/16 | 54 | 54 | 62 | 4027 1600 94 | T |
| | 1 11/16 | 65.3 | 54 | 68 | 4027 1600 87 | T |
| | 1 7/8 | 71.5 | 54 | 70 | 4027 1600 83 | T |

See table for pin and o-ring.

| Square drive in | Ordering No. | Holder drive nut | Ordering No. |
|-----------------|--------------|------------------|--------------|
| 1/2 | 4023 0752 80 | M6 | 4023 0761 00 |
| | | M8 | 4023 0762 00 |
| | | M10 | 4023 0756 00 |
| | | M12 | 4023 0757 00 |

Universal joints

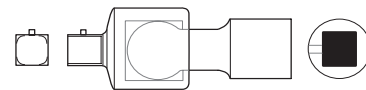

| Male square in | Square drive in | Diameter mm | Length mm | Ordering No. | Pin and O-ring ref. letter |
|----------------|-----------------|-------------|-----------|--------------|----------------------------|
| 3/8 | 3/8 | 22 | 56 | 4027 1235 40 | X |
| 1/2 | 1/2 | 30 | 74 | 4027 1335 40 | V |
| 5/8 | 5/8 | 38 | 69 | 4023 0875 00 | |
| 3/4 | 3/4 | 44 | 106 | 4027 1535 40 | U |
| 1 | 1 | 54 | 127 | 4027 1635 40 | T |
| 1 1/2 | 1 1/2 | 84 | 162 | 4023 1316 00 | F |

See table for pin and o-ring.

Socket adapters

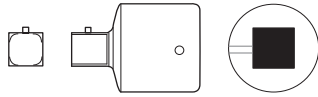

| Male square in | Square drive in | Diameter mm | Length mm | Ordering No. | Pin ^a and O-ring ref. letter |
|----------------|-----------------|-------------|-----------|--------------|---|
| 1/2 | 3/8 | 22 | 32.5 | 4027 1235 31 | X |
| 3/8 | 1/2 | 25 | 36 | 4027 1335 30 | W |
| 5/8 | 1/2 | 30 | 42 | 4027 1335 21 | V |
| 1/2 | 5/8 | 35 | 46 | 4027 1435 20 | V |
| 3/4 | 5/8 | 38 | 54 | 4023 1156 00 | |
| 1/2 | 3/4 | 44 | 52 | 4027 1535 30 | U |
| 1 | 3/4 | 44 | 62 | 4027 1535 22 | U |
| 3/4 | 1 | 54 | 66.5 | 4027 1635 20 | T |
| 1 | 1 1/2 | 86 | 98 | 4027 1735 20 | S |

See table for pin and o-ring.

Extensions

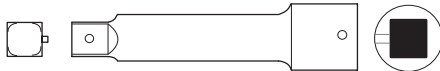

| Male square in | Square drive in | Diameter mm | Length mm | Ordering No. | Pin and O-ring ref. letter |
|----------------|-----------------|-------------|-----------|--------------|----------------------------|
| 3/8 | 3/8 | 22 | 150 | 4027 1234 04 | X |
| 1/2 | 1/2 | 30 | 125 | 4027 1334 03 | V |
| 1/2 | 1/2 | 30 | 250 | 4027 1334 07 | V |
| 5/8 | 5/8 | 33 | 152 | 4023 0749 00 | |
| 3/4 | 3/4 | 44 | 175 | 4027 1534 15 | U |
| 3/4 | 3/4 | 44 | 330 | 4027 1534 18 | U |
| 1 | 1 | 54 | 175 | 4027 1634 15 | T |
| 1 | 1 | 54 | 330 | 4027 1634 18 | T |
| 1 1/2 | 1 1/2 | 86 | 330 | 4027 1734 18 | S |

See table for pin and o-ring.

Quick change chuck for power bits

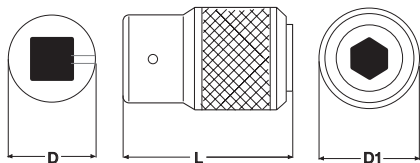

| Square drive in | Female hex in | Diameter D mm | Diameter D1 mm | Length L mm | Ordering No. | Pin and O-ring ref. letter |
|-----------------|---------------|---------------|----------------|-------------|--------------|----------------------------|
| 3/8 | 1/4 | 22 | 22 | 46 | 4027 1236 01 | X |
| 3/8 | 5/16 | 22 | 33 | 55 | 4023 1382 00 | |
| 3/8 | 7/16 | 22 | 33 | 45 | 4027 1236 03 | X |
| 1/2 | 7/16 | 30 | 33 | 55 | 4027 1336 03 | V |

See table for pin and o-ring.

Locking pins and O-rings



| Ref. letter | Locking pin | | O-ring | | Pin and O-ring Ordering No. |
|----------------|-------------|-----------|-------------|-------------------|-----------------------------|
| | Diameter mm | Length mm | Diameter mm | Inner diameter mm | |
| A ^b | 4 | 35 | 5 | 33 | 4026 5000 90 |
| B | 4 | 45 | 5 | 33 | 4026 5000 91 |
| C | 5 | 45 | 6 | 44 | 4026 5000 92 |
| D | 5 | 60 | 6 | 59 | 4026 5000 93 |
| E | 5 | 70 | 6 | 65 | 4026 5000 94 |
| F | 6 | 75 | 6 | 65 | 4026 5000 95 |
| G | 6 | 75 | 6 | 79 | 4026 5000 96 |
| H | 6 | 95 | 6 | 94 | 4026 5000 97 |
| Z | 1.5 | 10 | 2.5 | 9 | 4027 1198 90 |
| Y | 2.5 | 14 | 3.5 | 13 | 4027 1298 90 |
| X | 2.5 | 16 | 3.5 | 16 | 4027 1298 91 |
| W | 3 | 20 | 4 | 19 | 4027 1398 90 |
| V | 3 | 25 | 4 | 24 | 4027 1398 91 |
| U | 4 | 35 | 5 | 36 | 4027 1598 90 |
| T | 5 | 45 | 7 | 45 | 4027 1698 90 |
| S | 6 | 75 | 10 | 75 | 4027 1798 90 |

^b B type pin also included.

Socket holders



| Hex in | Square in | Length mm | Ordering No. |
|--------|-----------|-----------|--------------|
| 1/4 | 1/4 | 50 | 4027 1017 00 |
| 1/4 | 1/4 | 75 | 4027 1017 01 |
| 1/4 | 1/4 | 100 | 4027 1017 02 |
| 1/4 | 1/4 | 150 | 4027 1017 04 |
| 1/4 | 3/8 | 50 | 4027 1017 10 |
| 1/4 | 3/8 | 75 | 4027 1017 11 |
| 1/4 | 3/8 | 100 | 4027 1017 12 |
| 7/16 | 3/8 | 70 | 4027 1018 01 |
| 7/16 | 1/2 | 70 | 4027 1018 11 |

FIXTURED APPLICATIONS

Contents

| | |
|-------------------------------|-----|
| Introduction..... | 175 |
| Fixtured nutrunners QST | 177 |
| Fixtured nutrunners ETX | 181 |
| Power MACS..... | 184 |
| MSB, DB, GB..... | 185 |
| Power Focus..... | 188 |
| ToolsTalk..... | 189 |

With our vast experience, we are a supplier you can rely on

Atlas Copco is the world-leading supplier of fixtured nutrunner systems. Our vast experience of designing components for multiple nutrunner systems, combined with knowledge of building, commissioning and maintaining fixtured solutions, makes Atlas Copco a supplier you can rely on.

For fixtured nutrunner systems, Atlas Copco offers a complete portfolio of products designed to satisfy your needs. These range from individual components to operator controlled Multiples by Express® stations and demanding stitching applications. There are two different systems designed for fixtured applications, as well as user-friendly controller software.

Please contact your local Atlas Copco sales representative who will be pleased to discuss your needs.

POWER MACS 4000 AND QST NUTRUNNERS

A state-of-the-art, stand-alone system offering high reliability, accuracy and capability. The system is designed with user friendliness in mind and is easy to build and integrate into production lines.

POWER FOCUS 4000 AND ETX NUTRUNNERS

A flexible solution that makes it possible to run durable and accurate fixtured nutrunners on the Power Focus controller designed for hand-held tools.

TOOLSTALK SOFTWARE

ToolsTalk software for Power MACS 4000 has been developed with user-friendliness and customer adaptation in mind. This Window-based program can be installed on a station PC, a laptop or a back office PC.



Power MACS 4000 stand alone system – small, cost efficient and powerful. No need for bulky cabinets.

Nutrunners to match your needs

The QST nutrunner is a true state-of-the-art product. Partnered with the Power MACS 4000 tightening controller, QST offers one of the most advanced and reliable tightening solutions on the market. ETX nutrunners are compact, durable and easy to integrate. Since ETX is controlled by the Power Focus, like the Tensor S and Tensor ST tools, it is possible to achieve 100% controller commonality in a line.

QST AND ETX NUTRUNNERS – COMMON FEATURES

Designed specifically for fixtured systems, these two reliable, durable nutrunners have many common features.

With QST and ETX nutrunners pilot mount or sandwich are possible. Different socket holder lengths (0-200 mm) permit access to applications or parts with tight clearances. For longer bolt lengths, spring travel can be increased from the standard 50 mm to 76 or 100 mm on request.

A built-in memory chip in QST and ETX nutrunners stores calibration values and general tool and service data. Both tools are ISO certified to +/- 2.5% accuracy and 1 million duty cycles on hard and soft joints.

QST AND ETX – DIFFERENT FEATURES

The QST nutrunner is available in inline, off-set, angle head, angle head travel, U-shaped, angle, SPN and co-axial designs. The ETX comes in inline, offset and angle head versions.

Connectors on both tools are designed to provide cable management flexibility. The robust connector and pin design on the QST is adjustable in 2 DOF. The ETX has a rotatable single connector.

QST offers a standard torque range of 2-1,750 Nm (up to 8,000 on request) and has a 60 m cable. ETX has a torque range of 6-950 Nm and a cable length of 25 m.

QST NUTRUNNERS – EXTRA FEATURES

- Digital communication between nutrunner and controller.
- Hot Swap – replace cable or spindle without turning off the power.
- Increased speed characteristics, up to 3,000 rpm.
- Optional redundant angle encoder and transducer.
- MTBF better than 5 million cycles under normal conditions.



- Inline nutrunner, CT – Equipped with commutation sensor and transducer.
- Off-set nutrunner, COT – Comes with a commutation sensor, off-set gears for narrow bolts and transducer.
- Extended spring travel 76 mm and 100 mm – Nutrunners with extended spring travel for longer bolt lengths.
- Dual transducers, CTT – Nutrunners with dual torque transducer feedback.
- Dual transducers and angle feedback, CATT – Nutrunners with dual angle and torque transducer feedback.
- Angle head nutrunners, CTV – Nutrunners with angle heads. Available with or without travel.



QST COT



QST CT

| Model | Travel mm | Torque range | | Speed r/min | Min C-C | Weight | | Gear ratio | Socket holder size in | Ordering No. |
|--|--------------|--------------|----------|----------------|------------|--------|------|---------------|--------------------------------|--------------|
| | | Nm | ft lb | | | kg | lb | | | |
| QST34-8CT-T50-L150-H6 | 50 | 2-8 | 1.5-6 | 3000 | 34 | 2 | 4.4 | 7.428 | 1/4 | 8435 6000 10 |
| QST34-20CT-T50-L150-H10 | 50 | 4-20 | 2.9-14.7 | 1000 | 34 | 2 | 4.4 | 21.2 | 3/8 | 8435 6010 10 |
| QST42-20CT-T50-L134 -H10 | 50 | 6-20 | 4-14 | 2000 | 43 | 3.1 | 6.9 | 7.50 | 3/8 | 8435 6020 10 |
| QST42-20COT-T50-L134-H10 | 50 | 6-20 | 4-14 | 2000 | 31 | 4.2 | 9.3 | 7.5 | 3/8 | 8435 6020 20 |
| QST42-50CT-T50-L134-H13 | 50 | 10-50 | 7-35 | 700 | 43 | 3.8 | 8.4 | 21.33 | 1/2 | 8435 6030 10 |
| QST42-50COT-T50-L134-H13 | 50 | 10-50 | 7-35 | 700 | 31 | 4.5 | 9.9 | 21.33 | 1/2 | 8435 6030 20 |
| QST50-90CT-T50-L137-H13 | 50 | 20-90 | 15-65 | 650 | 51 | 5.8 | 12.7 | 18.21 | 1/2 | 8435 6040 10 |
| QST50-90COT-T50-L137-H13 | 50 | 20-90 | 15-65 | 650 | 37 | 7.8 | 17.2 | 18.21 | 1/2 | 8435 6040 20 |
| QST50-150CT-T50-L137-H13 | 50 | 30-150 | 22-110 | 380 | 51 | 5.8 | 12.8 | 31.24 | 1/2 | 8435 6050 10 |
| QST50-150COT-T50-L137-H13 | 50 | 30-150 | 22-110 | 380 | 37 | 7.8 | 17.2 | 31.24 | 1/2 | 8435 6050 20 |
| QST62-150CT-T50-L152-H13 | 50 | 30-150 | 22-110 | 450 | 63 | 10.2 | 22.5 | 13.94 | 1/2 | 8435 6060 10 |
| QST62-150COT-T50-L152 -H13 | 50 | 30-150 | 22-110 | 450 | 45 | 12.8 | 28.2 | 13.94 | 1/2 | 8435 6060 20 |
| QST62-230CT-T50-L152-H19 | 50 | 40-230 | 29-170 | 330 | 63 | 10.2 | 22.5 | 19.04 | 3/4 | 8435 6065 10 |
| QST62-230COT-T50-L152-H19 | 50 | 40-220 | 29-162 | 330 | 45 | 12.8 | 28.2 | 19.04 | 3/4 | 8435 6065 20 |
| QST62-350CT-T50-L152-H19 | 50 | 50-350 | 37-258 | 220 | 63 | 10.2 | 22.5 | 28.33 | 3/4 | 8435 6070 10 |
| QST62-350COT-T50-L152-H19 | 50 | 50-330 | 37-243 | 220 | 45 | 12.8 | 28.2 | 28.33 | 3/4 | 8435 6070 20 |
| QST80-450CT-T50-L146-H19 | 50 | 90-450 | 66-332 | 260 | 81 | 16.7 | 37 | 22.67 | 3/4 | 8435 6075 10 |
| QST80-450COT-T50-L146-H19 | 50 | 90-450 | 66-332 | 260 | 55 | 21 | 46 | 22.67 | 3/4 | 8435 6075 20 |
| QST80-600CT-T50-L146-H19 | 50 | 120-600 | 88-442 | 200 | 81 | 17 | 37 | 29.56 | 3/4 | 8435 6080 10 |
| QST80-600COT-T50-L146-H19 | 50 | 120-600 | 88-442 | 200 | 55 | 21 | 46 | 29.56 | 3/4 | 8435 6080 20 |
| QST90-750CT-T50-L152-H25 | 50 | 150-750 | 111-553 | 150 | 91 | 25 | 55 | 38.89 | 1 | 8435 6085 10 |
| QST90-750COT-T50-L152-H25 | 50 | 150-750 | 111-553 | 150 | 63 | 29 | 64 | 38.89 | 1 | 8435 6085 20 |
| QST90-1000CT-T50-L152-H25 | 50 | 200-1000 | 147-737 | 130 | 91 | 26 | 57 | 46.84 | 1 | 8435 6090 10 |
| QST90-1000COT-T50-L152-H25 | 50 | 200-1000 | 147-737 | 130 | 63 | 30 | 66 | 46.84 | 1 | 8435 6090 20 |
| QST95-1750CT-T50-L149-H38 | 50 | 350-1750 | 258-1291 | 60 | 96 | 28 | 61.7 | 98.21 | 1 1/2 | 8435 6095 10 |
| QST95-1750COT-T50-L155-H38 | 50 | 350-1750 | 258-1291 | 60 | 73 | 43 | 94.8 | 98.21 | 1 1/2 | 8435 6095 20 |
| Extended spring travel 76 mm and 100 mm | | | | | | | | | | |
| QST42-20CT-T76-L189-H10 | 76 | 6-20 | 4-14 | 2000 | 43 | 3.1 | 6.9 | 7.5 | 3/8 | 8435 6020 11 |
| QST42-50CT-T76-L189-H13 | 76 | 10-50 | 7-35 | 700 | 43 | 3.8 | 8.4 | 21.3 | 1/2 | 8435 6030 11 |
| QST50-90CT-T76-L200-H13 | 76 | 20-90 | 15-65 | 650 | 51 | 5.8 | 12.7 | 18.2 | 1/2 | 8435 6040 11 |
| QST50-150CT-T76-L200-H13 | 76 | 30-150 | 22-110 | 380 | 51 | 5.8 | 12.8 | 31.2 | 1/2 | 8435 6050 11 |
| QST62-230CT-T76-L200-H19 | 76 | 40-230 | 29-170 | 330 | 63 | 10.2 | 22.5 | 19 | 3/4 | 8435 6065 11 |
| QST62-350CT-T76-L200-H19 | 76 | 50-350 | 37-258 | 220 | 63 | 10.2 | 22.5 | 28.3 | 3/4 | 8435 6070 11 |
| QST80-450CT-T76-L214-H19 | 76 | 90-450 | 66-332 | 260 | 81 | 17 | 37 | 22.67 | 3/4 | 8435 6075 11 |
| QST80-600CT-T76-L214-H19 | 76 | 120-600 | 88-442 | 200 | 81 | 17 | 37 | 29.6 | 3/4 | 8435 6080 11 |
| QST90-750CT-T76-L176-H25 | 76 | 150-750 | 111-553 | 150 | 63 | 29 | 64 | 38.89 | 1 | 8435 6085 11 |
| QST90-1000CT-T76-L176-H25 | 76 | 200-1000 | 147-737 | 130 | 91 | 26 | 57 | 46.8 | 1 | 8435 6090 11 |
| QST42-50CT-T100-L191-H13 | 100 | 10-50 | 7-35 | 700 | 43 | 3.8 | 8.4 | 21.3 | 1/2 | 8435 6030 12 |
| QST50-150CT-T100-L186-H13 | 100 | 30-150 | 22-110 | 380 | 51 | 5.8 | 12.8 | 31.2 | 1/2 | 8435 6050 12 |

| Model | Travel mm | Torque range | | Speed r/min | Min C-C | Weight | | Gear ratio | Socket holder size in | Ordering No. |
|--|--------------|--------------|---------|----------------|------------|--------|------|---------------|--------------------------------|--------------|
| | | Nm | ft lb | | | kg | lb | | | |
| Dual transducers, CTT | | | | | | | | | | |
| QST42-20CTT-T50-L134-H10 | 50 | 6-20 | 4-14 | 2000 | 43 | 3.1 | 6.9 | 7.5 | 3/8 | 8435 6020 50 |
| QST42-20COTT-T50-L134-H10 | 50 | 6-20 | 4-14 | 2000 | 31 | 4.2 | 9.3 | 7.5 | 3/8 | 8435 6020 60 |
| QST42-50CTT-T50-L134-H13 | 50 | 10-50 | 7-35 | 700 | 43 | 3.8 | 8.4 | 21.33 | 1/2 | 8435 6030 50 |
| QST42-50COTT-T50-L134-H13 | 50 | 10-50 | 7-35 | 700 | 31 | 4.5 | 9.9 | 21.33 | 1/2 | 8435 6030 60 |
| QST50-90CTT-T50-L137-H13 | 50 | 20-90 | 15-65 | 650 | 51 | 5.8 | 12.7 | 18.21 | 1/2 | 8435 6040 50 |
| QST50-90COTT-T50-L137-H13 | 50 | 20-90 | 15-65 | 650 | 37 | 7.8 | 17.2 | 18.21 | 1/2 | 8435 6040 60 |
| QST50-150CTT-T50-L137-H13 | 50 | 30-150 | 22-110 | 380 | 51 | 5.8 | 12.8 | 31.24 | 1/2 | 8435 6050 50 |
| QST50-150COTT-T50-L137-H13 | 50 | 30-150 | 22-110 | 380 | 37 | 7.8 | 17.2 | 31.24 | 1/2 | 8435 6050 60 |
| QST62-150CTT-T50-L152-H13 | 50 | 30-150 | 22-110 | 450 | 63 | 10.2 | 22.5 | 13.94 | 1/2 | 8435 6060 50 |
| QST62-150COTT-T50-L152-H13 | 50 | 30-150 | 22-110 | 450 | 45 | 12.8 | 28.2 | 13.94 | 1/2 | 8435 6060 60 |
| QST62-230CTT-T50-L152-H19 | 50 | 40-230 | 29-170 | 330 | 63 | 10.2 | 22.5 | 19.04 | 3/4 | 8435 6065 50 |
| QST62-230COTT-T50-L152-H19 | 50 | 40-220 | 29-162 | 330 | 45 | 12.8 | 28.2 | 19.04 | 3/4 | 8435 6065 60 |
| QST62-350CTT-T50-L152-H19 | 50 | 50-350 | 37-258 | 220 | 63 | 10.2 | 22.5 | 28.33 | 3/4 | 8435 6070 50 |
| QST62-350COTT-T50-L152-H19 | 50 | 50-330 | 37-243 | 220 | 45 | 12.8 | 28.2 | 28.33 | 3/4 | 8435 6070 60 |
| QST80-450CTT-T50-L146-H19 | 50 | 90-450 | 66-332 | 260 | 81 | 16.7 | 37 | 22.67 | 3/4 | 8435 6075 50 |
| QST80-450COTT-T50-L146-H19 | 50 | 90-450 | 66-332 | 260 | 55 | 21 | 46 | 22.67 | 3/4 | 8435 6075 60 |
| QST80-600CTT-T50-L146-H19 | 50 | 120-600 | 88-442 | 200 | 81 | 17 | 37 | 29.56 | 3/4 | 8435 6080 50 |
| QST80-600COTT-T50-L146-H19 | 50 | 120-600 | 88-442 | 200 | 55 | 21 | 46 | 29.56 | 3/4 | 8435 6080 60 |
| QST90-750CTT-T50-L152-H25 | 50 | 150-750 | 111-553 | 150 | 91 | 25 | 55 | 38.89 | 1 | 8435 6085 50 |
| QST90-750COTT-T50-L152-H25 | 50 | 150-750 | 111-553 | 150 | 63 | 29 | 64 | 38.89 | 1 | 8435 6085 60 |
| QST90-1000CTT-T50-L152-H25 | 50 | 200-1000 | 147-737 | 130 | 91 | 26 | 57 | 46.84 | 1 | 8435 6090 50 |
| QST90-1000COTT-T50-L152-H25 | 50 | 200-1000 | 147-737 | 130 | 63 | 30 | 66 | 46.84 | 1 | 8435 6090 60 |
| Dual transducers and angle feedback, CATT | | | | | | | | | | |
| QST42-20CATT-T50-L134-H10 | 50 | 6-20 | 4-14 | 2000 | 43 | 3.1 | 6.9 | 7.5 | 3/8 | 8435 6020 70 |
| QST42-50CATT-T50-L134-H13 | 50 | 10-50 | 7-35 | 700 | 43 | 3.8 | 8.4 | 21.33 | 1/2 | 8435 6030 70 |
| QST50-90CATT-T50-L137-H13 | 50 | 20-90 | 15-65 | 650 | 51 | 5.8 | 12.7 | 18.21 | 1/2 | 8435 6040 70 |
| QST50-150CATT-T50-L137-H13 | 50 | 30-150 | 22-110 | 380 | 51 | 5.8 | 12.8 | 31.24 | 1/2 | 8435 6050 70 |
| QST62-150CATT-T50-L152-H13 | 50 | 30-150 | 22-110 | 450 | 63 | 10.2 | 22.5 | 13.94 | 1/2 | 8435 6060 70 |
| QST62-230CATT-T50-L152-H19 | 50 | 40-230 | 29-170 | 330 | 63 | 10.2 | 22.5 | 19.04 | 3/4 | 8435 6065 70 |
| QST62-350CATT-T50-L152-H19 | 50 | 50-350 | 37-258 | 220 | 63 | 10.2 | 22.5 | 28.33 | 3/4 | 8435 6070 70 |
| QST80-450CATT-T50-L146-H19 | 50 | 90-450 | 66-332 | 260 | 81 | 16.7 | 36.9 | 22.67 | 3/4 | 8435 6075 70 |
| QST80-600CATT-T50-L146-H19 | 50 | 120-600 | 88-442 | 200 | 81 | 17 | 37 | 29.56 | 3/4 | 8435 6080 70 |
| QST90-750CATT-T50-L152-H25 | 50 | 150-750 | 111-553 | 150 | 91 | 25 | 55 | 38.89 | 1 | 8435 6085 70 |
| QST90-1000CATT-T50-L152-H25 | 50 | 200-1000 | 147-737 | 130 | 91 | 26 | 57 | 46.84 | 1 | 8435 6090 70 |
| Angle head, CTV | | | | | | | | | | |
| QST42-20CTV-P10 | | 6-20 | 4-14 | 1200 | 28 | 3.5 | 7 | 11.6 | 3/8 | 9831 4077 27 |
| QST42-20CTV-T25-H10 | 25 | 6-20 | 4-14 | 1200 | 28 | 5 | 11 | 11.6 | 3/8 | 9831 4077 57 |
| QST42-30CTV-P10 | | 6-30 | 4.5-22 | 440 | 36 | 3.5 | 7 | 11.6 | 3/8 | 9831 4077 26 |
| QST42-30CTV-T25-H10 | 25 | 6-30 | 4.5-22 | 440 | 36 | 5.5 | 12 | 33 | 3/8 | 9831 4077 58 |
| QST42-70CTV-P13 | | 14-70 | 10-52 | 440 | 40 | 4.5 | 10 | 33 | 1/2 | 9831 4077 28 |
| QST42-70CTV-T25-H13 | 25 | 14-70 | 10-52 | 450 | 40 | 5.5 | 12 | 33 | 1/2 | 9831 4077 59 |
| QST50-170CTV-P13 | | 34-170 | 25-125 | 210 | 52 | 6.8 | 15 | 56.2 | 1/2 | 9831 4078 38 |
| QST50-170CTV-T50-H13 | 50 | 34-170 | 25-125 | 210 | 48 | 8.6 | 19 | 56.2 | 1/2 | 9831 4078 44 |
| QST50-200CTV-H19 | | 40-200 | 29-145 | 210 | 54 | 7 | 15 | 56.2 | 3/4 | 9831 4078 43 |
| QST50-200CTV-T25-H19 | 25 | 40-200 | 29-145 | 210 | 54 | 9.5 | 21 | 56.2 | 3/4 | 9831 4078 46 |
| QST50-200CTV-T50-H19 | 50 | 40-200 | 29-145 | 210 | 58 | 10 | 22 | 56.2 | 3/4 | 9831 4078 47 |
| QST62-350CTV-H19 | | 60-350 | 44-229 | 175 | 66 | 13.5 | 30 | 34.3 | 3/4 | 9831 4079 73 |
| QST62-350CTV-T25-H19 | 25 | 60-350 | 44-229 | 175 | 67 | 16.5 | 36 | 34.3 | 3/4 | 9831 4087 10 |
| QST62-600CTV-H25 | | 120-600 | 88-440 | 100 | 109 | 16.5 | 33 | 93.5 | 1 | 9831 4087 02 |

Dimensions

| Model | A mm | B mm | C mm | D mm | E mm |
|----------------------------|---------|---------|---------|---------|---------|
| Standard | | | | | |
| QST34-8CT-T50-L150-H6 | 150 | 16 | 359 | 10 | – |
| QST34-20CT-T50-L150-H10 | 150 | 16 | 359 | 10 | – |
| QST42-20CT-T50-L134-H10 | 134 | 23 | 395 | 15 | – |
| QST42-20COT-T50-L134-H10 | 134.5 | – | – | – | 446 |
| QST42-50CT-T50-L134-H13 | 134 | 23 | 422 | 15 | – |
| QST42-50COT-T50-L134-H13 | 134.5 | – | – | – | 472 |
| QST50-90CT-T50-L137-H13 | 137 | 23 | 464 | 15 | – |
| QST50-90COT-T50-L137-H13 | 137 | – | – | – | 521 |
| QST50-150CT-T50-L137-H13 | 137 | 23 | 464 | 15 | – |
| QST50-150COT-T50-L137-H13 | 137 | – | – | – | 521 |
| QST62-150CT-T50-L152-H19 | 152 | 25 | 517 | 15 | – |
| QST62-150COT-T50-L152-H19 | 152.5 | – | – | – | 586 |
| QST62-230CT-T50-L152-H19 | 152 | 25 | 517 | 15 | – |
| QST62-230COT-T50-L152-H19 | 152.5 | – | – | – | 586 |
| QST62-350CT-T50-L152-H19 | 152 | 25 | 517 | 15 | – |
| QST62-350COT-T50-L152-H19 | 152 | – | – | – | 592 |
| QST80-450CT-T50-L146-H19 | 146 | 30 | 595 | 20 | – |
| QST80-450COT-T50-L146-H19 | 146 | – | – | – | 685 |
| QST80-600CT-T50-L146-H19 | 146 | 30 | 595 | 20 | – |
| QST80-600COT-T50-L146-H19 | 146 | – | – | – | 685 |
| QST90-750CT-T50-L152-H25 | 152 | 32 | 600 | 20 | – |
| QST90-750COT-T50-L152-H25 | 153 | – | – | – | 705 |
| QST90-1000CT-T50-L152-H25 | 152 | 32 | 600 | 20 | – |
| QST90-1000COT-T50-L152-H25 | 153 | – | – | – | 710 |
| QST95-1750CT-T50-L149-H38 | 149 | 32 | 651 | 20 | – |
| QST95-1750COT-T50-L155-H38 | 155 | – | – | – | 796 |

| Model | A mm | B mm | C mm | D mm | E mm |
|--|---------|---------|---------|---------|---------|
| Dual transducers and angle feedback, CATT | | | | | |
| QST42-20CATT-T50-L134-H10 | 134 | 23 | 395 | 15 | – |
| QST42-50CATT-T50-L134-H13 | 134 | 23 | 422 | 15 | – |
| QST50-90CATT-T50-L137-H13 | 137 | 23 | 464 | 15 | – |
| QST50-150CATT-T50-L137-H13 | 137 | 23 | 464 | 15 | – |
| QST62-150CATT-T50-L152-H13 | 152 | 25 | 542 | 15 | – |
| QST62-230CATT-T50-L152-H19 | 152 | 25 | 542 | 15 | – |
| QST62-350CATT-T50-L152-H19 | 152 | 25 | 542 | 15 | – |
| QST80-450CATT-T50-L146-H19 | 146 | 30 | 595 | 20 | – |
| QST80-600CATT-T50-L146-H19 | 146 | 30 | 595 | 20 | – |
| QST90-750CATT-T50-L152-H25 | 152 | 32 | 600 | 20 | – |
| QST90-1000CATT-T50-L152-H25 | 152 | 32 | 600 | 20 | – |
| Angle head | | | | | |
| QST42-20CTV-P10 | 65 | – | – | 8 | 409 |
| QST42-20CTV-T25-H10 | – | – | – | – | – |
| QST42-30CTV-P10 | 83 | – | – | 8 | 435 |
| QST42-30CTV-T25-H10 | – | – | – | – | 525 |
| QST42-70CTV-P13 | 84 | – | – | 15 | 432 |
| QST42-70CTV-T25-H13 | – | – | – | – | 526 |
| QST50-170CTV-P13 | 135 | – | – | 15 | 481 |
| QST50-170CTV-T50-H13 | – | – | – | – | – |
| QST50-200CTV-H19 | 135 | – | – | 15 | 481 |
| QST50-200CTV-T25-H19 | 135 | – | – | 15 | 481 |
| QST50-200CTV-T50-H19 | 135 | – | – | 15 | 481 |
| QST62-350CTV-H19 | 153 | – | – | 14 | 564 |
| QST62-350CTV-T25-H19 | 153 | – | – | 14 | 564 |
| QST62-600CTV-H25 | 174 | – | – | 14 | 564 |

| Model | A mm | B mm | C mm | D mm | E mm |
|--|---------|---------|---------|---------|---------|
| Extended spring travel 76 mm and 100 mm | | | | | |
| QST42-20CT-T76-L189-H10 | 189 | 23 | 421 | 15 | – |
| QST42-50CT-T76-L189-H13 | 189 | 23 | 447 | 15 | – |
| QST50-90CT-T76-L200-H13 | 200 | 25 | 493 | 15 | – |
| QST50-150CT-T76-L200-H13 | 200 | 25 | 493 | 15 | – |
| QST62-230CT-T76-L200-H19 | 200 | 25 | 543 | 15 | – |
| QST62-350CT-T76-L200-H19 | 200 | 25 | 543 | 15 | – |
| QST80-450CT-T76-L214-H19 | 214 | 43 | 595 | 20 | – |
| QST80-600CT-T76-L214-H19 | 214 | 43 | 595 | 20 | – |
| QST90-750CT-T76-L176-H25 | 176 | 32 | 600 | 20 | – |
| QST90-1000CT-T76-L176-H25 | 176 | 32 | 650 | 20 | – |
| QST42-50CT-T100-L191-H13 | 191 | 23 | 519 | 15 | – |
| QST50-150CT-T100-L186-H13 | 186 | 23 | 563 | 15 | – |
| Dual transducers, CTT | | | | | |
| QST42-20CTT-T50-L134-H10 | 134 | 23 | 395 | 15 | – |
| QST42-20COTT-T50-L134-H10 | 134 | – | – | – | 446 |
| QST42-50CTT-T50-L134-H13 | 134 | 23 | 422 | 15 | – |
| QST42-50COTT-T50-L134-H13 | 134 | – | – | – | 472 |
| QST50-90CTT-T50-L137-H13 | 137 | 23 | 464 | 15 | – |
| QST50-90COTT-T50-L137-H13 | 137 | – | – | – | 521 |
| QST50-150CTT-T50-L137-H13 | 137 | 23 | 464 | 15 | – |
| QST50-150COTT-T50-L137-H13 | 137 | – | – | – | 521 |
| QST62-150CTT-T50-L152-H13 | 152 | 25 | 542 | 15 | – |
| QST62-150COTT-T50-L152-H13 | 137 | – | – | – | 521 |
| QST62-230CTT-T50-L152-H19 | 152 | 25 | 542 | 15 | – |
| QST62-230COTT-T50-L152-H19 | 152.5 | – | – | – | 586 |
| QST62-350CTT-T50-L152-H19 | 152 | 25 | 542 | 15 | – |
| QST62-350COTT-T50-L152-H19 | 152 | – | – | – | 592 |
| QST80-450CTT-T50-L146-H19 | 146 | 30 | 595 | 20 | – |
| QST80-450COTT-T50-L146-H19 | 146 | – | – | – | 685 |
| QST80-600CTT-T50-L146-H19 | 146 | 30 | 595 | 20 | – |
| QST80-600COTT-T50-L146-H19 | 146 | – | – | – | 685 |
| QST90-750CTT-T50-L152-H25 | 146 | 30 | 595 | 20 | – |
| QST90-750COTT-T50-L152-H25 | 103 | – | – | – | 706 |
| QST90-1000CTT-T50-L152-H25 | 152 | 32 | 600 | 20 | – |
| QST90-1000COTT-T50-L152-H25 | 153 | – | – | – | 710 |

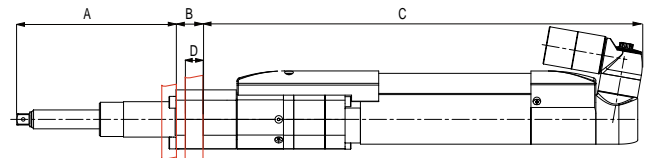

CT – straight version

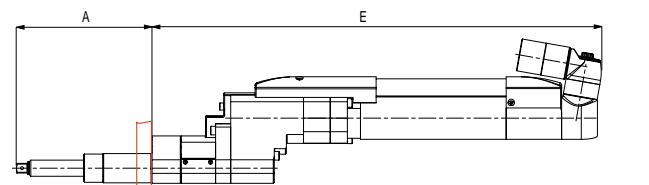

COT – off-set version

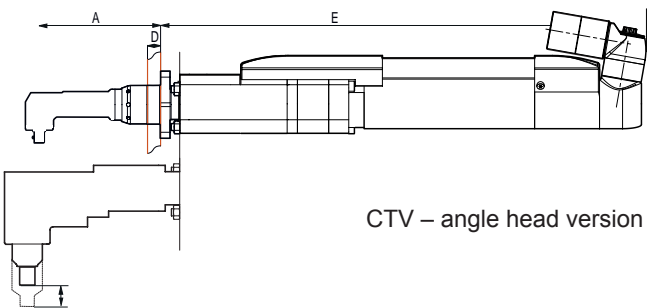

CTV – angle head version

Optional Accessories

TOOL AND EXTENSION CABLES

| Length | Ordering No. |
|--------|--------------|
| 2 m | 4220 3799 02 |
| 3 m | 4220 3799 03 |
| 5 m | 4220 3799 05 |
| 7 m | 4220 3799 07 |
| 10 m | 4220 3799 10 |
| 15 m | 4220 3799 15 |
| 20 m | 4220 3799 20 |
| 25 m | 4220 3799 25 |
| 30 m | 4220 3799 30 |
| 35 m | 4220 3799 35 |
| 40 m | 4220 3799 40 |



Tool and extension cable



Additional socket holder length

ADDITIONAL SOCKET HOLDERS

| | A mm | Product No. | Socket holder size in | Socket holder ^a Ordering No. |
|--------------------|----------------|--------------|--------------------------------|---|
| QST42-20CT | | | | |
| | 0 ^b | 8435 6020 10 | 3/8 | 4230 1818 00 |
| | 50 | 8435 4083 08 | 3/8 | 4230 2217 00 |
| | 100 | 8435 4083 10 | 3/8 | 4230 2217 01 |
| | 150 | 8435 4083 12 | 3/8 | 4230 2217 02 |
| | 200 | 8435 4083 14 | 3/8 | 4230 2217 03 |
| QST42-50CT | | | | |
| | 0 ^b | 8435 6030 10 | 1/2 | 4230 1819 00 |
| | 50 | 8435 4083 19 | 1/2 | 4230 2218 00 |
| | 100 | 8435 4083 21 | 1/2 | 4230 2218 01 |
| | 150 | 8435 4083 23 | 1/2 | 4230 2218 02 |
| | 200 | 8435 4083 25 | 1/2 | 4230 2218 03 |
| QST50-90CT | | | | |
| | 0 ^b | 8435 6040 10 | 1/2 | 4230 1820 00 |
| | 50 | 8435 4083 28 | 1/2 | 4230 2219 00 |
| | 100 | 8435 4083 29 | 1/2 | 4230 2219 01 |
| | 150 | 8435 4083 30 | 1/2 | 4230 2219 02 |
| | 200 | 8435 4083 31 | 1/2 | 4230 2219 03 |
| QST50-150CT | | | | |
| | 0 ^b | 8435 6050 10 | 1/2 | 4230 1820 00 |
| | 50 | 8435 4083 68 | 1/2 | 4230 2219 00 |
| | 100 | 8435 4083 33 | 1/2 | 4230 2219 01 |
| | 150 | 8435 4083 34 | 1/2 | 4230 2219 02 |
| | 200 | 8435 4083 35 | 1/2 | 4230 2219 03 |
| QST62-150CT | | | | |
| | 0 ^b | 8435 6060 10 | 1/2 | 4230 1829 00 |
| | 50 | 8435 4083 37 | 1/2 | 4230 2223 00 |
| | 100 | 8435 4083 40 | 1/2 | 4230 2223 01 |
| | 150 | 8435 4083 43 | 1/2 | 4230 2223 02 |
| | 200 | 8435 4083 46 | 1/2 | 4230 2223 03 |
| | 0 | 8435 4083 70 | 5/8 | 4230 1821 00 |
| | 50 | 8435 4083 38 | 5/8 | 4230 2224 00 |
| | 100 | 8435 4083 41 | 5/8 | 4230 2224 01 |
| | 150 | 8435 4083 44 | 5/8 | 4230 2224 02 |
| | 200 | 8435 4083 47 | 5/8 | 4230 2224 03 |

| | A mm | Product No. | Socket holder size in | Socket holder ^a Ordering No. |
|--------------------|----------------|--------------|--------------------------------|---|
| QST62-230CT | | | | |
| | 0 | 8435 4083 81 | 5/8 | 4230 1821 00 |
| | 50 | 8435 4083 83 | 5/8 | 4230 2224 00 |
| | 100 | 8435 4083 98 | 5/8 | 4230 2224 01 |
| | 150 | 8435 4083 88 | 5/8 | 4230 2224 02 |
| | 200 | 8435 4083 91 | 5/8 | 4230 2224 03 |
| | 0 ^b | 8435 5170 10 | 3/4 | 4230 1822 00 |
| | 50 | 8435 4083 84 | 3/4 | 4230 2226 00 |
| | 100 | 8435 4083 86 | 3/4 | 4230 2226 01 |
| | 150 | 8435 4083 89 | 3/4 | 4230 2226 02 |
| | 200 | 8435 4083 92 | 3/4 | 4230 2226 03 |
| QST62-350CT | | | | |
| | 0 | 8435 4083 72 | 5/8 | 4230 1821 00 |
| | 50 | 8435 4083 53 | 5/8 | 4230 2224 00 |
| | 100 | 8435 4083 56 | 5/8 | 4230 2224 01 |
| | 150 | 8435 4083 59 | 5/8 | 4230 2224 02 |
| | 200 | 8435 4083 62 | 5/8 | 4230 2224 03 |
| | 0 ^b | 8435 6070 10 | 3/4 | 4230 1822 00 |
| | 50 | 8435 4083 54 | 3/4 | 4230 2226 00 |
| | 100 | 8435 4083 57 | 3/4 | 4230 2226 01 |
| | 150 | 8435 4083 60 | 3/4 | 4230 2226 02 |
| | 200 | 8435 4083 63 | 3/4 | 4230 2226 03 |

^a This socket holder is included when you order the complete spindle.

^b This socket holder follows when you order the standard nutrunner.

NOTE: The spindle travel is 50 mm for all sockets holders.

- Inline nutrunner, CT – Equipped with commutation sensor and transducer.
- Off-set nutrunner, COT – Comes with a commutation sensor, off-set gears for narrow bolts and transducer.
- Extended spring travel 76 mm and 100 mm – Nutrunners with extended spring travel for longer bolt lengths.
- Angle head nutrunners, CTV – Nutrunners with angle heads. Available with or without travel.
- Yield control is available for ETX.

ETX42-20COT

ETX50-90CT



| Model | Travel mm | Torque range | | Speed r/min | Min C-C | Weight | | Gear ratio | Socket holder size in | Ordering No. |
|-------------------------|--------------|--------------|---------|----------------|------------|--------|------|---------------|--------------------------------|--------------|
| | | Nm | ft lb | | | kg | lb | | | |
| ETX42-20CT | 50 | 6-20 | 4-14 | 2000 | 43 | 3.2 | 7.1 | 7.50 | 3/8 | 8435 5120 10 |
| ETX42-20COT | 50 | 6-20 | 4-14 | 2000 | 31 | 4.3 | 9.5 | 7.50 | 3/8 | 8435 5120 20 |
| ETX42-50CT | 50 | 10-50 | 7-35 | 700 | 43 | 3.5 | 7.7 | 21.33 | 1/2 | 8435 5130 10 |
| ETX42-50COT | 50 | 10-50 | 7-35 | 700 | 31 | 4.6 | 10.1 | 21.33 | 1/2 | 8435 5130 20 |
| ETX50-90CT | 50 | 20-90 | 15-65 | 650 | 51 | 5.9 | 13.0 | 18.21 | 1/2 | 8435 5140 10 |
| ETX50-90COT | 50 | 20-90 | 15-65 | 650 | 37 | 8.1 | 17.9 | 18.21 | 1/2 | 8435 5140 20 |
| ETX50-150CT | 50 | 30-150 | 22-110 | 380 | 51 | 5.8 | 12.8 | 31.24 | 1/2 | 8435 5150 10 |
| ETX50-150COT | 50 | 30-150 | 22-110 | 380 | 37 | 8.0 | 17.6 | 31.24 | 1/2 | 8435 5150 20 |
| ETX62-150CT | 50 | 30-150 | 22-110 | 450 | 63 | 9.5 | 20.9 | 13.94 | 1/2 | 8435 5160 10 |
| ETX62-150COT | 50 | 30-150 | 22-110 | 450 | 46 | 9.5 | 20.9 | 13.94 | 1/2 | 8435 5160 20 |
| ETX62-230CT | 50 | 40-230 | 29-170 | 330 | 63 | 10.2 | 22.5 | 19.04 | 3/4 | 8435 5170 10 |
| ETX62-230COT | 50 | 40-220 | 29-162 | 330 | 46 | 12.8 | 28.2 | 19.04 | 3/4 | 8435 5170 20 |
| ETX62-350CT | 50 | 50-350 | 37-258 | 220 | 63 | 10.2 | 22.5 | 28.33 | 3/4 | 8435 5180 10 |
| ETX62-350COT | 50 | 50-330 | 37-243 | 220 | 50 | 12.9 | 28.4 | 28.33 | 3/4 | 8435 5180 20 |
| ETX72-450CT | 50 | 90-450 | 65-331 | 160 | 73 | 11.3 | 25 | 41.6 | 3/4 | 8435 5182 10 |
| ETX72-600CT | 50 | 120-600 | 90-441 | 110 | 73 | 11.3 | 25 | 58.0 | 3/4 | 8435 5183 10 |
| ETX72-600COT | 50 | 120-580 | 90-425 | 110 | 55 | 17 | 37.5 | 57.99 | 3/4 | 8435 5183 20 |
| ETX90-750CT | 50 | 150-750 | 110-551 | 90 | 91 | 17.8 | 39 | 68.3 | 1 | 8435 5184 10 |
| ETX90-950CT | 50 | 200-950 | 150-699 | 70 | 91 | 17.8 | 39 | 90.0 | 1 | 8435 5185 10 |
| Angle head tools | | | | | | | | | | |
| ETX42-70CTV | - | 15-70 | 11-50 | 355 | 45 | 4.9 | 10.8 | 21.33 | 1/2 | 8435 4072 07 |
| ETX50-170CTV | - | 22-170 | 16-125 | 200 | 50 | 9.1 | 20 | 31.24 | 1/2 | 8435 4073 04 |
| ETX62-350CTV | - | 50-350 | 37-221 | 175 | 70 | 13.9 | 28.9 | 19.04 | 3/4 | 8435 4074 72 |

Dimensions

| Model | L mm | B mm | C mm | D mm | E mm |
|--------------|---------|---------|---------|---------|---------|
| ETX42-20CT | 134 | 23 | 363 | 15 | - |
| ETX42-20COT | 134 | - | - | - | 436 |
| ETX42-50CT | 134 | 23 | 389 | 15 | - |
| ETX42-50COT | 134 | - | - | - | 463 |
| ETX50-90CT | 137 | 23 | 439 | 15 | - |
| ETX50-90COT | 137 | - | - | - | 519 |
| ETX50-150CT | 137 | 23 | 439 | 15 | - |
| ETX50-150COT | 137 | - | - | - | 519 |
| ETX62-150CT | 152 | 25 | 506 | 15 | - |
| ETX62-150COT | 153 | - | - | - | 575 |
| ETX62-230CT | 152 | 25 | 506 | 15 | - |
| ETX62-230COT | 152 | - | - | - | 575 |
| ETX62-350CT | 152 | 25 | 506 | 15 | - |
| ETX62-350COT | 152 | - | - | - | 580 |
| ETX72-450CT | 146 | 30 | 580 | 20 | - |
| ETX72-600CT | 146 | 30 | 580 | 20 | - |
| ETX72-600COT | 146 | - | - | - | 672 |
| ETX90-750CT | 152 | 32 | 550 | 20 | - |
| ETX90-950CT | 152 | 32 | 550 | 20 | - |
| ETX42-70CTV | 85 | - | - | 15 | 422 |
| ETX50-170CTV | 133 | - | - | 15 | 479 |
| ETX62-350CTV | 153 | - | - | 15 | 553 |

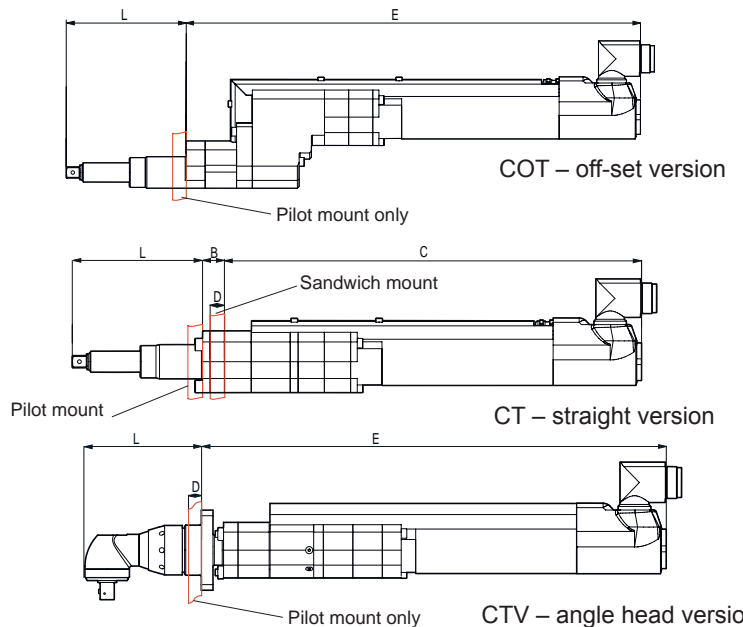

Optional Accessories

CABLES

| Model | Ordering No. |
|-------------------------|--------------|
| Tool cables | |
| 2 m | 4230 2195 02 |
| 5 m | 4230 2195 05 |
| 7 m | 4230 2195 07 |
| 10 m | 4230 2195 10 |
| 15 m | 4230 2195 15 |
| 20 m | 4230 2195 20 |
| Extension cables | |
| 5 m | 4220 1563 05 |
| 10 m | 4220 1563 10 |
| 15 m | 4220 1563 15 |

RBU

| Model | Ordering No. |
|----------|--------------|
| RBU-X | 8433 0080 20 |
| RBU-Gold | 8433 0020 20 |



RBU-X



RBU-Gold

Additional socket holder length



ADDITIONAL SOCKET HOLDERS

| | A mm | Product No. | Socket holder size in | Socket holder ^a Ordering No. |
|--------------------|----------------|--------------|--------------------------------|---|
| ETX42-20CT | 0 ^b | 8435 5120 10 | 3/8 | 4230 1818 00 |
| | 50 | 8435 4063 08 | 3/8 | 4230 2217 00 |
| | 100 | 8435 4063 10 | 3/8 | 4230 2217 01 |
| | 150 | 8435 4063 12 | 3/8 | 4230 2217 02 |
| | 200 | 8435 4063 14 | 3/8 | 4230 2217 03 |
| ETX42-50CT | 0 ^b | 8435 5130 10 | 1/2 | 4230 1819 00 |
| | 50 | 8435 4063 19 | 1/2 | 4230 2218 00 |
| | 100 | 8435 4063 21 | 1/2 | 4230 2218 01 |
| | 150 | 8435 4063 23 | 1/2 | 4230 2218 02 |
| | 200 | 8435 4063 25 | 1/2 | 4230 2218 03 |
| ETX50-90CT | 0 ^b | 8435 5140 10 | 1/2 | 4230 1820 00 |
| | 50 | 8435 4063 28 | 1/2 | 4230 2219 00 |
| | 100 | 8435 4063 29 | 1/2 | 4230 2219 01 |
| | 150 | 8435 4063 30 | 1/2 | 4230 2219 02 |
| | 200 | 8435 4063 31 | 1/2 | 4230 2219 03 |
| ETX50-150CT | 0 ^b | 8435 5150 10 | 1/2 | 4230 1820 00 |
| | 50 | 8435 4063 68 | 1/2 | 4230 2219 00 |
| | 100 | 8435 4063 33 | 1/2 | 4230 2219 01 |
| | 150 | 8435 4063 34 | 1/2 | 4230 2219 02 |
| | 200 | 8435 4063 35 | 1/2 | 4230 2219 03 |
| ETX62-150CT | 0 ^b | 8435 5160 10 | 1/2 | 4230 1829 00 |
| | 50 | 8435 4063 37 | 1/2 | 4230 2223 00 |
| | 100 | 8435 4063 40 | 1/2 | 4230 2223 01 |
| | 150 | 8435 4063 43 | 1/2 | 4230 2223 02 |
| | 200 | 8435 4063 46 | 1/2 | 4230 2223 03 |
| | 0 | 8435 4063 70 | 5/8 | 4230 1821 00 |
| | 50 | 8435 4063 38 | 5/8 | 4230 2224 00 |
| | 100 | 8435 4063 41 | 5/8 | 4230 2224 01 |
| | 150 | 8435 4063 44 | 5/8 | 4230 2224 02 |
| | 200 | 8435 4063 47 | 5/8 | 4230 2224 03 |

| | A mm | Product No. | Socket holder size in | Socket holder ^a Ordering No. |
|--------------------|----------------|--------------|--------------------------------|---|
| ETX62-230CT | 0 | 8435 4063 81 | 5/8 | 4230 1821 00 |
| | 50 | 8435 4063 83 | 5/8 | 4230 2224 00 |
| | 100 | 8435 4063 98 | 5/8 | 4230 2224 01 |
| | 150 | 8435 4063 88 | 5/8 | 4230 2224 02 |
| | 200 | 8435 4063 91 | 5/8 | 4230 2224 03 |
| | 0 ^b | 8435 5170 10 | 3/4 | 4230 1822 00 |
| | 50 | 8435 4063 84 | 3/4 | 4230 2226 00 |
| | 100 | 8435 4063 86 | 3/4 | 4230 2226 01 |
| | 150 | 8435 4063 89 | 3/4 | 4230 2226 02 |
| | 200 | 8435 4063 92 | 3/4 | 4230 2226 03 |
| ETX62-350CT | 0 | 8435 4063 72 | 5/8 | 4230 1821 00 |
| | 50 | 8435 4063 53 | 5/8 | 4230 2224 00 |
| | 100 | 8435 4063 56 | 5/8 | 4230 2224 01 |
| | 150 | 8435 4063 59 | 5/8 | 4230 2224 02 |
| | 200 | 8435 4063 62 | 5/8 | 4230 2224 03 |
| | 0 ^b | 8435 5180 10 | 3/4 | 4230 1822 00 |
| | 50 | 8435 4063 54 | 3/4 | 4230 2226 00 |
| | 100 | 8435 4063 57 | 3/4 | 4230 2226 01 |
| | 150 | 8435 4063 60 | 3/4 | 4230 2226 02 |
| | 200 | 8435 4063 63 | 3/4 | 4230 2226 03 |

^a This socket holder is included when you order the complete nutrunner.

^b This socket holder follows when you order the standard nutrunner.

NOTE: The spindle travel is 50 mm for all sockets holders.

Advanced process control and monitoring

State-of-the-art tightening controllers PowerMACS 4000 and Power Focus with their advanced process control and monitoring functions, and supported by ToolsTalk software, can put your assembly operation on the path to zero-fault production.

POWERMACS 4000

PowerMACS 4000 is Atlas Copco's latest, most advanced tightening controller for fixtured tools. It has effective tools for statistical process control to ensure that quality issues are identified long before they cause production problems.

The controller supports a zero-fault production philosophy with its capacity to collect tightening data for analysis, continuous improvement and traceability. Power MACS processing power and memory are designed to handle and send large amounts of data without influencing the tightening process.

POWER FOCUS

Power Focus is a modular range of controllers, with full flexibility, designed for applications ranging from single nut-runner hand-held operations to fixtured multiple nutrunning systems. Advanced process control and monitoring functions make it easy to view and collect data using the Internet infrastructure.

The Power Focus 4000 is available in two versions, Compact and Graph. The difference between them is the user interface, where the Graph features the color display and a full keyboard.

TOOLSTALK POWERMACS

The ToolsTalk software for PowerMACS 4000 has been developed with user friendliness and customer adaptation in mind and can be installed on a laptop or a back office PC.



POWERMACS 4000

One primary controller is needed per system. The primary controller takes care of external communication and comes with most field busses used in modern production lines (optional). A primary controller can be run as a secondary controller.

The secondary controller comes in two versions; with or without Ethernet switch in the back plate.

- One servo covers the complete torque range from 2 to 8,000 Nm.
- No external PC required, inherent back-up functionality for increased reliability.
- Define your tightening strategy based on results to make sure valuable time and resources are not wasted.
- Powerful PLC onboard.
- Reject Management enabling you to handle faulty tightening in the most efficient way.
- Extensive library of tested tightening strategies – each joint can be tightened in the best possible way in terms of cycle time and quality.
- Stand alone design (no need for bulky cabinets).
- 24V DC supply, integrated Ethernet switch, E-stop circuit.
- Informative display
- Integrated line filter.



TC-P



TC-S

POWERMACS 4000 CONTROLLERS

| Model | Fieldbus version | Ordering No. |
|-----------------------------|---------------------------------|--------------|
| Primary controller | | |
| TC-4000-P-ES | No Fieldbus | 8435 6511 00 |
| TC-4000-P-PB-ES | Profibus | 8435 6511 10 |
| TC-4000-P-DN-ES | DeviceNet | 8435 6511 30 |
| TC-4000-P-EIP-ES | Ethernet IP | 8435 6511 60 |
| TC-4000-P-MTCP-ES | ModBus TCP | 8435 6511 70 |
| TC-4000-P-PN-ES | Profi Net | 8435 6511 50 |
| TC-4000-P-CC-ES | CC link | 8435 6511 80 |
| Secondary controller | | |
| TC-4000-S | No fieldbus, No Ethernet switch | 8435 6500 00 |
| TC-4000-S-ES | No fieldbus, Ethernet switch | 8435 6501 00 |

MAIN SWITCH BOX – MSB

The MSB is used for power distribution and makes power management easy. It is designed be fed with 380-480 V AC 3-phase without requiring an external transformer. The MSB leaves room for customer adaptations and the E-stop functionality can be upgraded from class 3 to class 4. Each MSB supplies up to 6 controllers with power.

MAIN SWITCH BOX II – MSB II

Main Switch Box II exists in two versions, 30 Amps and 60 Amps.

DISTRIBUTION BOX – DB

The DB provides the same functionality as the MSB except for the main switch and is used as a complement to the MSB for systems with more than 6 channels.

DISTRIBUTION BOX II – DB II

DB II is needed when MSB II is used.

GENERAL BOX – GB

An empty DB, suitable for external system devices.



| Model | Ordering No. |
|---|--------------|
| MSB | |
| Main switch box (Max 6 channels) | 8435 5660 00 |
| Main switch box II, 30 amps (Max 6 channels) | 8435 5660 30 |
| Main switch box II, 60 amps (Max 6 channels) | 8435 5660 60 |
| DB | |
| Distribution box (Max 6 channels) + Power cable 1800 mm | 8435 6560 50 |
| Distribution box II | 8435 5660 10 |
| GB | |
| General box | 4222 1249 85 |

EASY-TO-BUILD SYSTEM

| | | | |
|--|--------------|----------------|--------------|
| Power cables | 4222 1248 xx | Ethernet cable | 4222 1246 xx |
| E-Stop cable | 4222 1247 xx | Motor cable | 4220 3799 xx |

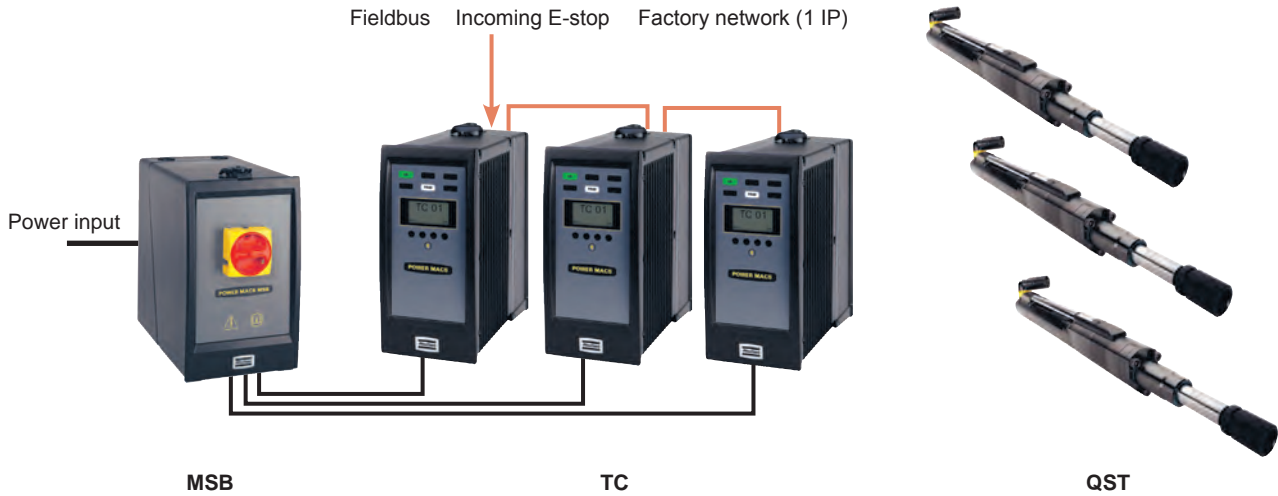

With the PowerMACS 4000 controller, multiple-spindle systems are easy to configure. Simply refer to the system ordering table to see which components you need.

SYSTEM ORDERING TABLE FOR A SYSTEM WITH ONE STATION

| No. of spindles | Number of | | | | | tool cables | System cable kit ^a | No. of spindles | Number of | | | | | tool cables | System cable kit ^a |
|-----------------|-----------|------|-----|----|--|-------------|-------------------------------|-----------------|-----------|------|-----|----|----|-------------|-------------------------------|
| | TC-P | TC-S | MSB | DB | | | | | TC-P | TC-S | MSB | DB | | | |
| 1 | 1 | 0 | 1 | 0 | | 1 | 1 | 10 | 1 | 9 | 1 | 1 | 10 | 1 | |
| 2 | 1 | 1 | 1 | 0 | | 2 | 1 | 11 | 1 | 10 | 1 | 1 | 11 | 1 | |
| 3 | 1 | 2 | 1 | 0 | | 3 | 1 | 12 | 1 | 11 | 1 | 1 | 12 | 1 | |
| 4 | 1 | 3 | 1 | 0 | | 4 | 1 | 13 | 1 | 12 | 1 | 2 | 13 | 1 | |
| 5 | 1 | 4 | 1 | 0 | | 5 | 1 | 14 | 1 | 13 | 1 | 2 | 14 | 1 | |
| 6 | 1 | 5 | 1 | 0 | | 6 | 1 | 15 | 1 | 14 | 1 | 2 | 15 | 1 | |
| 7 | 1 | 6 | 1 | 1 | | 7 | 1 | 16 | 1 | 15 | 1 | 2 | 16 | 1 | |
| 8 | 1 | 7 | 1 | 1 | | 8 | 1 | 17 | 1 | 16 | 1 | 2 | 17 | 1 | |
| 9 | 1 | 8 | 1 | 1 | | 9 | 1 | 18 | 1 | 17 | 1 | 2 | 18 | 1 | |

^a See system cable kits below.

SYSTEM CABLE KIT

| No. of spindles | Power cable | | | Ethernet cable | | | E-stop cable | | Ethernet switch incl. Backplate 4222 0982 90 | Ordering No. ^b |
|-----------------|-------------------------|-------------------------|-------------------------|---------------------|---------------------|---------------------|-------------------------|-------------------------|---|---------------------------|
| | 1350 mm 4222 1248 13 | 1650 mm 4222 1248 16 | 1950 mm 4222 1248 19 | 1 m 4222 1246 01 | 2 m 4222 1246 02 | 3 m 4222 1246 03 | 1200 mm 4222 1247 12 | 3000 mm 4222 1247 30 | | |
| 1 | 1 | - | - | - | - | - | - | - | - | 8435 6560 01 |
| 2 | 2 | - | - | 1 | - | - | 1 | - | - | 8435 6560 02 |
| 3 | 2 | 1 | - | 1 | 1 | - | 1 | 1 | - | 8435 6560 03 |
| 4 | 2 | 2 | - | 1 | 2 | - | 2 | 1 | - | 8435 6560 04 |
| 5 | 2 | 2 | 1 | 1 | 3 | - | 3 | 1 | - | 8435 6560 05 |
| 6 | 2 | 2 | 2 | 4 | 1 | - | 4 | 1 | 1 | 8435 6560 06 |
| 7 | 4 | 3 | - | 5 | 1 | - | 5 | 1 | 1 | 8435 6560 07 |
| 8 | 4 | 4 | - | 6 | 1 | - | 6 | 1 | 1 | 8435 6560 08 |
| 9 | 4 | 3 | 2 | 4 | 1 | 3 | 7 | 1 | 1 | 8435 6560 09 |
| 10 | 4 | 4 | 2 | 5 | 1 | 3 | 8 | 1 | 2 | 8435 6560 10 |
| 11 | 4 | 4 | 3 | 6 | 1 | 3 | 9 | 1 | 2 | 8435 6560 11 |
| 12 | 4 | 4 | 4 | 7 | 1 | 3 | 10 | 1 | 2 | 8435 6560 12 |
| 13 | 5 | 4 | 4 | 7 | 1 | 4 | 10 | 2 | 2 | 8435 6560 13 |
| 14 | 6 | 4 | 4 | 8 | 1 | 4 | 11 | 2 | 3 | 8435 6560 14 |
| 15 | 6 | 5 | 4 | 9 | 1 | 4 | 12 | 2 | 3 | 8435 6560 15 |
| 16 | 6 | 6 | 4 | 10 | 1 | 4 | 13 | 2 | 3 | 8435 6560 16 |
| 17 | 6 | 6 | 5 | 10 | 2 | 4 | 14 | 2 | 3 | 8435 6560 17 |
| 18 | 6 | 6 | 6 | 11 | 2 | 4 | 15 | 2 | 4 | 8435 6560 18 |

^b Based on Atlas Copco suggested set-up.

Optional Accessories

ETHERNET CABLES

| Length | Ordering No. |
|--------|--------------|
| 0.5 m | 4222 1246 00 |
| 1 m | 4222 1246 01 |
| 2 m | 4222 1246 02 |
| 3 m | 4222 1246 03 |
| 5 m | 4222 1246 05 |
| 10 m | 4222 1246 10 |
| 15 m | 4222 1246 15 |



Ethernet cable

E-STOP CABLES AND TERMINATION

| Components | Length | Ordering No. |
|--------------------|---------|--------------|
| E-stop cable | 1200 mm | 4222 1247 12 |
| E-stop cable | 3000 mm | 4222 1247 30 |
| E-stop termination | | 4222 0755 00 |



E-stop cable

POWER CABLES BETWEEN MSB AND TC

| Suitable for | Length | Ordering No. |
|-------------------------------|---------|--------------|
| TC1-TC2, TC7-TC8, TC13-TC14 | 1350 mm | 4222 1248 13 |
| TC3-TC4, TC9-TC10, TC15-TC16 | 1650 mm | 4222 1248 16 |
| TC5-TC6, TC11-TC12, TC17-TC18 | 1950 mm | 4222 1248 19 |
| For longer distances | 5 m | 4222 1248 50 |
| | 10 m | 4222 1370 10 |
| | 15 m | 4222 1370 15 |
| | 20 m | 4222 1370 20 |



Power cable between MSB and TC

INDICATOR BOX AND CABLE

| Model | Ordering No. | |
|----------------------------------|--------------|--------------|
| Indicator box | 8435 3010 04 | |
| Indicator box cable to PM4K, 1 m | 4243 0278 80 | |
| Open end cable 5 m | 4243 0281 05 | |
| Extension cable | 3 m | 4243 0282 03 |
| | 5 m | 4243 0282 05 |
| | 10 m | 4243 0282 10 |
| | 15 m | 4243 0282 15 |
| | 20 m | 4243 0282 20 |
| 25 m | 4243 0282 25 | |



Indicator box

OPERATOR HANDLE

| Model | Ordering No. |
|-------------------------------------|--------------|
| Operator handle (ball joint/handle) | |
| - front/plastic | 8435 3030 00 |
| - front/rubber | 8435 3030 01 |
| - rear/plastic | 8435 3030 02 |
| - rear/rubber | 8435 3030 03 |



Operator handle

ADVANCED PROCESS CONTROL AND MONITORING FUNCTIONS

Power Focus is a modular range of controllers, with full flexibility, designed for applications ranging from single spindle hand-held operations to fixtured multiple nutrunning systems. Advanced process control and monitoring functions make it easy to view and collect data using the Ethernet infrastructure.

- Choose your controller – either Graph or Compact.
- Choose your RBU software key to run a tool.
- Choose from various ways to use the controller, as a stand-alone or in a network.
- Run many different kinds of tool, standard, FS, crowfoot or open tools.
- Realtime statistics analysis.
- Error-proofing solution.
- Advanced tightening control and/or monitoring method.
- Trace view.
- Logic configurator.
- Can handle different levels of communication.

The Power Focus 4000 is available in two versions, Compact and Graph. The difference between them is the user interface, where the Graph features the color display and a full keyboard.

COMPACT

This version offers full functionality at a lower cost, but requires a PC with the ToolsTalk PF software for process set-up.

GRAPH

With the Graph hardware, you have full stand-alone programming possibilities. When networked, the Graph can function as a programming terminal for other Power Focus units.

RBU CUTS DOWNTIME

Atlas Copco's patented Rapid Backup Unit (RBU) concept transfers functionality to a non-configured hardware unit, ensuring that hardware can easily be upgraded should functionality requirements change. The RBU also acts as back-up for programming and configuration. If a change of hardware is required, just fit the RBU to the new hardware, switch on the unit and you're ready. All programming and network configurations are transferred in seconds. The RBU cuts downtime to a minimum.



Compact



Graph

POWER FOCUS 4000 AND ETX

| Model | Ordering No. |
|------------------------------|--------------|
| Power Focus 4000 W 10 | |
| PF 4000-G-HW | 8433 7100 00 |
| PF 4000-C-HW | 8433 7100 05 |
| PF 4000-G-DN- HW | 8433 7140 00 |
| PF 4000-C-DN-HW | 8433 7140 05 |
| PF 4000-G-PB-HW | 8433 7142 00 |
| PF 4000-C-PB-HW | 8433 7142 05 |
| PF 4000-G-CC-HW | 8433 7143 00 |
| PF 4000-C-CC-HW | 8433 7143 05 |
| PF 4000-G-PN-HW | 8433 7148 00 |
| PF 4000-C-PN-HW | 8433 7148 05 |
| PF 4000-G-EIP-HW | 8433 7149 00 |
| PF 4000-C-EIP-HW | 8433 7149 05 |

CONTROLLER FUNCTIONALITY

| Hardware key | Ordering No. |
|--------------|--------------|
| RBU-Gold | 8433 0020 20 |
| RBU-X | 8433 0080 20 |

TOOLSTALK POWERMACS

The ToolsTalk software for PowerMACS 4000 has been developed with user friendliness and customer adaptation in mind. This Window-based program can be installed on a station PC, a laptop or a back office PC. ToolsTalk supports off-line programming; to edit or upload programs, simply connect the PC to the PowerMACS 4000 controller using an Ethernet cable.

- User friendly Windows programming interface with “drag-and-drop” and “copy-paste” functionalities.
- 10 levels of read and write security.
- Trace reporting on torque, angle, current, current as torque and time.
- Improved read-at-a-glance graphics with actual pictures of customer parts.
- Possible to view up to 20 tightening traces simultaneously.
- Graphical system map of hardware and software.
- Configurable cycle data menu for station reporting.
- Real time SPC and TDA reporting.
- Event logging of security access, parameter changes, errors, faults, alarms and warnings.
- Maintenance menus to verify hardware and software changes without machine intervention.
- Run the program in Basic or Advanced mode depending on needs.
- Quick-set functionality for trimming a process in seconds.
- Optimize each tightening by means of the tightening path for each bolt, including start times, stop times, and execution times for the steps.

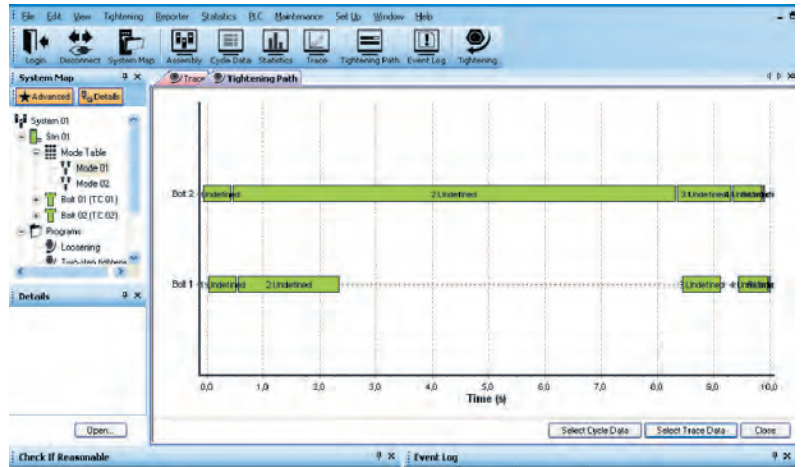

TOOLSTALK POWER MACS WORLD RELEASE 10

| | Designation | Ordering No. |
|---------------|-------------|--------------|
| 1 user | English | 8092 1308 01 |
| 5 user | English | 8092 1308 05 |
| 10 user | English | 8092 1308 10 |
| Plant license | English | 8092 1308 97 |
| 1 user | German | 8092 1308 11 |
| 5 user | German | 8092 1308 15 |
| 10 user | German | 8092 1308 20 |
| Plant license | German | 8092 1308 98 |
| 1 user | French | 8092 1308 21 |
| 5 user | French | 8092 1308 25 |
| 10 user | French | 8092 1308 30 |
| Plant license | French | 8092 1308 99 |

TOOLSTALK POWER MACS WORLD RELEASE 10 GAUGING

| | Designation | Ordering No. |
|---------------|-------------|--------------|
| 1 user | English | 8092 1309 01 |
| 5 user | English | 8092 1309 05 |
| 10 user | English | 8092 1309 10 |
| Plant license | English | 8092 1309 97 |
| 1 user | German | 8092 1309 11 |
| 5 user | German | 8092 1309 15 |
| 10 user | German | 8092 1309 20 |
| Plant license | German | 8092 1309 98 |
| 1 user | French | 8092 1309 21 |
| 5 user | French | 8092 1309 25 |
| 10 user | French | 8092 1309 30 |
| Plant license | French | 8092 1309 99 |

QUALITY ASSURANCE AND MANUAL FASTENING

Contents

| | |
|-----------------------------|-----|
| STa 6000 analyser..... | 192 |
| SRTT-L transducers..... | 195 |
| QRTT transducers | 196 |
| IRTT-B transducers | 196 |
| SRTT-B transducers | 197 |
| MRTT-B transducers | 198 |
| MRTT-C transducers | 199 |
| ACTA MT transducers | 200 |
| Mechanical wrenches..... | 202 |
| STwrench..... | 212 |
| Test benches | 218 |
| BLM Torque Supervisor | 221 |



Quality assurance that gives peace of mind

Problems related to tightening account for a growing percentage of total warranty costs. A loose or improperly tightened joint in any assembly operation can cause serious problems and have serious consequences for end-users and result in damaged brand image for the manufacturer. Atlas Copco has developed a comprehensive quality assurance system designed to eliminate these problems.

Atlas Copco's tightening quality assurance system meets torque, angle and pulse measurement requirements for all types of fastening tools and joint verification through the residual torque check process.

In this range there are products that enable you to:

- Test the tool capability in the crib or along the line.
- Calibrate the tool in the fastest, most convenient way.
- Perform statistical process control of the performance of the tool along the line to prevent possible tool errors.
- Check the residual torque in an already tightened joint with an advanced algorithm to avoid operator errors and influence.

DATA ANALYSER PLUS ROTARY AND STATIC TRANSDUCER

The STa 6000 provides a complete range of systems for checking the tool in the tool crib or along the line. When connected with the MRTT-C wrench the STa 6000 is able to detect the residual torque on an already tightened joint using our patented algorithm used also in the STwrench.

STWRENCH

State-of-the-art, four-patent wrench that employs the modularity concept to check the residual torque on an already tightened joint. It can also be used to tighten a bolt with the most advanced torque or torque/angle strategies with complete traceability and error-proofing functionalities.



BENCHES

A full range of Joint Simulator Benches with a patented system for testing tools in real production conditions, or Static transducer benches as an all-in-one mobile system.

SOFTWARE

Torque Supervisor is Quality Management software to manage your Tool/Joint test and your maintenance activity. It can be used with benches, wrenches and data analyser.

NOTE: The accuracy of SRTT-B, IRTT-B, QRTT-B and smartHEAD transducers is 0.5 % of the readout ± 1 digit for the torque range indicated in the tables.

STa 6000

In assembly operations worldwide there is an increasing focus on quality. Using sophisticated tools to tighten bolts is simply not enough. It's also important to monitor tool performance, and to test joints after they have been tightened. This is where the Atlas Copco STa 6000 come in. The portable STa 6000 can be used to check tool performance, repeatability and accuracy for all types of power tools and torque wrenches. Test your tools in the tool crib following service and continuously on the line to monitor performance or test your joint by checking the residual torque using our unique residual torque check function.



STa 6000

Improve everyday tasks for Quality supervisors and operators. Reduced weight and compact design makes the STa 6000 easy to carry along the line. Checking tools in the Tool Crib and on the line and checking tightened joints means quality guaranteed.

PORTABLE AND ERGONOMIC

The compact STa 6000 with long-life battery weighs less than 500 g. No special device is required to carry the system it can be conveniently hung on a strap from the operator's belt.

The STa 6000 small size and features make it easy to use in the production line.

QUICK PROGRAMMING

The STa 6000 is designed for easy connection to Atlas Copco IRTT-B in-line transducers, SRTT-B static transducers and MRTT-C wrenches. It is also easy to connect the STa 6000 to SRTT-L by specific cradle in order to have a compact complete solution.

It provides automatic recognition and calibration and allows the operator to start a test with a few clicks: just selecting the tool type to be checked. The test setup is automatically created by STa 6000.

MODULARITY – YOU BUY WHAT YOU NEED

The STa 6000 is easy to upgrade. You don't need to buy a complete new model. Simply add modules and accessories that expand the functionalities and create your customized torque analyzer system.

COMMONALITY CUTS COSTS

The STa 6000 utilizes the same modules and software as the STanalyser and STwrench, thus saving you money.

CLEAR OPERATOR FEEDBACK

STa 6000 color screen features intuitive icon menus.

Feedback is clearly displayed thanks to the green or red screen, with the possibility to add a gauge indicator and fully customize information.

STa 6000 BASIC

The ideal solution for simple and quick tests.

Quick programming

- The quick tool or joint check test can be launched with STa 6000 basic version. Up to 50000 results are stored in the device memory, traces can be seen with TT BLM if the software is purchased.

- No PC is required
- Test conditions can be set up right on the device for each test
- Color screen
- The green/red color screen guides the operator for the tests

STa 6000 QC

The ideal solution for operators requiring a complete testing solution.

This version includes all the features listed for the Basic one, and additional others:

• Tools and Psets database

This is a list of tools you want to test (max. 1,000). It contains all information related to the tool, such as type, model, min. and max. torque, etc. The PSet defines how the test has to be performed with acceptance limits. A maximum of 1,000 PSets can be stored and 5 max. per tool can be assigned.

• Traces on display

Traces can be seen directly on the STa 6000 screen.

• Customized screen

The measure screen can be customized with all the important information to have them displayed during the test. It is possible to have on the measure screen information as Cm/Cmk values, sigma, last results also a graphical gauge indicator can be added.

- **Full text notes**

Text notes can be added to the results to keep the full traceability of the tests.

- **PF and PM Calibration**

STa 6000 allows to complete calibrations simply connect the STa 6000 to an Atlas Copco controller with either a Ethernet cable or with the small USB to serial adapter. All other operations are done by the STa 6000 as the Pset is automatically read from the controller. The readings are also acquired and the new calibration value is stored in the controller. Calibration made easy, fast and completely error-proofed.

- Reports can be printed on a network printer.

STa 6000 AA

The recommended solution for Advanced Analysis.

- **The STa 6000 ultimate solution**

All the features are included in this version, statistics CM/Cmk graphs and X/R charts can be visualized right on the STa 6000 screen.

TT BLM

With TT BLM software, it's possible to manage programs, settings, results and traces of the STa 6000 remotely via the network from the office PC.

A smart Excel database for the STa 6000 results is featured by TT BLM software.

NOTE: software license is necessary for the above features

TORQUE SUPERVISOR

STa 6000 is fully integrated with Torque Supervisor software.

It's possible to take advantage of all the advanced features of Atlas Copco Quality data management software with STa 6000, programming the tool check and joint check routes to be executed.

ACCESSORIES

With the Barcode Module it is possible to automatically start a tool or a joint test, and it is possible store further scanned information on their results. In addition a work order can be defined to set the scanning order of different identifiers.

With IRC-W Radio Module you can wirelessly communicate to software.

With the USB/Serial converter, it is possible to synchronize to Power Focus, Power MACS and PST for their calibration.

STa 6000

| Model | Ordering No. |
|------------------------------------|--------------|
| STa 6000 analyser (device) | 8059 0956 60 |
| STa 6000 battery | 8059 0955 61 |
| STa 6000 power supply ^a | 4612 0300 21 |
| Battery charger | 8059 0930 88 |
| STa 6000 battery charger adapter | 8059 0955 75 |
| STa 6000 stand | 8059 0956 73 |
| STa 6000 USB/Serial adapter | 8059 0956 74 |
| STa 6000 rubber protection | 8059 0956 76 |
| RBU QC for STa 6000 | 8059 0956 62 |
| RBU AA for STa 6000 | 8059 0956 63 |
| IRC-B Module | 8059 0920 10 |
| IRC-W Module | 8059 0920 15 |
| Bar Code Module | 8059 0920 12 |
| ACTA RS232 cable 3 m | 4222 0546 03 |
| ACTA RS232 cable 5 m | 4222 0546 05 |

^a STa 6000 is provided with the power supply in the box.

Battery has to be ordered separately.



STa 6000

STa 6000 BASIC

BASIC is the perfect solution for simple and quick tests.

STa 6000 QC

QC version for operators requiring a complete testing solution.

STa 6000 AA

AA version is the recommended solution for Advanced Analysis.

| | BASIC | QC | AA RBU |
|--|-------------------------|-------------------------|-------------------------|
| HARDWARE CAPABILITY | | | |
| Number of Channel | 1 | 1 | 1 |
| Torque | yes | yes | yes |
| Angle (Encoder or Gyroscope) | yes | yes | yes |
| MRTT-C connection for joint checks | yes | yes | yes |
| Size in mm | 110x200x45 | 110x200x45 | 110x200x45 |
| Weight [grams] | <= 500 | <= 500 | <= 500 |
| Color Display | yes | yes | yes |
| Keyboard | yes | yes | yes |
| Results Storage | 50000 | 50000 | 50000 |
| Traces storage | 50000 | 50000 | 50000 |
| RBU - Rapid Backup Unit | no | yes | yes |
| Direct Power Supply (slow charger 6H) | yes | yes | yes |
| RJ45 (Ethernet) | yes | yes | yes |
| USB | yes | yes | yes |
| Non Atlas Copco analog transducer connection | yes | yes | yes |
| SOFTWARE CAPABILITY - ONBOARD | | | |
| Languages | yes | yes | yes |
| Multi-units | yes | yes | yes |
| Pset | 1 (not saved) | 1000 | 1000 |
| Batch Count | yes | yes | yes |
| CW/CCW | yes | yes | yes |
| Database - Tool | no | 1000 | 1000 |
| Quick Programming | yes | yes | yes |
| Power Focus and Power Macs calibration | no | yes | yes |
| Traces on display | no | yes | yes |
| Advanced analysis graphs on display | no | no | yes |
| Custom measurement screen | no | yes | yes |
| Wi-Fi print | yes (with IRC-W module) | yes (with IRC-W module) | yes (with IRC-W module) |
| Ethernet print | yes | yes | yes |
| SOFTWARE FUNCTIONALTIES - ONBOARD | | | |
| Tool Check | | | |
| Wrench testing | yes | yes | yes |
| Power tool testing | yes | yes | yes |
| Pulse Tool testing | yes | yes | yes |
| Min, Max, Med, Sigma statistics | yes | yes | yes |
| Cm/Cmk | no | yes | yes |
| SPC | no | yes | yes |
| Joint Check | | | |
| Yield point | yes | yes | yes |
| Residual Torque/Time | yes | yes | yes |
| Residual Torque/Angle | yes | yes | yes |
| Residual Torque/Peak | yes | yes | yes |
| Loose and Tight | yes | yes | yes |
| SOFTWARE CAPABILITY - CONNECTIVITY | | | |
| ToolsTalk BLM to view/export results and traces via Wi-Fi (with IRC-W), USB/RJ45 | yes | yes | yes |
| ToolsTalk BLM to program test strategies via Wi-Fi (with IRC-W), USB/RJ45 | no | yes | yes |
| Torque Supervisor via Wi-Fi (with IRC-W), USB/RJ45 | no | yes | yes |
| API via Wi-Fi (with IRC-W), USB/RJ45 | no | yes (with API RBU) | yes (with API RBU) |

SRTT-L

SRTT-L is a family of transducers for the STAnalyser. It is designed for lower torque assembly tools. Both transducers and test joints are exchangeable and can be used with any STAnalyser. The modular design allows the user to scale his system as his needs evolve. The same SRTT-L plate can be used with any transducer in the SRTT-L family.



| Model | Ordering No. |
|-------------------|--------------|
| SRTT-L main plate | 8059 0955 85 |

SRTT-L TRANSDUCERS

| Model | Rated capacity | | Ordering No. |
|--------------|----------------|-------|--------------|
| | Nm | ft lb | |
| SRTT-L 1 Nm | 1 | 0.73 | 8059 0955 86 |
| SRTT-L 4 Nm | 4 | 2.95 | 8059 0955 87 |
| SRTT-L 12 Nm | 12 | 8.85 | 8059 0955 88 |
| SRTT-L 30 Nm | 30 | 22.12 | 8059 0955 89 |

TEST JOINT FOR SRTT-L

| Model | Screw size | Rated capacity | | Ordering No. |
|---------------------|------------|----------------|-------|--------------|
| | | Nm | ft lb | |
| TJ SRTT-L M4 S -1 | M4 | 1 | 0.73 | 4145 0984 80 |
| TJ SRTT-L M4 H -1 | M4 | 1 | 0.73 | 4145 0984 83 |
| TJ SRTT-L M6 S -4 | M6 | 4 | 2.95 | 4145 0984 82 |
| TJ SRTT-L M6 H -4 | M6 | 4 | 2.95 | 4145 0984 85 |
| TJ SRTT-L M6 S -12 | M6 | 12 | 8.85 | 4145 0985 80 |
| TJ SRTT-L M6 H -12 | M6 | 12 | 8.85 | 4145 0985 82 |
| TJ SRTT-L M8 S -12 | M8 | 12 | 8.85 | 4145 0985 81 |
| TJ SRTT-L M8 H -12 | M8 | 12 | 8.85 | 4145 0985 83 |
| TJ SRTT-L M8 S -30 | M8 | 30 | 22.12 | 4145 0986 80 |
| TJ SRTT-L M8 H -30 | M8 | 30 | 22.12 | 4145 0986 82 |
| TJ SRTT-L M10 S -30 | M10 | 30 | 22.12 | 4145 0986 81 |
| TJ SRTT-L M10 H -30 | M10 | 30 | 22.12 | 4145 0986 83 |

QRTT

Transducers used for QST, QMX and ETX nutrunner as well as for fixtured Tensor tool calibration. This transducer enables fast, easy set-up with highest system accuracy. By using the QRTT, no special test adaptation device between the spindle and the product itself is needed.

QRTT



| Model | Drive square in | For QMX spindle | Torque range | | Ordering No. |
|------------------|-----------------|-----------------|--------------|---------|--------------|
| | | | Nm | ft lb | |
| QRTT 20 Nm kit | 3/8 | 42 | 4-20 | 3-15 | 8092 1164 13 |
| QRTT 75 Nm kit | 3/8 | 42 | 15-75 | 11-55 | 8092 1164 18 |
| QRTT 200 Nm kit | 1/2 | 50 | 40-200 | 30-150 | 8092 1164 23 |
| QRTT 500 Nm kit | 3/4 | 62 | 100-500 | 74-369 | 8092 1164 28 |
| QRTT 1000 Nm kit | 1 | 80, 90 | 200-1000 | 148-737 | 8092 1164 33 |

IRTT-B

IRTT-B is the new generation of Atlas Copco torque and torque/angle in-line rotary transducers incorporating significant improvements in durability and accuracy. They can also work with pulse tools thanks to their revolutionary and unique solution for the slip ring and brush block. Also new is the angle reading system that uses a patent solution which gives better resolution and longer life. The mechanics have also been completely reviewed to achieve a higher level of durability.

IRTT-B is equipped by a memory chip that is read by the Atlas Copco data analyser. In this way the Data analyser is automatically calibrated to the transducer sensitivity and avoid any possible set up errors.



IRTT-B

| Model | Drive | | Torque range | | Ordering No. | Model | Drive | | Torque range | | Ordering No. |
|----------------------|--------|-----------|--------------|------------|--------------|----------------------------|--------|-----------|--------------|------------|--------------|
| | Hex in | Square in | Nm | ft lb | | | Hex in | Square in | Nm | ft lb | |
| Torque models | | | | | | Torque/angle models | | | | | |
| IRTT-B 5-I06 | 1/4 | | 1-5 | 0.8-3.6 | 8059 0942 05 | IRTT-B 1A-I06 | 1/4 | | 0.2-1 | 0.14-0.73 | 8059 0943 96 |
| IRTT-B 5-06 | | 1/4 | 1-5 | 0.8-3.6 | 8059 0942 07 | IRTT-B-2A-I06 | 1/4 | | 0.4-2 | 0.3-1.47 | 8059 0943 01 |
| IRTT-B 20-I06 | 1/4 | | 4-20 | 3-15 | 8059 0942 10 | IRTT-B 5A-I06 | 1/4 | | 1-5 | 0.8-3.6 | 8059 0943 06 |
| IRTT-B 20-06 | | 1/4 | 4-20 | 3-15 | 8059 0942 15 | IRTT-B 5A-06 | | 1/4 | 1-5 | 0.8-3.6 | 8059 0943 08 |
| IRTT-B 25 -10 | | 3/8 | 5-25 | 3.7-18.4 | 8059 0942 20 | IRTT-B 20A-I06 | 1/4 | | 4-20 | 3-15 | 8059 0943 11 |
| IRTT-B 75-10 | | 3/8 | 15-75 | 11-55 | 8059 0942 25 | IRTT-B 20A-06 | | 1/4 | 4-20 | 3-15 | 8059 0943 16 |
| IRTT-B 180-13 | | 1/2 | 36-180 | 27-133 | 8059 0942 30 | IRTT-B 25A-10 | | 3/8 | 5-25 | 3.7-18.4 | 8059 0943 21 |
| IRTT-B 500-20 | | 3/4 | 100-500 | 74-369 | 8059 0942 35 | IRTT-B 75A-10 | | 3/8 | 15-75 | 11-55 | 8059 0943 26 |
| IRTT-B 750-25 | | 1 | 150-750 | 111-553 | 8059 0942 40 | IRTT-B 180A-13 | | 1/2 | 36-180 | 27-133 | 8059 0943 31 |
| IRTT-B 1400-25 | | 1 | 280-1400 | 206.6-1033 | 8059 0942 45 | IRTT-B 500A-20 | | 3/4 | 100-500 | 74-369 | 8059 0943 36 |
| IRTT-B 3000-38 | | 1 1/2 | 600-3000 | 440-2200 | 8059 0942 52 | IRTT-B 750A-25 | | 1 | 150-750 | 111-553 | 8059 0943 41 |
| IRTT-B 5000-38 | | 1 1/2 | 1000-5000 | 737-3685 | 8059 0942 56 | IRTT-B 1400A-25 | | 1 | 280-1400 | 206.6-1033 | 8059 0943 46 |
| | | | | | | IRTT-B 3000A-38 | | 1 1/2 | 600-3000 | 440-2200 | 8059 0943 52 |
| | | | | | | IRTT-B 5000A-38 | | 1 1/2 | 1000-5000 | 737-3685 | 8059 0943 56 |
| | | | | | | IRTT-B 10000A-38 | | 1 1/2 | 2000-10000 | 1474-7370 | 8059 0943 60 |

NOTE: All IRTT are equipped with 19-pin connector.

SRTT-B

STATIONARY REACTION TORQUE TRANSDUCER

Stationary reaction torque transducers are designed for testing wrenches, click wrenches or for tightening tools where rotary action is not desired during measurement. When testing a shut-off tool, a joint simulator is required as an accessory.

The SRTT-B is the new generation of Atlas Copco stationary reaction torque transducers with improved durability thanks to their new mechanical design. The new patented system of fixing the joint simulator on top avoids any possible errors due to the play between the two devices.

A complete range of accessories and a mechanical joint simulator enables you to test shut-off tools or wrenches with square drive output.



SRTT-B

| Model | Drive | | Torque range | | Ordering No. |
|----------------|--------|-----------|--------------|-----------|--------------|
| | Hex mm | Square in | Nm | ft lb | |
| SRTT-B 0.5-13 | | 1/2 | 0.1-0.5 | 0.08-0.37 | 8059 0946 03 |
| SRTT-B 2-13 | | 1/2 | 0.4-2 | 0.3-1.47 | 8059 0946 09 |
| SRTT-B 5-13 | | 1/2 | 1-5 | 0.8-3.6 | 8059 0946 15 |
| SRTT-B 10-13 | | 1/2 | 2-10 | 1.5-7.3 | 8059 0946 21 |
| SRTT-B 25-36 | 36 | | 5-25 | 3.7-18.4 | 8059 0946 28 |
| SRTT-B 50-36 | 36 | | 10-50 | 7.4-36 | 8059 0946 36 |
| SRTT-B 100-36 | 36 | | 20-100 | 14.8-73 | 8059 0946 45 |
| SRTT-B 250-36 | 36 | | 50-250 | 37-184 | 8059 0946 54 |
| SRTT-B 500-50 | 50 | | 100-500 | 74-368 | 8059 0946 63 |
| SRTT-B 1000-50 | 50 | | 200-1000 | 148-737 | 8059 0946 75 |
| SRTT-B 2000-50 | 50 | | 400-2000 | 295-1475 | 8059 0946 84 |

TEST JOINT FOR SRTT-B



Test joint for SRTT-B

| Model | SRTT-B Drive | | Tool drive | | Rated capacity | | Ordering No. |
|-------------------|--------------|-----------|------------|-----------|----------------|--------|--------------|
| | Hex mm | Square in | Hex mm | Square in | Nm | ft lb | |
| TJ SRTT-B S -0.5 | | 1/2 | 1/4 | | 0.5 | 0.37 | 8059 0940 01 |
| TJ SRTT-B H -0.5 | | 1/2 | 1/4 | | 0.5 | 0.37 | 8059 0940 02 |
| TJ SRTT-B S -2 | | 1/2 | 1/4 | | 2 | 1.47 | 8059 0940 03 |
| TJ SRTT-B H -2 | | 1/2 | 1/4 | | 2 | 1.47 | 8059 0940 04 |
| TJ SRTT-B S -5 | | 1/2 | 1/4 | | 5 | 3.69 | 8059 0940 05 |
| TJ SRTT-B S -5 | | 1/2 | 1/4 | | 5 | 3.69 | 8059 0940 06 |
| TJ SRTT-B S -10 | | 1/2 | 1/4 | | 10 | 7.36 | 8059 0940 20 |
| TJ SRTT-B H -10 | | 1/2 | 1/4 | | 10 | 7.36 | 8059 0940 21 |
| TJ SRTT-B S -25 | 36 | | | 3/8 | 25 | 18.40 | 8059 0940 07 |
| TJ SRTT-B H -25 | 36 | | | 3/8 | 25 | 18.40 | 8059 0940 08 |
| TJ SRTT-B S -50 | 36 | | | 1/2 | 50 | 36.88 | 8059 0940 09 |
| TJ SRTT-B H -50 | 36 | | | 1/2 | 50 | 36.88 | 8059 0940 10 |
| TJ SRTT-B S -100 | 36 | | | 1/2 | 100 | 73.76 | 8059 0940 11 |
| TJ SRTT-B H -100 | 36 | | | 1/2 | 100 | 73.76 | 8059 0940 12 |
| TJ SRTT-B S -250 | 36 | | | 1/2 | 250 | 184.40 | 8059 0940 13 |
| TJ SRTT-B H -250 | 36 | | | 1/2 | 250 | 184.40 | 8059 0940 14 |
| TJ SRTT-B S -500 | 50 | | | 3/4 | 500 | 368.78 | 8059 0940 15 |
| TJ SRTT-B H -500 | 50 | | | 3/4 | 500 | 368.78 | 8059 0940 16 |
| TJ SRTT-B 1000-50 | 50 | | | 1 | 1000 | 737.60 | 8059 0940 17 |

Optional Accessories

Adapter



Square socket



ADAPTERS

| Adapter | Drive | | Ordering No. |
|--------------|--------|-----------|--------------|
| | Hex mm | Square in | |
| 1/2" to 1/4" | | 1/2 | 8059 0978 63 |
| 1/2" to 3/8" | | 1/2 | 8059 0978 64 |
| 3/8" to 36 | 36 | | 8059 0978 65 |
| 1/2" to 36 | 36 | | 8059 0978 66 |
| 1/2" to 50 | 50 | | 8059 0978 67 |
| 3/4" to 50 | 50 | | 8059 0978 68 |
| 1" to 50 | 50 | | 8059 0978 69 |

SQUARE SOCKETS

| Adapter | Ordering No. |
|-------------|--------------|
| 1/4" - 1/4" | 8059 0977 64 |
| 3/8" - 3/8" | 8059 0977 65 |
| 1/2" - 1/2" | 8059 0977 66 |
| 3/4" - 3/4" | 8059 0977 67 |
| 1" - 1" | 8059 0978 52 |
| 1/4" - 3/8" | 8059 0977 68 |
| 3/8" - 1/2" | 8059 0977 69 |
| 1/2" - 3/4" | 8059 0977 70 |
| 3/4" - 1" | 8059 0978 53 |

MRTT-B SCREWDRIVER

MRTT-B is available in a screwdriver version for low torque applications from 0.1 to 15 Nm. The 15 Nm model has a precision reversible 1/4" drive ratchet consisting of two needle clutches. Sliding bush to convert left and right tightening. The very low friction avoids dragging the screws on the return motion.



MRTT-B

| Model | Torque capacity | | Square drive in | Weight | | Length mm | Ordering No. |
|--------------|-----------------|-----------|-----------------|--------|------|-----------|--------------|
| | Nm | ft lb | | kg | lb | | |
| MRTT-B 1-06 | 0.1-1 | 0.07-0.74 | 1/4 | 0.3 | 0.66 | 169 | 8059 0931 06 |
| MRTT-B 5-06 | 0.5-5 | 0.36-3.67 | 1/4 | 0.3 | 0.66 | 169 | 8059 0931 15 |
| MRTT-B 15-06 | 1.5-15 | 1.1-11.1 | 1/4 | 0.4 | 0.88 | 223 | 8059 0931 24 |

Optional Accessories

TRANSDUCER CABLE

The cable needed for all transducers and MRTT-B.

CABLES

| Length | Ordering No. |
|------------------|--------------|
| 1 m | 4145 0982 01 |
| 3 m | 4145 0982 03 |
| 5 m | 4145 0982 05 |
| 3 m curled cable | 4145 0971 03 |

If non Atlas Copco transducers are used one of the following cables are required.

| Model | Ordering No. |
|---|--------------|
| Industrial style Transducer cable 3 m 19 - 4 | 4145 0965 03 |
| Industrial style Transducer cable 3 m 19 - 6 | 4145 0968 03 |
| Industrial style Transducer cable 3 m 19 - 10 | 4145 0967 03 |

MRTT-C

The MRTT-C is a revolutionary way to think about a manual wrench. The MRTT-C is an advanced handle that can be connected to the standard smartHEAD used for the STwrench to create a wrench that can be connected to the STAnalyser using a standard Atlas Copco cable.

The MRTT-C connected to the STAnalyser with Residual or Production RBU can be used to detect the residual torque using the advanced Torque/Angle algorithm, same as the STwrench, or to tight a bolt for production applications.

- Torque or Torque/Angle reading depending to the smartHEAD
- Led ring like STwrench
- Vibrating handle
- Buzzer
- TAG recognition
- Light in front



MRTT-C

| Model | Ordering No. |
|--------|--------------|
| MRTT-C | 8059 0930 10 |

| Model | Capacity | | Drive mm | Weight | | Length mm | Ordering No. |
|--------------------------------------|----------|---------|-------------|--------|------|--------------|--------------|
| | Nm | ft lb | | kg | lb | | |
| smartHEAD only Torque | | | | | | | |
| smartHEAD 30 | 6-30 | 4.5-22 | 9x12 | 0.20 | 0.44 | 167.5 | 8059 0920 31 |
| smartHEAD 80 | 16-80 | 12-59 | 9x12 | 0.22 | 0.48 | 167.5 | 8059 0920 43 |
| smartHEAD 150 | 30-150 | 23-111 | 14x18 | 0.55 | 1.21 | 271.0 | 8059 0920 48 |
| smartHEAD 250 | 50-250 | 37-184 | 14x18 | 0.78 | 1.72 | 417.0 | 8059 0920 54 |
| smartHEAD 400 | 80-400 | 59-295 | 14x18 | 0.93 | 2.05 | 584.0 | 8059 0920 60 |
| smartHEAD 600 | 120-600 | 89-443 | 21x26 | 1.70 | 3.75 | 1048.5 | 8059 0920 66 |
| smartHEAD 1000 | 300-1000 | 148-737 | 28 | 1.90 | 4.19 | 1344 | 8059 0920 80 |
| smartHEAD A Torque + Angle | | | | | | | |
| smartHEAD A15 | 3-15 | 2.2-11 | 9x12 | 0.19 | 0.42 | 147.5 | 8059 0930 24 |
| smartHEAD A30 | 6-30 | 4.5-22 | 9x12 | 0.19 | 0.42 | 147.5 | 8059 0930 31 |
| smartHEAD A80 | 16-80 | 12-59 | 9x12 | 0.20 | 0.44 | 147.5 | 8059 0930 43 |
| smartHEAD A150 | 30-150 | 23-111 | 14x18 | 0.57 | 1.25 | 271.0 | 8059 0930 48 |
| smartHEAD A250 | 50-250 | 37-184 | 14x18 | 0.80 | 1.76 | 417.0 | 8059 0930 54 |
| smartHEAD A400 | 80-400 | 59-295 | 14x18 | 0.95 | 2.09 | 584.0 | 8059 0930 60 |
| smartHEAD A600 | 120-600 | 89-443 | 21x26 | 1.72 | 3.79 | 1048.5 | 8059 0930 66 |
| smartHEAD A800 | 160-800 | 118-590 | 21x26 | 1.70 | 3.75 | 1048.5 | 8059 0988 26 |
| smartHEAD A1000 | 300-1000 | 148-737 | 28 | 1.90 | 4.19 | 1344 | 8059 0930 80 |
| smartHEAD A Torque + Angle sq | | | | | | | |
| smartHEAD Asq15 | 3-15 | 2.2-11 | 9x12 | 0.19 | 0.42 | 147.5 | 8059 0930 28 |
| smartHEAD Asq30 | 6-30 | 4.5-22 | 9x12 | 0.19 | 0.42 | 147.5 | 8059 0930 32 |
| smartHEAD Asq80 | 16-80 | 12-59 | 9x12 | 0.20 | 0.44 | 147.5 | 8059 0930 44 |
| smartHEAD Asq150 | 30-150 | 23-111 | 14x18 | 0.55 | 1.21 | 271.0 | 8059 0930 50 |
| smartHEAD Asq250 | 50-250 | 37-184 | 14x18 | 0.78 | 1.72 | 417.0 | 8059 0930 56 |
| smartHEAD Asq400 | 80-400 | 59-295 | 14x18 | 0.93 | 2.05 | 584.0 | 8059 0930 62 |

Dimensions

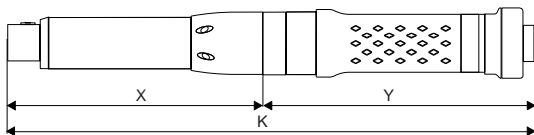

| Model | X mm | Length | | Total weight | |
|----------------|---------|---------|---------|--------------|------|
| | | Y mm | K mm | kg | lb |
| MRTT-C 15 Nm | 139 | 166 | 325 | 0.60 | 1.29 |
| MRTT-C 30 Nm | 139 | 166 | 325 | 0.62 | 1.36 |
| MRTT-C 80 Nm | 139 | 166 | 325 | 0.64 | 1.41 |
| MRTT-C 150 Nm | 262 | 166 | 428 | 0.97 | 2.13 |
| MRTT-C 250 Nm | 408 | 166 | 574 | 1.20 | 2.64 |
| MRTT-C 400 Nm | 575 | 166 | 741 | 1.35 | 2.97 |
| MRTT-C 600 Nm | 1040 | 166 | 1206 | 2.12 | 4.67 |
| MRTT-C 800 Nm | 1040 | 166 | 1206 | 2.12 | 4.67 |
| MRTT-C 1000 Nm | 1270 | 166 | 1436 | 2.97 | 6.54 |

Optional Accessories

TRANSDUCER CABLE

The cable needed for all transducers and MRTT-C.

If non Atlas Copco transducers are used one of the following cables are required.

CABLES

| Length | Ordering No. |
|------------------|--------------|
| 1 m | 4145 0982 01 |
| 3 m | 4145 0982 03 |
| 5 m | 4145 0982 05 |
| 3 m curled cable | 4145 0971 03 |

| Model | Ordering No. |
|---|--------------|
| Industrial style Transducer cable 3 m 19 - 4 | 4145 0965 03 |
| Industrial style Transducer cable 3 m 19 - 6 | 4145 0968 03 |
| Industrial style Transducer cable 3 m 19 - 10 | 4145 0967 03 |

QUALITY ASSURANCE SYSTEM – SHARPENING YOUR COMPETITIVE EDGE

To ensure the highest quality of your fastening – and ultimately your company’s products – Atlas Copco has developed a comprehensive quality assurance system for micro torques. The ACTA MT4 system provides fast, accurate and reliable measurement of critical parameters.

ACTA MT4 – SMART FEATURES

- Connect to PC via USB/RS232/Ethernet.
- 6 different engineering units to choose from.
- Colour configurable display (Torque/Angle/Status/Trace).
- Battery for portable usage.
- Programmable via keypad or software “ToolsTalk ACTA MT”.
- Dual transducer inputs.
- High resolution OLED colour display.
- Audio signal for operator feedback.
- Digital I/O signals for communication with external devices such as PLC.
- Tool speed measurement function possible when using MT TRA transducers.
- Store and export tightening data to excel with ToolsTalk ACTA MT PC software.
- Calculate average torque directly on the display.



MT TRA 500



MT TH



ACTA MT 4



MT TS

| Model | Capacity | | Drive | Overall length mm | Ordering No. |
|---|----------|-------|--------|----------------------|--------------|
| | cNm | in lb | | | |
| Torque Analyzer | | | | | |
| ACTA MT 4 ^a | | | | | 8432 0820 04 |
| Manual screwdriver torque transducer | | | | | |
| MT TH 1 | 1.0 | 0.09 | Ø 3 mm | 115 | 8432 0820 10 |
| MT TH 2 | 2.0 | 0.18 | Ø 3 mm | 115 | 8432 0820 11 |
| MT TH 5 | 5.0 | 0.44 | Ø 3 mm | 115 | 8432 0820 12 |
| MT TH 10 | 10.0 | 0.88 | Ø 3 mm | 115 | 8432 0820 13 |
| MT TH 20 | 20.0 | 1.77 | Ø 3 mm | 115 | 8432 0820 14 |
| MT TH 50 | 50.0 | 4.42 | 1/4" | 124 | 8432 0820 15 |
| MT TH 100 | 100.0 | 8.85 | 1/4" | 124 | 8432 0820 16 |
| MT TH 200 | 200.0 | 17.70 | 1/4" | 124 | 8432 0820 17 |
| Stationary reaction torque transducer | | | | | |
| MT TS 5 | 5.0 | 0.44 | Ø 3 mm | 81 | 8432 0820 20 |
| MT TS 10 | 10.0 | 0.88 | Ø 3 mm | 81 | 8432 0820 21 |
| MT TS 20 | 20.0 | 1.77 | Ø 3 mm | 81 | 8432 0820 22 |
| MT TS 50 | 50.0 | 4.42 | 1/4" | 98 | 8432 0820 23 |
| MT TS 100 | 100.0 | 8.85 | 1/4" | 98 | 8432 0820 24 |
| MT TS 200 | 200.0 | 17.70 | 1/4" | 98 | 8432 0820 25 |
| MT TS 500 | 500.0 | 44.25 | 1/4" | 111 | 8432 0820 52 |
| In-line rotary torque and angle transducer | | | | | |
| MT TRA 5 | 5.0 | 0.44 | Ø 3 mm | 76 | 8432 0820 42 |
| MT TRA 10 | 10.0 | 0.88 | Ø 5 mm | 76 | 8432 0820 43 |
| MT TRA 20 | 20.0 | 1.77 | Ø 5 mm | 76 | 8432 0820 44 |
| MT TRA 50 | 50.0 | 4.42 | 1/4" | 105 | 8432 0820 45 |
| MT TRA 100 | 100.0 | 8.85 | 1/4" | 105 | 8432 0820 46 |
| MT TRA 200 | 200.0 | 17.70 | 1/4" | 105 | 8432 0820 47 |
| MT TRA 500 | 500.0 | 44.25 | 1/4" | 105 | 8432 0820 48 |

^a ToolsTalk ACTA MT (programming software) included.

CABLES

| Model | Ordering No. |
|---------------------|--------------|
| Transducer cable | 8432 0830 35 |
| RS232 cable ACTA MT | 8432 0831 39 |

TEST JOINTS FOR CALIBRATION WITH MT TS

| Model | Designation | Range cNm | Drive | Screw head profile | Ordering No. |
|------------|---------------|--------------|----------|-----------------------|--------------|
| Test joint | M6 Soft joint | 500 - 1000 | 1/4" HEX | HEX 5 mm | 8432 0833 62 |
| | M6 Soft joint | 200 - 500 | 1/4" HEX | HEX 5 mm | 8432 0833 61 |
| | M4 Soft joint | 27 - 200 | 1/4" HEX | HEX 3 mm | 8432 0833 60 |
| | M3 Soft joint | 5 - 27 | 1/4" HEX | HEX 3 mm | 8432 0833 59 |
| | M3 Soft joint | 5 - 27 | Ø 3 mm | HEX 3 mm | 8432 0833 58 |
| | M2 Soft joint | 0 - 10 | 1/4" HEX | HEX 1.5 mm | 8432 0833 57 |
| | M2 Soft joint | 0 - 10 | Ø 3 mm | HEX 1.5 mm | 8432 0833 56 |
| | M6 Hard joint | 200 - 1000 | 1/4" HEX | HEX 5 mm | 8432 0833 55 |
| | M4 Hard joint | 27 - 200 | 1/4" HEX | HEX 3 mm | 8432 0833 54 |
| | M3 Hard joint | 5 - 27 | 1/4" HEX | HEX 3 mm | 8432 0833 53 |
| | M3 Hard joint | 5 - 27 | Ø 3 mm | HEX 3 mm | 8432 0833 52 |
| | M2 Hard joint | 0 - 10 | 1/4" HEX | HEX 1.5 mm | 8432 0833 51 |
| | M2 Hard joint | 0 - 10 | Ø 3 mm | HEX 1.5 mm | 8432 0833 50 |

Mechanical wrench series

The mechanical wrenches in the new Atlas Copco Saltus product line form the basis for manual tightening. They enable you to find the optimal solution for your individual tightening situation regardless whether you are working in assembly lines, rework or repair and maintenance, and even when limited operating space is available.

The wrenches are also the perfect back-up strategy for your controlled assembly technology.

With regard to workplace equipment and costs, manual tightening wrenches are often more efficient and increase your productivity. The easy handling has earned wide acceptance among operators.

Our different wrench types offer the right strategy for nearly any application.

Optional setting keys are available for adjustments of the pre-set value for all wrenches.

CWR 'CLICK' WRENCH SERIES

The torque wrenches in our CWR series provide the distinctive "Click" which is a very clear feedback when reaching the pre-set torque value. The repeatability of $\pm 4\%$ makes them perfect for use in assembly lines.

BWR 'BREAKING' WRENCH SERIES

The torque wrenches in our BWR series are primarily used in professional industrial environments. The possibility of over-tightening is significantly reduced due to a 22° breaking-angle of the unique BWR mechanism. Therefore, the BWR wrenches are very well-suited for use in assembly lines as well as for repair and maintenance.

You can profit from a wide range of end fittings which are quickly changed. Coupled with our Atlas Copco end fittings for the BWR series, you will obtain a high degree of accuracy in your tightening process.

SWR 'SLIPPING' WRENCH SERIES

The torque wrenches in the SWR series are "automatically triggered" once the pre-set torque value is reached. The Camover-technology completely avoids over-tightening. After triggering, the SWR wrench is again ready to use. The integrated ratchet



function ensures you controlled clockwise tightening. The high repeating accuracy with a tolerance of $\pm 4\%$ makes the SWR wrenches ideal for assembly lines for extreme continuous operation.

Mechanical Wrenches

CWR 'CLICK' WRENCH SERIES

- Wide range from 2Nm up to 300Nm.
- Reversible version "R" for tightening in both directions.
- Very small sizes ideal for tightening in limited space.
- Repeatability of $\pm 4\%$.
- Easy and safe adjusting and handling.
- Standard drive (9x12 or 14x18) for a wide range of suitable end fittings.



| Model | Torque range | | Length mm | Weight g | Ø mm | Drive | Ordering No. |
|-------------------------------|--------------|----------|--------------|-------------|---------|-------|--------------|
| | Nm | ft lb | | | | | |
| CWR-20 | 3-20 | 2.2-14.8 | 129 | 248 | 21 | 9x12 | 8439 0041 00 |
| CWR-25 | 2-25 | 1.5-18.4 | 174 | 288 | 21 | 9x12 | 8439 0041 01 |
| CWR-50 | 5-50 | 3.7-37 | 236 | 466 | 21 | 9x12 | 8439 0041 02 |
| CWR-85 | 15-85 | 11-62.7 | 305 | 576 | 21 | 9x12 | 8439 0041 03 |
| CWR-120 | 50-120 | 37-88.5 | 349 | 666 | 24 | 9x12 | 8439 0041 04 |
| CWR-200 | 50-200 | 37-148 | 419 | 916 | 30x26 | 14x18 | 8439 0041 05 |
| CWR-300 | 60-300 | 44.2-221 | 685 | 1366 | 32x28 | 14x18 | 8439 0041 06 |
| Reversible wrench type | | | | | | | |
| CWR-20 R | 3-20 | 2.2-14.8 | 129 | 248 | 21 | 9x12 | 8439 0041 10 |
| CWR-25 R | 2-25 | 1.5-18.4 | 174 | 288 | 21 | 9x12 | 8439 0041 11 |
| CWR-50 R | 5-50 | 3.7-37 | 236 | 466 | 21 | 9x12 | 8439 0041 12 |
| CWR-85 R | 15-85 | 11-62.7 | 305 | 576 | 21 | 9x12 | 8439 0041 13 |
| CWR-120 R | 50-120 | 37-88.5 | 349 | 666 | 24 | 9x12 | 8439 0041 14 |

BWR - 'BREAKING' WRENCH SERIES

- High process reliability as over-tightening is significantly reduced due to the 22° breaking angle.
- Wide range of wrenches from 2Nm up to 2000Nm.
- Extremely high durability and high repeatability of $\pm 4\%$.
- Robust construction.
- Easy and safe adjusting.



| Model | Torque range | | Length mm | Weight g | Ø mm | Drive | Ordering No. |
|----------|--------------|-----------|--------------|-------------|---------|-----------|--------------|
| | Nm | ft lb | | | | | |
| BWR-20 | 2-20 | 1.5-14.8 | 213 | 250 | 8x16 | BWR-20/35 | 8439 0042 00 |
| BWR-35 | 5-35 | 3.7-25.8 | 288 | 550 | 8x16 | BWR-20/35 | 8439 0042 01 |
| BWR-100 | 20-100 | 14.8-74 | 410 | 950 | 10x20 | BWR-100 | 8439 0042 02 |
| BWR-240 | 80-240 | 59-177 | 677 | 2700 | 14x30 | BWR-240 | 8439 0042 03 |
| BWR-440 | 140-440 | 103-324.5 | 857 | 4300 | 16x34 | BWR-440 | 8439 0042 04 |
| BWR-750 | 300-750 | 221-553 | 961 | 6400 | 20x41 | BWR-750 | 8439 0042 05 |
| BWR-1300 | 500-1300 | 369-959 | 1256 | 8140 | 21x45 | BWR-1300 | 8439 0042 06 |
| BWR-2000 | 800-2000 | 590-1475 | 1982 | 13450 | 21x45 | BWR-2000 | 8439 0042 07 |

SWR 'SLIPPING' WRENCH SERIES

- Torque range from 5 Nm up to 110Nm.
- High process reliability as camover mechanism avoids over-tightening.
- Overloading of the wrench itself is impossible.
- Repeatability of $\pm 4\%$.
- Robust construction.
- Easy and safe adjusting.
- 3/8" (SWR-30 / SWR-60) respectively 1/2" (SWR-110) ratchet drive allows use of standard sockets.



| Model | Torque range | | Length mm | Weight g | Drive | Ordering No. |
|---------|--------------|---------|--------------|-------------|-------|--------------|
| | Nm | ft lb | | | | |
| SWR-30 | 5-30 | 3.7-22 | 269 | 640 | 3/8" | 8439 0043 00 |
| SWR-60 | 15-60 | 11-44 | 354 | 1050 | 3/8" | 8439 0043 01 |
| SWR-110 | 40-110 | 29.5-96 | 453 | 1900 | 1/2" | 8439 0043 02 |

Open End

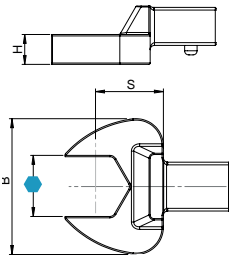

| mm/in | B mm | H mm | S mm | g | Max Nm | Ordering No. |
|----------------|------|------|------|-----|--------|--------------|
| 9 x 12 | | | | | | |
| 7 | 22 | 5 | 17.5 | 40 | 7 | 4027 5011 00 |
| 8 | 22 | 5 | 17.5 | 39 | 10 | 4027 5011 01 |
| 9 | 26 | 5.5 | 17.5 | 38 | 14 | 4027 5011 02 |
| 10 | 26 | 5.5 | 17.5 | 42 | 20 | 4027 5011 03 |
| 11 | 26 | 5.5 | 17.5 | 41 | 25 | 4027 5011 04 |
| 12 | 30 | 7 | 17.5 | 43 | 32 | 4027 5011 05 |
| 13 | 30 | 7 | 17.5 | 48 | 40 | 4027 5011 06 |
| 14 | 35 | 8 | 17.5 | 52 | 50 | 4027 5011 07 |
| 15 | 35 | 8 | 17.5 | 51 | 60 | 4027 5011 08 |
| 16 | 38 | 8.5 | 17.5 | 58 | 70 | 4027 5011 09 |
| 17 | 38 | 8.5 | 17.5 | 60 | 80 | 4027 5011 10 |
| 18 | 42 | 9 | 20 | 71 | 100 | 4027 5011 11 |
| 19 | 42 | 9 | 20 | 74 | 115 | 4027 5011 12 |
| 20 | 42 | 9 | 20 | 76 | 115 | 4027 5011 13 |
| 21 | 46 | 11 | 22 | 95 | 115 | 4027 5011 14 |
| 22 | 46 | 11 | 22 | 95 | 115 | 4027 5011 15 |
| 24 | 48 | 11 | 25 | 106 | 130 | 4027 5011 16 |
| 27 | 58 | 13 | 30 | 235 | 150 | 4027 5011 17 |
| 32 | 64 | 15 | 40 | 267 | 190 | 4027 5011 18 |
| 1/4 | 22 | 5 | 17.5 | 37 | 7 | 4027 5010 00 |
| 5/16 | 22 | 5 | 17.5 | 36 | 10 | 4027 5010 01 |
| 3/8 | 26 | 5.5 | 17.5 | 38 | 20 | 4027 5010 02 |
| 7/16 | 26 | 5.5 | 17.5 | 38 | 25 | 4027 5010 03 |
| 1/2 | 30 | 7 | 17.5 | 47 | 32 | 4027 5010 04 |
| 9/16 | 34 | 8 | 17.5 | 50 | 50 | 4027 5010 05 |
| 5/8 | 38 | 8.5 | 17.5 | 56 | 70 | 4027 5010 06 |
| 11/16 | 38 | 8.5 | 17.5 | 57 | 80 | 4027 5010 07 |
| 3/4 | 42 | 9 | 20 | 71 | 115 | 4027 5010 08 |
| 14 x 18 | | | | | | |
| 13 | 30 | 7 | 25 | 128 | 40 | 4027 5011 21 |
| 14 | 35 | 8 | 25 | 129 | 50 | 4027 5011 22 |
| 15 | 35 | 8 | 25 | 132 | 60 | 4027 5011 23 |
| 16 | 38 | 9 | 25 | 140 | 70 | 4027 5011 24 |
| 17 | 38 | 9 | 25 | 136 | 80 | 4027 5011 25 |
| 18 | 42 | 10 | 25 | 147 | 90 | 4027 5011 26 |
| 19 | 42 | 10 | 25 | 145 | 95 | 4027 5011 27 |
| 20 | 42 | 10 | 25 | 155 | 100 | 4027 5011 28 |
| 21 | 50 | 11 | 25 | 171 | 30 | 4027 5011 29 |
| 22 | 50 | 11 | 25 | 165 | 150 | 4027 5011 30 |
| 24 | 53 | 12 | 25 | 167 | 180 | 4027 5011 31 |
| 27 | 60 | 13 | 30 | 219 | 220 | 4027 5011 32 |
| 28 | 60 | 13 | 30 | 222 | 250 | 4027 5011 33 |
| 29 | 60 | 13 | 30 | 222 | 270 | 4027 5011 34 |
| 30 | 66 | 14 | 30 | 245 | 300 | 4027 5011 35 |
| 32 | 66 | 14 | 32.5 | 246 | 300 | 4027 5011 36 |
| 34 | 66 | 14 | 32.5 | 239 | 300 | 4027 5011 37 |
| 36 | 66 | 14 | 32.5 | 275 | 300 | 4027 5011 38 |
| 7/16 | 30 | 7 | 25 | 127 | 40 | 4027 5010 50 |
| 1/2 | 30 | 7 | 25 | 127 | 40 | 4027 5010 51 |
| 9/16 | 35 | 8 | 25 | 132 | 50 | 4027 5010 52 |
| 5/8 | 38 | 9 | 25 | 141 | 70 | 4027 5010 53 |
| 11/16 | 38 | 9 | 25 | 136 | 80 | 4027 5010 54 |
| 3/4 | 42 | 10 | 25 | 144 | 95 | 4027 5010 55 |
| 13/16 | 50 | 11 | 25 | 160 | 150 | 4027 5010 56 |
| 7/8 | 50 | 11 | 25 | 158 | 150 | 4027 5010 57 |
| 15/16 | 53 | 12 | 25 | 176 | 180 | 4027 5010 58 |
| 1 | 53 | 12 | 25 | 172 | 180 | 4027 5010 59 |
| 1.1/8 | 60 | 13 | 30 | 223 | 220 | 4027 5010 60 |

Box End

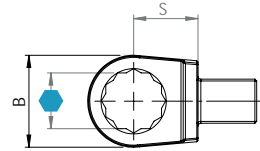

| mm/in | B mm | H mm | S mm | g | Max Nm | Ordering No. |
|----------------|------|------|------|-----|--------|--------------|
| 9 x 12 | | | | | | |
| 7 | 13 | 8 | 17.5 | 38 | 25 | 4027 5011 50 |
| 8 | 13.5 | 8 | 17.5 | 37 | 35 | 4027 5011 51 |
| 9 | 16 | 8 | 17.5 | 35 | 40 | 4027 5011 52 |
| 10 | 18 | 9 | 17.5 | 40 | 55 | 4027 5011 53 |
| 11 | 18.5 | 9 | 17.5 | 44 | 70 | 4027 5011 54 |
| 12 | 20.5 | 11 | 17.5 | 41 | 85 | 4027 5011 55 |
| 13 | 21.5 | 11 | 17.5 | 49 | 100 | 4027 5011 56 |
| 14 | 25 | 12 | 17.5 | 55 | 115 | 4027 5011 57 |
| 15 | 25 | 12 | 17.5 | 52 | 120 | 4027 5011 58 |
| 16 | 26 | 12 | 17.5 | 54 | 120 | 4027 5011 59 |
| 17 | 27 | 13 | 17.5 | 59 | 120 | 4027 5011 60 |
| 18 | 28 | 13 | 17.5 | 56 | 120 | 4027 5011 61 |
| 19 | 30.5 | 13 | 17.5 | 65 | 120 | 4027 5011 62 |
| 21 | 33 | 15 | 17.5 | 71 | 120 | 4027 5011 63 |
| 22 | 34.5 | 15 | 17.5 | 74 | 120 | 4027 5011 64 |
| 1/4 | 13.5 | 8 | 17.5 | 39 | 25 | 4027 5010 13 |
| 5/16 | 13.5 | 8 | 17.5 | 38 | 35 | 4027 5010 14 |
| 3/8 | 18 | 8 | 17.5 | 41 | 55 | 4027 5010 15 |
| 7/16 | 18 | 9 | 17.5 | 41 | 70 | 4027 5010 16 |
| 1/2 | 22 | 12 | 17.5 | 51 | 100 | 4027 5010 17 |
| 9/16 | 25 | 12 | 17.5 | 57 | 115 | 4027 5010 18 |
| 5/8 | 27 | 13 | 17.5 | 61 | 120 | 4027 5010 19 |
| 11/16 | 27 | 13 | 17.5 | 57 | 120 | 4027 5010 20 |
| 3/4 | 30 | 13 | 17.5 | 62 | 120 | 4027 5010 21 |
| 13/16 | 34 | 14.5 | 17.5 | 75 | 120 | 4027 5010 22 |
| 7/8 | 34 | 15 | 20 | 77 | 120 | 4027 5010 23 |
| 14 x 18 | | | | | | |
| 13 | 22.5 | 11 | 25 | 130 | 100 | 4027 5011 67 |
| 14 | 23 | 11 | 25 | 123 | 110 | 4027 5011 68 |
| 15 | 24 | 11 | 25 | 128 | 120 | 4027 5011 69 |
| 16 | 25.5 | 12 | 25 | 133 | 140 | 4027 5011 70 |
| 17 | 27 | 12 | 25 | 135 | 160 | 4027 5011 71 |
| 18 | 29 | 13 | 25 | 134 | 185 | 4027 5011 72 |
| 19 | 30.5 | 13 | 25 | 138 | 210 | 4027 5011 73 |
| 20 | 33 | 13 | 25 | 140 | 230 | 4027 5011 74 |
| 21 | 33 | 15 | 25 | 144 | 260 | 4027 5011 75 |
| 22 | 34.5 | 15 | 25 | 145 | 300 | 4027 5011 76 |
| 24 | 37.5 | 15 | 25 | 153 | 350 | 4027 5011 77 |
| 27 | 42.5 | 17 | 25 | 162 | 450 | 4027 5011 78 |
| 30 | 46 | 19 | 25 | 182 | 550 | 4027 5011 79 |
| 32 | 47.5 | 19 | 25 | 181 | 650 | 4027 5011 80 |
| 34 | 52 | 19 | 28 | 210 | 650 | 4027 5011 81 |
| 36 | 54 | 19 | 28 | 203 | 700 | 4027 5011 82 |
| 41 | 60 | 20 | 30 | 240 | 750 | 4027 5011 83 |
| 1/2 | 30 | 11 | 25 | 134 | 100 | 4027 5010 70 |
| 9/16 | 30 | 11 | 25 | 133 | 110 | 4027 5010 71 |
| 5/8 | 30 | 12 | 25 | 135 | 140 | 4027 5010 72 |
| 11/16 | 30 | 12 | 25 | 136 | 160 | 4027 5010 73 |
| 3/4 | 31 | 12 | 25 | 145 | 210 | 4027 5010 74 |
| 13/16 | 34 | 15 | 25 | 159 | 260 | 4027 5010 75 |
| 7/8 | 35 | 15 | 25 | 156 | 300 | 4027 5010 76 |

Bits Holders

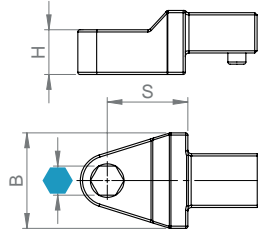

| | in | B mm | H mm | S mm | g | Ordering No. |
|---------|------|------|------|------|-----|--------------|
| 9 x 12 | 5/16 | 14 | 10 | 17.5 | 45 | 4027 5012 10 |
| | 1/4 | 16 | 12.5 | 17.5 | 47 | 4027 5012 11 |
| 14 x 18 | 5/16 | 16 | 12.5 | 25 | 112 | 4027 5012 13 |

Flared End

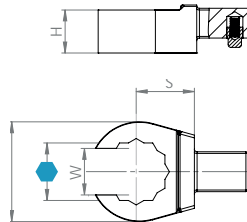

| | mm/in | B mm | H mm | S mm | W mm | g | Max Nm | Ordering No. |
|--------|-------|------|------|------|------|-----|--------------|--------------|
| 9 x 12 | 10 | 21.5 | 11 | 17.5 | 7.1 | 57 | 20 | 4027 5011 90 |
| | 11 | 22.5 | 11 | 17.5 | 8.6 | 55 | 25 | 4027 5011 91 |
| | 12 | 24.5 | 12 | 17.5 | 9 | 59 | 32 | 4027 5011 92 |
| | 13 | 26 | 13 | 17.5 | 10 | 55 | 40 | 4027 5011 93 |
| | 14 | 27 | 13 | 17.5 | 11 | 60 | 50 | 4027 5011 94 |
| | 15 | 27 | 13 | 17.5 | 12 | 60 | 50 | 4027 5011 95 |
| | 16 | 30.5 | 13 | 17.5 | 13 | 65 | 80 | 4027 5011 96 |
| | 17 | 31.5 | 13 | 17.5 | 14 | 64 | 82 | 4027 5011 97 |
| | 18 | 33 | 15 | 17.5 | 15 | 74 | 100 | 4027 5011 98 |
| | 19 | 34 | 15 | 17.5 | 16 | 80 | 115 | 4027 5011 99 |
| | 21 | 38.5 | 15 | 20 | 17 | 88 | 120 | 4027 5012 00 |
| | 22 | 39.5 | 15 | 20 | 17 | 92 | 120 | 4027 5012 01 |
| | 24 | 40 | 15 | 20 | 18 | 75 | 120 | 4027 5012 02 |
| | 27 | 45 | 17 | 25 | 20 | 120 | 140 | 4027 5012 03 |
| 3/8 | 18 | 8 | 17.5 | 7.1 | 39 | 20 | 4027 5010 30 | |
| 7/16 | 21 | 12 | 17.5 | 8.6 | 50 | 25 | 4027 5010 31 | |
| 1/2 | 26 | 13 | 17.5 | 10 | 61 | 32 | 4027 5010 32 | |
| 9/16 | 27 | 13 | 17.5 | 11 | 58 | 50 | 4027 5010 33 | |
| 5/8 | 30 | 13 | 17.5 | 14 | 62 | 80 | 4027 5010 34 | |
| 11/16 | 30 | 13 | 17.5 | 14 | 58 | 82 | 4027 5010 35 | |
| 3/4 | 34 | 15 | 17.5 | 15.8 | 71 | 115 | 4027 5010 36 | |

Hexagon Ratchet

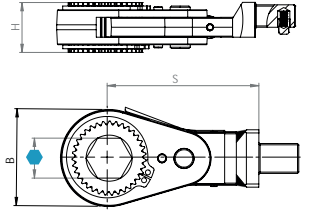

| | mm/in | B mm | H mm | S mm | g | Max Nm | Ordering No. |
|--------|-------|------|------|------|-----|--------|--------------|
| 9 x 12 | 10 | 28 | 13.5 | 51 | 95 | 25 | 4027 5012 30 |
| | 11 | 28 | 13.5 | 51 | 95 | 25 | 4027 5012 31 |
| | 12 | 28 | 13.5 | 51 | 95 | 25 | 4027 5012 32 |
| | 13 | 28 | 13.5 | 51 | 95 | 25 | 4027 5012 33 |
| | 14 | 32 | 16 | 56 | 140 | 35 | 4027 5012 34 |
| | 15 | 32 | 16 | 56 | 140 | 35 | 4027 5012 35 |
| | 16 | 39 | 20 | 61 | 205 | 70 | 4027 5012 36 |
| | 17 | 39 | 20 | 61 | 205 | 70 | 4027 5012 37 |
| | 18 | 39 | 20 | 61 | 205 | 70 | 4027 5012 38 |
| | 19 | 39 | 20 | 61 | 205 | 70 | 4027 5012 39 |
| | 21 | 45 | 23 | 61 | 290 | 85 | 4027 5012 40 |
| | 22 | 45 | 23 | 61 | 290 | 85 | 4027 5012 41 |
| | 24 | 45 | 23 | 61 | 290 | 85 | 4027 5012 42 |

Open Hexagon Ratchet

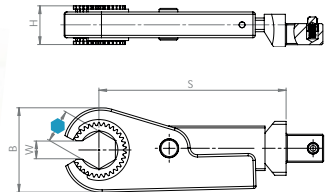

| | mm/in | B mm | H mm | S mm | W mm | g | Max Nm | Ordering No. | |
|--------|--------------------------------------|------|------|------|------|-----|--------|--------------|--|
| 9 x 12 | 8 | 30 | 16.5 | 48 | 5.1 | 90 | 15 | 4027 5012 50 | |
| | 9 | 30 | 16.5 | 48 | 6.3 | 90 | 15 | 4027 5012 51 | |
| | 10 | 30 | 16.5 | 48 | 6.3 | 89 | 15 | 4027 5012 52 | |
| | 11 | 30 | 16.5 | 48 | 6.3 | 89 | 15 | 4027 5012 53 | |
| | 12 | 36 | 16.5 | 81 | 7.1 | 200 | 18 | 4027 5012 54 | |
| | 13 | 36 | 16.5 | 81 | 7.6 | 200 | 18 | 4027 5012 55 | |
| | 14 | 36 | 16.5 | 81 | 8 | 200 | 18 | 4027 5012 56 | |
| | 15 | 44 | 20.5 | 83 | 9.1 | 280 | 45 | 4027 5012 57 | |
| | 16 | 44 | 20.5 | 83 | 9.6 | 280 | 45 | 4027 5012 58 | |
| | 17 | 44 | 20.5 | 83 | 10 | 280 | 45 | 4027 5012 59 | |
| | 18 | 44 | 20.5 | 83 | 10.5 | 280 | 45 | 4027 5012 60 | |
| | 19 | 44 | 20.5 | 83 | 10.5 | 280 | 45 | 4027 5012 61 | |
| | With reinforced bottom 9 x 12 | | | | | | | | |
| | 10 | 30 | 16.5 | 48 | 6.3 | 91 | 15 | 4027 5012 63 | |
| | 11 | 30 | 16.5 | 48 | 6.3 | 91 | 15 | 4027 5012 64 | |
| | 12 | 30 | 16.5 | 48 | 7.1 | 91 | 15 | 4027 5012 65 | |
| | 13 | 30 | 20.5 | 48 | 7.6 | 91 | 15 | 4027 5012 66 | |

End Fittings CWR

Mechanical Wrenches

Open End with Ratchet Function

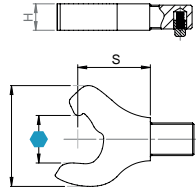

| | mm/in | B mm | H mm | S mm | g | Ordering No. |
|----------------|-------|------|------|------|-----|--------------|
| 9 x 12 | | | | | | |
| | 10 | 22.5 | 10 | 17.5 | 34 | 4027 5012 80 |
| | 11 | 24.5 | 10 | 21 | 39 | 4027 5012 81 |
| | 12 | 26.7 | 10 | 21 | 42 | 4027 5012 82 |
| | 13 | 30 | 10 | 23 | 49 | 4027 5012 83 |
| | 14 | 30.5 | 10 | 25.5 | 55 | 4027 5012 84 |
| | 15 | 32 | 10 | 27 | 60 | 4027 5012 85 |
| | 16 | 35 | 10 | 28 | 65 | 4027 5012 86 |
| | 17 | 37 | 10 | 29 | 68 | 4027 5012 87 |
| | 18 | 38 | 10 | 32.5 | 78 | 4027 5012 88 |
| | 19 | 41 | 10 | 33 | 90 | 4027 5012 89 |
| | 21 | 46.5 | 10 | 35 | 100 | 4027 5012 90 |
| | 22 | 46.5 | 10 | 35 | 97 | 4027 5012 91 |
| | 24 | 50 | 10 | 37.5 | 115 | 4027 5012 92 |
| | 27 | 57 | 10 | 47.5 | 156 | 4027 5012 93 |
| | 30 | 62 | 10 | 52.5 | 182 | 4027 5012 94 |
| | 32 | 67 | 12 | 52.5 | 234 | 4027 5012 95 |
| 14 x 18 | | | | | | |
| | 17 | 37 | 16 | 28 | 125 | 4027 5012 98 |
| | 18 | 41 | 16 | 32 | 12 | 4027 5012 99 |
| | 19 | 41 | 16 | 32.5 | 130 | 4027 5013 00 |
| | 21 | 46.5 | 16 | 35 | 150 | 4027 5013 01 |
| | 27 | 46.5 | 16 | 40 | 198 | 4027 5013 02 |
| | 15 | 50 | 16 | 41 | 220 | 4027 5013 03 |
| | 16 | 58 | 16 | 43.5 | 270 | 4027 5013 04 |
| | 17 | 63 | 16 | 52 | 310 | 4027 5013 05 |
| | 24 | 66 | 16 | 59 | 336 | 4027 5013 06 |
| | 32 | 75 | 16 | 55 | 388 | 4027 5013 07 |

Setting Key



| | g | Ordering No. |
|-------------|-----|--------------|
| Setting key | 169 | 4027 5014 00 |

Blank End



| | B mm | H mm | S mm | g | Ordering No. |
|----------------|------|------|------|----|--------------|
| 9 x 12 | | | | | |
| | 23 | 14 | 9 | 30 | 4027 5012 20 |
| Assembled | 23 | 14 | 9 | 30 | 4027 5012 21 |
| 14 x 18 | | | | | |
| | 30 | 21 | 13 | 98 | 4027 5012 23 |
| Assembled | 30 | 21 | 13 | 98 | 4027 5012 24 |

Fixed Square

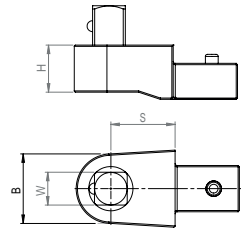

| | in | B mm | H mm | S mm | g | Max Nm | Ordering No. |
|----------------|-----|------|------|------|-----|--------|--------------|
| 9 x 12 | | | | | | | |
| | 1/4 | 20 | 14 | 17.5 | 76 | 40 | 4027 5013 20 |
| | 3/8 | 20 | 14 | 17.5 | 82 | 80 | 4027 5013 21 |
| | 1/2 | 20 | 14 | 17.5 | 71 | 100 | 4027 5013 22 |
| 14 x 18 | | | | | | | |
| | 1/2 | 27 | 18 | 25 | 203 | 300 | 4027 5013 24 |
| | 3/4 | 40 | 25 | 25 | 396 | 650 | 4027 5013 25 |

Non-Reversible Ratchet End

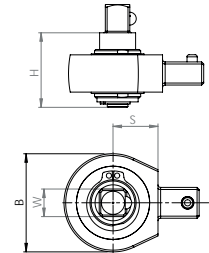

| | in | B mm | H mm | S mm | g | Max Nm | Ordering No. |
|----------------|-----|------|------|------|-----|--------|--------------|
| 9 x 12 | | | | | | | |
| | 3/8 | 38 | 29.5 | 17.5 | 140 | 80 | 4027 5013 30 |
| | 1/2 | 38 | 29.5 | 17.5 | 180 | 100 | 4027 5013 31 |
| 14 x 18 | | | | | | | |
| | 1/2 | 44 | 29.5 | 25 | 230 | 300 | 4027 5013 33 |

Reversible Ratchet End

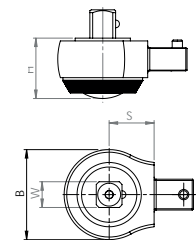

| | in | B mm | H mm | S mm | g | Max Nm | Ordering No. |
|----------------|-----|------|------|------|-----|--------|--------------|
| 9 x 12 | | | | | | | |
| | 1/4 | 27 | 27 | 17.5 | 68 | 50 | 4027 5013 40 |
| | 3/8 | 36.5 | 25 | 17.5 | 140 | 100 | 4027 5013 41 |
| | 1/2 | 33.5 | 37 | 17.5 | 150 | 120 | 4027 5013 42 |
| 14 x 18 | | | | | | | |
| | 1/2 | 41 | 26 | 25 | 320 | 300 | 4027 5013 44 |
| | 3/4 | 62 | 32 | 46 | 865 | 800 | 4027 5013 45 |

Reversible Ratchet End

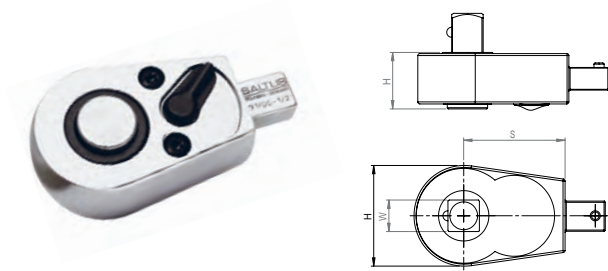

| | in | B mm | H mm | S mm | g | Max Nm | Ordering No. |
|----------------|-----|------|------|------|------|--------|--------------|
| 9 x 12 | 1/4 | 25 | 13.5 | 21.5 | 77 | 49 | 4027 5013 60 |
| | 3/8 | 33.5 | 17.5 | 30.5 | 160 | 100 | 4027 5013 61 |
| | 1/2 | 41.5 | 20.5 | 37.5 | 291 | 120 | 4027 5013 62 |
| 14 x 18 | 1/2 | 41.5 | 20.5 | 37.5 | 339 | 300 | 4027 5013 64 |
| | 3/4 | 63.5 | 31 | 70 | 1155 | 650 | 4027 5013 65 |

Connectors for Dovetails Inserts

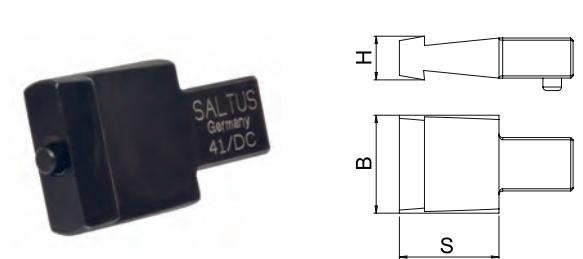

| | B mm | H mm | S mm | g | Ordering No. |
|----------------|------|------|------|----|--------------|
| 9 x 12 | 22 | 10 | 21.5 | 39 | 4027 5013 90 |
| 14 x 18 | 29 | 10 | 26.5 | 92 | 4027 5013 91 |

Ratchet Reversible with Hexagonal Output

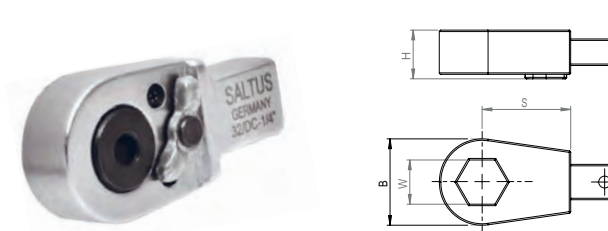

| | in | B mm | H mm | S mm | g | Max Nm | Ordering No. |
|---------------|------|------|------|------|-----|--------|--------------|
| 9 x 12 | 1/4 | 22 | 14 | 17.5 | 60 | 40 | 4027 5013 80 |
| | 5/16 | 29 | 14.5 | 28 | 117 | 80 | 4027 5013 81 |

Belknap Adapter



| | Type | S mm | g | Ordering No. |
|----------------|----------|------|-----|--------------|
| 9 x 12 | J-Shank | 24 | 68 | 4027 5016 90 |
| | Y-Shank | 29 | 71 | 4027 5016 91 |
| | X-Shank | 31 | 86 | 4027 5016 92 |
| | Z- Shank | 56 | 314 | 4027 5016 93 |
| 14 x 18 | J-Shank | 24 | 105 | 4027 5017 00 |
| | Y-Shank | 29 | 104 | 4027 5017 01 |
| | X-Shank | 31 | 121 | 4027 5017 02 |
| | Z- Shank | 56 | 349 | 4027 5017 03 |

Open End

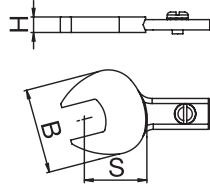

| mm/in | B mm | H mm | S mm | g | Max Nm | Ordering No. |
|------------------|---------|---------|---------|-----|-----------|--------------|
| BWR 20/35 | | | | | | |
| 7 | 24 | 5.5 | 17.5 | 23 | 13 | 4027 5000 00 |
| 8 | 24 | 5.5 | 17.5 | 25 | 13 | 4027 5000 01 |
| 9 | 24 | 5.5 | 17.5 | 25 | 13 | 4027 5000 02 |
| 10 | 30 | 6 | 24 | 31 | 20 | 4027 5000 03 |
| 11 | 30 | 6 | 24 | 31 | 24 | 4027 5000 04 |
| 12 | 33 | 6 | 25 | 31 | 29 | 4027 5000 05 |
| 13 | 33 | 6 | 25 | 34 | 40 | 4027 5000 06 |
| 14 | 33 | 6 | 25 | 34 | 45 | 4027 5000 07 |
| 15 | 35 | 6 | 28 | 34 | 45 | 4027 5000 08 |
| 16 | 35 | 7 | 28 | 50 | 50 | 4027 5000 09 |
| 17 | 38 | 7 | 30 | 60 | 60 | 4027 5000 10 |
| 18 | 38 | 7 | 31 | 60 | 65 | 4027 5000 11 |
| 19 | 38 | 7 | 31 | 60 | 70 | 4027 5000 12 |
| 21 | 43 | 7 | 35 | 61 | 95 | 4027 5000 13 |
| 22 | 43 | 7 | 35 | 61 | 95 | 4027 5000 14 |
| 24 | 46 | 10 | 35 | 61 | 95 | 4027 5000 15 |
| 27 | 46 | 10 | 40 | 61 | 95 | 4027 5000 16 |
| 1/4 | 24 | 5.5 | 17.5 | 23 | 13 | 4027 5006 50 |
| 5/16 | 24 | 5.5 | 17.5 | 25 | 13 | 4027 5006 51 |
| 3/8 | 24 | 5.5 | 17.5 | 25 | 13 | 4027 5006 52 |
| 7/16 | 30 | 6 | 24 | 31 | 24 | 4027 5006 53 |
| 1/2 | 33 | 6 | 25 | 34 | 40 | 4027 5006 54 |
| 9/16 | 35 | 6 | 28 | 34 | 45 | 4027 5006 55 |
| 5/8 | 35 | 7 | 28 | 50 | 50 | 4027 5006 56 |
| 11/16 | 38 | 7 | 31 | 60 | 65 | 4027 5006 57 |
| 3/4 | 38 | 7 | 31 | 60 | 70 | 4027 5006 58 |
| BWR 100 | | | | | | |
| 13 | 40 | 7.5 | 25 | 75 | 45 | 4027 5000 30 |
| 14 | 40 | 7.5 | 25 | 75 | 45 | 4027 5000 31 |
| 15 | 40 | 7.5 | 25 | 75 | 50 | 4027 5000 32 |
| 16 | 45 | 10 | 28 | 90 | 55 | 4027 5000 33 |
| 17 | 45 | 10 | 28 | 110 | 65 | 4027 5000 34 |
| 18 | 45 | 10 | 28 | 110 | 65 | 4027 5000 35 |
| 19 | 45 | 10 | 28 | 115 | 75 | 4027 5000 36 |
| 21 | 46 | 10 | 32 | 115 | 75 | 4027 5000 37 |
| 22 | 46 | 10 | 32 | 115 | 80 | 4027 5000 38 |
| 24 | 46 | 10 | 32 | 120 | 100 | 4027 5000 39 |
| 27 | 55 | 10 | 36 | 120 | 100 | 4027 5000 40 |
| 1/2 | 40 | 7.5 | 25 | 75 | 45 | 4027 5006 70 |
| 9/16 | 40 | 7.5 | 25 | 75 | 50 | 4027 5006 71 |
| 5/8 | 45 | 10 | 28 | 90 | 55 | 4027 5006 72 |
| 11/16 | 45 | 10 | 28 | 110 | 65 | 4027 5006 73 |
| 3/4 | 45 | 10 | 28 | 115 | 75 | 4027 5006 74 |
| 13/16 | 46 | 10 | 32 | 115 | 75 | 4027 5006 75 |
| 7/8 | 46 | 10 | 32 | 115 | 80 | 4027 5006 76 |
| 15/16 | 46 | 10 | 32 | 120 | 100 | 4027 5006 77 |
| 1 | 55 | 10 | 36 | 120 | 100 | 4027 5006 78 |
| 1 1/8 | 61 | 12 | 43 | 227 | 130 | 4027 5006 79 |

Continued....

| mm/in | B mm | H mm | S mm | g | Max Nm | Ordering No. |
|----------------------|---------|---------|---------|------|-----------|--------------|
| BWR 240 | | | | | | |
| 16 | 53 | 10 | 34 | 210 | 85 | 4027 5000 60 |
| 17 | 53 | 10 | 44 | 210 | 85 | 4027 5000 61 |
| 18 | 53 | 10 | 44 | 210 | 85 | 4027 5000 62 |
| 19 | 53 | 10 | 44 | 210 | 85 | 4027 5000 63 |
| 21 | 60 | 10 | 46 | 210 | 85 | 4027 5000 64 |
| 22 | 60 | 13 | 48 | 290 | 170 | 4027 5000 65 |
| 24 | 61 | 13 | 41 | 350 | 175 | 4027 5000 66 |
| 27 | 64 | 15 | 50 | 360 | 180 | 4027 5000 67 |
| 5/8 | 53 | 10 | 34 | 210 | 85 | 4027 5006 90 |
| 11/16 | 53 | 10 | 44 | 210 | 85 | 4027 5006 91 |
| 3/4 | 53 | 10 | 44 | 210 | 85 | 4027 5006 92 |
| 13/16 | 60 | 10 | 46 | 210 | 85 | 4027 5006 93 |
| 7/8 | 60 | 13 | 48 | 290 | 170 | 4027 5006 94 |
| 15/16 | 63 | 14 | 59 | 480 | 360 | 4027 5006 95 |
| 1 | 72 | 15 | 60 | 580 | 440 | 4027 5006 96 |
| 1 1/8 | 75 | 15 | 60 | 595 | 440 | 4027 5006 97 |
| BWR 440 | | | | | | |
| 17 | 55 | 12 | 58 | 375 | 190 | 4027 5000 90 |
| 18 | 55 | 12 | 58 | 375 | 190 | 4027 5000 91 |
| 19 | 55 | 12 | 58 | 375 | 190 | 4027 5000 92 |
| 21 | 62 | 12 | 59 | 440 | 280 | 4027 5000 93 |
| 22 | 62 | 12 | 59 | 440 | 280 | 4027 5000 94 |
| 24 | 63 | 14 | 59 | 480 | 360 | 4027 5000 95 |
| 27 | 72 | 15 | 60 | 580 | 440 | 4027 5000 96 |
| 30 | 75 | 15 | 60 | 595 | 440 | 4027 5000 97 |
| 32 | 78 | 15 | 60 | 650 | 440 | 4027 5000 98 |
| 34 | 82 | 17 | 60 | 670 | 440 | 4027 5000 99 |
| 36 | 82 | 17 | 62 | 670 | 440 | 4027 5001 00 |
| 41 | 87 | 20 | 62 | 685 | 440 | 4027 5001 01 |
| 5/8 | 55 | 12 | 58 | 375 | 190 | 4027 5007 10 |
| 11/16 | 55 | 12 | 58 | 375 | 190 | 4027 5007 11 |
| 3/4 | 55 | 12 | 58 | 375 | 190 | 4027 5007 12 |
| 13/16 | 62 | 12 | 59 | 440 | 280 | 4027 5007 13 |
| 7/8 | 62 | 12 | 59 | 440 | 280 | 4027 5007 14 |
| 15/16 | 63 | 14 | 59 | 480 | 360 | 4027 5007 15 |
| 1 | 72 | 15 | 60 | 580 | 440 | 4027 5007 16 |
| BWR 750 | | | | | | |
| 21 | 62 | 12 | 58 | 600 | 300 | 4027 5001 20 |
| 22 | 62 | 12 | 58 | 600 | 300 | 4027 5001 21 |
| 24 | 70 | 14 | 58 | 620 | 320 | 4027 5001 22 |
| 27 | 75 | 15 | 58 | 700 | 360 | 4027 5001 23 |
| 30 | 80 | 15 | 58 | 820 | 420 | 4027 5001 24 |
| 32 | 82 | 17 | 58 | 850 | 490 | 4027 5001 25 |
| 34 | 86 | 17 | 62 | 860 | 570 | 4027 5001 26 |
| 36 | 86 | 17 | 62 | 860 | 570 | 4027 5001 27 |
| 41 | 92 | 20 | 64 | 950 | 620 | 4027 5001 28 |
| 46 | 97 | 22 | 66 | 980 | 630 | 4027 5001 29 |
| 13/16 | 62 | 12 | 58 | 600 | 300 | 4027 5007 30 |
| 7/8 | 62 | 12 | 58 | 600 | 300 | 4027 5007 31 |
| 15/16 | 70 | 14 | 58 | 620 | 320 | 4027 5007 32 |
| 1 | 75 | 15 | 58 | 700 | 360 | 4027 5007 33 |
| 1 1/8 | 80 | 15 | 58 | 820 | 420 | 4027 5007 34 |
| BWR 1300/2000 | | | | | | |
| 24 | 70 | 14 | 53 | 950 | 350 | 4027 5001 50 |
| 27 | 75 | 15 | 53 | 960 | 480 | 4027 5001 51 |
| 30 | 82 | 17 | 53 | 1050 | 600 | 4027 5001 52 |
| 32 | 82 | 17 | 61 | 1150 | 750 | 4027 5001 53 |
| 34 | 86 | 18 | 64 | 1200 | 890 | 4027 5001 54 |
| 36 | 86 | 18 | 65 | 1200 | 890 | 4027 5001 55 |
| 41 | 92 | 20 | 77 | 1650 | 1150 | 4027 5001 56 |
| 46 | 97 | 22 | 80 | 1800 | 1450 | 4027 5001 57 |
| 50 | 104 | 22 | 82 | 1900 | 1750 | 4027 5001 58 |
| 55 | 110 | 22 | 83 | 1985 | 1800 | 4027 5001 59 |
| 60 | 115 | 22 | 86 | 2000 | 1850 | 4027 5001 60 |
| 75 | 170 | 25 | 113 | 3500 | 2000 | 4027 5001 61 |
| 15/16 | 70 | 14 | 53 | 950 | 350 | 4027 5007 40 |
| 1 | 75 | 15 | 53 | 960 | 480 | 4027 5007 41 |
| 1 1/8 | 82 | 17 | 53 | 1050 | 600 | 4027 5007 42 |

Box End

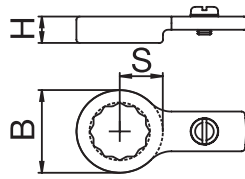

| mm/in | B mm | H mm | S mm | g | Max Nm | Ordering No. |
|------------------|---------|---------|---------|-----|-----------|--------------|
| BWR 20/35 | | | | | | |
| 7 | 16 | 6 | 8 | 20 | 25 | 4027 5001 80 |
| 8 | 16 | 6 | 8 | 20 | 25 | 4027 5001 81 |
| 9 | 18 | 6 | 9 | 20 | 32 | 4027 5001 82 |
| 10 | 19 | 7 | 9.5 | 22 | 38 | 4027 5001 83 |
| 11 | 20 | 7 | 10 | 25 | 50 | 4027 5001 84 |
| 12 | 21 | 7 | 10.5 | 25 | 60 | 4027 5001 85 |
| 13 | 22 | 8 | 11 | 28 | 75 | 4027 5001 86 |
| 14 | 23 | 8 | 11.5 | 30 | 85 | 4027 5001 87 |
| 15 | 25 | 8 | 12.5 | 32 | 85 | 4027 5001 88 |
| 16 | 27 | 8 | 13.5 | 35 | 85 | 4027 5001 89 |
| 17 | 27 | 8 | 13.5 | 35 | 85 | 4027 5001 90 |
| 18 | 29 | 8 | 14.5 | 36 | 85 | 4027 5001 91 |
| 19 | 29 | 8 | 14.5 | 36 | 85 | 4027 5001 92 |
| 21 | 34 | 10 | 16 | 40 | 85 | 4027 5001 93 |
| 22 | 34 | 10 | 17 | 40 | 85 | 4027 5001 94 |
| 24 | 37 | 10 | 18.5 | 40 | 85 | 4027 5001 95 |
| 1/4 | 16 | 6 | 8 | 20 | 25 | 4027 5007 50 |
| 5/16 | 16 | 6 | 8 | 20 | 25 | 4027 5007 51 |
| 3/8 | 18 | 6 | 9 | 20 | 32 | 4027 5007 52 |
| 7/16 | 20 | 7 | 10 | 25 | 50 | 4027 5007 53 |
| 1/2 | 22 | 8 | 11 | 28 | 75 | 4027 5007 54 |
| 9/16 | 25 | 8 | 12.5 | 32 | 85 | 4027 5007 55 |
| 5/8 | 27 | 8 | 13.5 | 35 | 85 | 4027 5007 56 |
| 11/16 | 29 | 8 | 14.5 | 36 | 85 | 4027 5007 57 |
| 3/4 | 29 | 8 | 14.5 | 36 | 85 | 4027 5007 58 |
| BWR 100 | | | | | | |
| 13 | 23 | 10 | 11.5 | 55 | 75 | 4027 5002 10 |
| 14 | 25 | 10 | 12.5 | 58 | 85 | 4027 5002 11 |
| 15 | 26 | 10 | 13 | 60 | 100 | 4027 5002 12 |
| 16 | 28 | 12 | 14 | 62 | 100 | 4027 5002 13 |
| 17 | 28 | 12 | 14 | 65 | 100 | 4027 5002 14 |
| 18 | 30 | 12 | 15 | 68 | 100 | 4027 5002 15 |
| 19 | 30 | 12 | 15 | 70 | 100 | 4027 5002 16 |
| 21 | 32 | 12 | 16 | 70 | 100 | 4027 5002 17 |
| 22 | 34 | 12 | 17 | 72 | 100 | 4027 5002 18 |
| 24 | 37 | 14 | 18.5 | 90 | 100 | 4027 5002 19 |
| 1/2 | 23 | 10 | 11.5 | 55 | 75 | 4027 5007 70 |
| 9/16 | 26 | 10 | 13 | 60 | 100 | 4027 5007 71 |
| 5/8 | 28 | 12 | 14 | 62 | 100 | 4027 5007 72 |
| 11/16 | 30 | 12 | 15 | 68 | 100 | 4027 5007 73 |
| 3/4 | 30 | 12 | 15 | 70 | 100 | 4027 5007 74 |
| 13/16 | 32 | 12 | 16 | 70 | 100 | 4027 5007 75 |
| 7/8 | 34 | 12 | 17 | 72 | 100 | 4027 5007 76 |
| 15/16 | 37 | 14 | 18.5 | 90 | 100 | 4027 5007 77 |
| 1 | 40 | 12 | 24.5 | 100 | 100 | 4027 5007 78 |

Continued....

| mm/in | B mm | H mm | S mm | g | Max Nm | Ordering No. |
|----------------------|---------|---------|---------|------|-----------|--------------|
| BWR 240 | | | | | | |
| 16 | 33 | 12 | 31 | 190 | 135 | 4027 5002 40 |
| 17 | 33 | 12 | 31 | 190 | 135 | 4027 5002 41 |
| 18 | 33 | 12 | 31 | 195 | 150 | 4027 5002 42 |
| 19 | 33 | 12 | 31 | 195 | 150 | 4027 5002 43 |
| 21 | 38 | 12 | 31 | 210 | 200 | 4027 5002 44 |
| 22 | 38 | 12 | 31 | 210 | 200 | 4027 5002 45 |
| 24 | 40 | 14 | 31 | 210 | 240 | 4027 5002 46 |
| 27 | 44 | 14 | 31 | 225 | 240 | 4027 5002 47 |
| 5/8 | 33 | 12 | 31 | 190 | 135 | 4027 5007 90 |
| 11/16 | 33 | 12 | 31 | 195 | 150 | 4027 5007 91 |
| 3/4 | 33 | 12 | 31 | 195 | 150 | 4027 5007 92 |
| 13/16 | 38 | 12 | 31 | 210 | 200 | 4027 5007 93 |
| 7/8 | 38 | 12 | 31 | 210 | 200 | 4027 5007 94 |
| 15/16 | 40 | 14 | 31 | 210 | 240 | 4027 5007 95 |
| 1 | 44 | 14 | 31 | 225 | 240 | 4027 5007 96 |
| BWR 440 | | | | | | |
| 17 | 36 | 12 | 56 | 300 | 190 | 4027 5002 70 |
| 18 | 36 | 12 | 56 | 300 | 190 | 4027 5002 71 |
| 19 | 40 | 12 | 56 | 300 | 190 | 4027 5002 72 |
| 21 | 40 | 14 | 56 | 315 | 280 | 4027 5002 73 |
| 22 | 40 | 14 | 56 | 315 | 280 | 4027 5002 74 |
| 24 | 43 | 14 | 56 | 320 | 420 | 4027 5002 75 |
| 27 | 47 | 14 | 56 | 335 | 440 | 4027 5002 76 |
| 30 | 52 | 14 | 56 | 335 | 440 | 4027 5002 77 |
| 32 | 54 | 14 | 56 | 365 | 440 | 4027 5002 78 |
| 34 | 58 | 15 | 56 | 375 | 440 | 4027 5002 79 |
| 36 | 60 | 15 | 56 | 385 | 440 | 4027 5002 80 |
| 41 | 62 | 15 | 56 | 395 | 440 | 4027 5002 81 |
| 44 | 72 | 16 | 56 | 483 | 460 | 4027 5002 82 |
| 5/8 | 36 | 12 | 56 | 300 | 190 | 4027 5008 10 |
| 11/16 | 36 | 12 | 56 | 300 | 190 | 4027 5008 11 |
| 3/4 | 40 | 12 | 56 | 300 | 190 | 4027 5008 12 |
| 13/16 | 40 | 14 | 56 | 315 | 280 | 4027 5008 13 |
| 7/8 | 40 | 14 | 56 | 315 | 280 | 4027 5008 14 |
| 15/16 | 43 | 14 | 56 | 320 | 420 | 4027 5008 15 |
| 1 | 47 | 14 | 56 | 335 | 440 | 4027 5008 16 |
| BWR 750 | | | | | | |
| 21 | 40 | 14 | 58 | 450 | 320 | 4027 5003 00 |
| 22 | 40 | 14 | 58 | 470 | 320 | 4027 5003 01 |
| 24 | 43 | 14 | 58 | 500 | 480 | 4027 5003 02 |
| 27 | 47 | 16 | 58 | 520 | 480 | 4027 5003 03 |
| 30 | 54 | 16 | 58 | 535 | 700 | 4027 5003 04 |
| 32 | 56 | 16 | 58 | 565 | 750 | 4027 5003 05 |
| 34 | 60 | 19 | 58 | 575 | 750 | 4027 5003 06 |
| 36 | 60 | 19 | 58 | 575 | 750 | 4027 5003 07 |
| 38 | 60 | 19 | 58 | 565 | 750 | 4027 5003 08 |
| 41 | 65 | 19 | 58 | 585 | 750 | 4027 5003 09 |
| 46 | 69 | 19 | 58 | 600 | 750 | 4027 5003 10 |
| 13/16 | 40 | 14 | 58 | 450 | 320 | 4027 5008 30 |
| 7/8 | 40 | 14 | 58 | 470 | 320 | 4027 5008 31 |
| 15/16 | 43 | 14 | 58 | 500 | 480 | 4027 5008 32 |
| 1 | 47 | 16 | 58 | 520 | 480 | 4027 5008 33 |
| BWR 1300/2000 | | | | | | |
| 24 | 52 | 18 | 58 | 750 | 520 | 4027 5003 30 |
| 27 | 56 | 18 | 58 | 760 | 560 | 4027 5003 31 |
| 30 | 60 | 18 | 58 | 800 | 740 | 4027 5003 32 |
| 32 | 62 | 18 | 58 | 820 | 950 | 4027 5003 33 |
| 34 | 62 | 18 | 58 | 850 | 1200 | 4027 5003 34 |
| 36 | 70 | 18 | 58 | 850 | 1200 | 4027 5003 35 |
| 41 | 70 | 18 | 58 | 940 | 1800 | 4027 5003 36 |
| 46 | 78 | 20 | 58 | 1080 | 2000 | 4027 5003 37 |
| 50 | 85 | 22 | 58 | 1180 | 2000 | 4027 5003 38 |
| 55 | 90 | 22 | 58 | 1250 | 2000 | 4027 5003 39 |
| 60 | 95 | 22 | 58 | 1300 | 2000 | 4027 5003 40 |
| 15/16 | 52 | 18 | 58 | 750 | 520 | 4027 5008 40 |
| 1 | 56 | 18 | 58 | 760 | 560 | 4027 5008 41 |

End Fittings BWR

Mechanical Wrenches

Flared End



| | B | H | S | W | Max | Ordering No. |
|------------------|------|----|-------|------|-----|-----------------|
| mm/in | mm | mm | mm | mm | Nm | |
| BWR 20/35 | | | | | | |
| 8 | 18 | 6 | 9 | 6 | 20 | 16 4027 5003 60 |
| 10 | 21 | 7 | 10.5 | 7 | 25 | 16 4027 5003 61 |
| 11 | 21 | 7 | 10.5 | 8.5 | 25 | 20 4027 5003 62 |
| 12 | 25 | 9 | 12.5 | 9 | 32 | 25 4027 5003 63 |
| 13 | 25 | 8 | 12.5 | 10 | 32 | 25 4027 5003 64 |
| 14 | 25 | 8 | 12.5 | 11 | 32 | 25 4027 5003 65 |
| 15 | 29 | 8 | 14.5 | 11 | 35 | 25 4027 5003 66 |
| 17 | 31.5 | 10 | 15.75 | 14 | 35 | 50 4027 5003 67 |
| 19 | 34 | 10 | 17 | 15.8 | 40 | 50 4027 5003 68 |
| 21 | 34 | 10 | 17 | 17 | 42 | 50 4027 5003 69 |
| 22 | 34 | 10 | 17 | 17 | 45 | 50 4027 5003 70 |
| 24 | 38 | 14 | 20 | 18 | 60 | 60 4027 5003 71 |
| 3/8 | 21 | 7 | 12 | 8 | 25 | 16 4027 5008 50 |
| 7/16 | 21 | 7 | 12 | 8.5 | 25 | 20 4027 5008 51 |
| 1/2 | 25 | 8 | 14 | 10 | 32 | 25 4027 5008 52 |
| 9/16 | 29 | 8 | 14 | 11 | 35 | 25 4027 5008 53 |
| 5/8 | 31.5 | 10 | 16 | 14 | 35 | 50 4027 5008 54 |
| 11/16 | 34 | 10 | 17.5 | 15.8 | 40 | 50 4027 5008 55 |
| 3/4 | 34 | 10 | 18 | 17 | 40 | 50 4027 5008 56 |
| BWR 100 | | | | | | |
| 15/8 | 32 | 10 | 18.5 | 12 | 75 | 50 4027 5008 72 |
| 11/16 | 32 | 12 | 18.5 | 14 | 78 | 50 4027 5008 73 |
| 3/4 | 36 | 12 | 19.5 | 16 | 90 | 50 4027 5008 74 |

Hexagon Ratchet



| | B | H | S | Max | Ordering No. |
|------------------|----|------|----|-----|------------------|
| mm | mm | mm | mm | Nm | |
| BWR 20/35 | | | | | |
| 8 | 28 | 13.5 | 44 | 80 | 25 4027 5003 90 |
| 10 | 28 | 13.5 | 44 | 80 | 25 4027 5003 91 |
| 11 | 28 | 13.5 | 44 | 80 | 25 4027 5003 92 |
| 12 | 28 | 13.5 | 44 | 80 | 25 4027 5003 93 |
| 13 | 28 | 13.5 | 44 | 80 | 25 4027 5003 94 |
| 14 | 32 | 16 | 47 | 120 | 35 4027 5003 95 |
| 15 | 32 | 16 | 47 | 120 | 35 4027 5003 96 |
| 16 | 39 | 20 | 51 | 180 | 85 4027 5003 97 |
| 17 | 39 | 20 | 51 | 180 | 85 4027 5003 98 |
| 18 | 39 | 20 | 51 | 180 | 85 4027 5003 99 |
| 19 | 39 | 20 | 51 | 180 | 85 4027 5004 00 |
| 21 | 45 | 23 | 57 | 257 | 85 4027 5004 01 |
| 22 | 45 | 23 | 57 | 257 | 85 4027 5004 02 |
| BWR 100 | | | | | |
| 15 | 39 | 20 | 51 | 200 | 70 4027 5004 20 |
| 16 | 39 | 20 | 51 | 200 | 70 4027 5004 21 |
| 17 | 39 | 20 | 51 | 200 | 70 4027 5004 22 |
| 18 | 39 | 20 | 51 | 200 | 100 4027 5004 23 |
| 19 | 39 | 20 | 51 | 200 | 100 4027 5004 24 |

Open Hexagon Ratchet

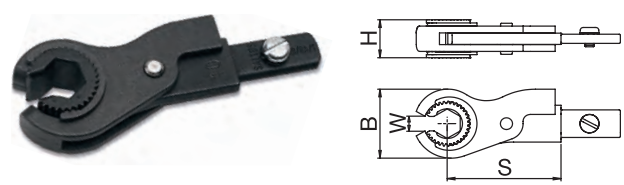

| | B | H | S | W | Max | Ordering No. |
|------------------|----|------|------|-----|-----|-----------------|
| mm/in | mm | mm | mm | mm | Nm | |
| BWR 20/35 | | | | | | |
| 8 | 30 | 16.5 | 48 | 5.1 | 85 | 15 4027 5004 50 |
| 9 | 30 | 16.5 | 48 | 5.6 | 85 | 15 4027 5004 51 |
| 10 | 30 | 16.5 | 48 | 6.3 | 85 | 15 4027 5004 52 |
| 11 | 30 | 16.5 | 48 | 6.3 | 85 | 15 4027 5004 53 |
| 12 | 36 | 16.5 | 81 | 7.1 | 190 | 18 4027 5004 54 |
| 13 | 36 | 16.5 | 81 | 7.6 | 190 | 18 4027 5004 55 |
| 14 | 36 | 16.5 | 81 | 8 | 190 | 18 4027 5004 56 |
| 17 | 42 | 20.5 | 73.5 | 10 | 260 | 18 4027 5004 57 |

Fixed Square End

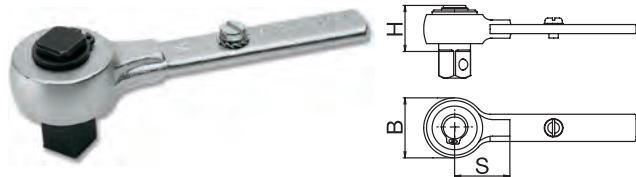

| | B | H | S | Max | Ordering No. |
|----------------------|----|----|----|------|-------------------|
| in x mm | mm | mm | mm | Nm | |
| BWR 20/35 | | | | | |
| 1/4x30 | 24 | 30 | 21 | 65 | 25 4027 5004 80 |
| 1/4x70 | 24 | 70 | 21 | 115 | 25 4027 5004 81 |
| 3/8x30 | 24 | 30 | 21 | 65 | 85 4027 5004 82 |
| 3/8x70 | 27 | 70 | 21 | 120 | 85 4027 5004 83 |
| 1/2x35 | 24 | 35 | 21 | 75 | 85 4027 5004 84 |
| 1/2x70 | 24 | 70 | 21 | 145 | 85 4027 5004 85 |
| BWR 100 | | | | | |
| 3/8x40 | 32 | 40 | 30 | 75 | 100 4027 5004 90 |
| 3/8x70 | 32 | 70 | 30 | 240 | 100 4027 5004 91 |
| 1/2x40 | 32 | 40 | 30 | 175 | 100 4027 5004 92 |
| 1/2x70 | 32 | 70 | 30 | 245 | 100 4027 5004 93 |
| BWR 240 | | | | | |
| 1/2x40 | 34 | 40 | 31 | 300 | 240 4027 5004 98 |
| 1/2x70 | 34 | 70 | 31 | 330 | 240 4027 5004 99 |
| BWR 440 | | | | | |
| 1/2x40 | 48 | 40 | 58 | 600 | 440 4027 5005 04 |
| 1/2x70 | 48 | 70 | 58 | 630 | 440 4027 5005 05 |
| 3/4x70 | 48 | 70 | 58 | 689 | 440 4027 5005 06 |
| BWR 750 | | | | | |
| 3/4x70 | 48 | 70 | 58 | 775 | 750 4027 5005 11 |
| BWR 1300/2000 | | | | | |
| 3/4x70 | 73 | 70 | 58 | 1400 | 1000 4027 5005 16 |
| 1x70 | 73 | 70 | 58 | 1700 | 2000 4027 5005 17 |

Ratchet End

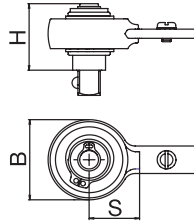

| in x mm | B mm | H mm | S mm | g | Max Nm | Ordering No. |
|----------------------|------|------|------|------|--------|--------------|
| BWR 20/35 | | | | | | |
| 1/4x40 | 36 | 40 | 21 | 145 | 25 | 4027 5005 25 |
| 1/4x70 | 38 | 70 | 21 | 165 | 25 | 4027 5005 26 |
| 3/8x40 | 36 | 40 | 21 | 145 | 85 | 4027 5005 27 |
| 3/8x70 | 36 | 70 | 21 | 170 | 85 | 4027 5005 28 |
| 1/2x45 | 36 | 45 | 21 | 150 | 85 | 4027 5005 29 |
| 1/2x70 | 36 | 70 | 21 | 195 | 85 | 4027 5005 30 |
| BWR 100 | | | | | | |
| 3/8x40 | 48 | 40 | 30 | 270 | 100 | 4027 5005 36 |
| 3/8x70 | 48 | 70 | 30 | 31 | 100 | 4027 5005 37 |
| 1/2x45 | 48 | 40 | 30 | 285 | 100 | 4027 5005 38 |
| 1/2x70 | 48 | 70 | 30 | 320 | 100 | 4027 5005 39 |
| BWR 240 | | | | | | |
| 1/2x45 | 48 | 45 | 31 | 300 | 240 | 4027 5005 44 |
| 1/2x70 | 48 | 70 | 31 | 330 | 240 | 4027 5005 45 |
| BWR 440 | | | | | | |
| 3/4x70 | 72 | 70 | 58 | 1100 | 440 | 4027 5005 50 |
| BWR 750 | | | | | | |
| 3/4x70 | 72 | 70 | 58 | 1250 | 750 | 4027 5005 55 |
| BWR 1300/2000 | | | | | | |
| 3/4x70 | 85 | 70 | 58 | 1700 | 1000 | 4027 5005 60 |
| 1x80 | 85 | 80 | 58 | 2000 | 2000 | 4027 5005 61 |

Belknap Adapter



| Type | S mm | g | Ordering No. |
|----------------------|------|-----|--------------|
| BWR 20/35 | | | |
| J-Shank | 24 | 68 | 4027 5009 50 |
| Y-Shank | 29 | 65 | 4027 5009 60 |
| BWR 100 | | | |
| J-Shank | 24 | 85 | 4027 5009 51 |
| Y-Shank | 29 | 82 | 4027 5009 61 |
| X-Shank | 31 | 100 | 4027 5009 70 |
| Z-Shank | 56 | 327 | 4027 5009 80 |
| BWR 240 | | | |
| Y-Shank | 29 | 193 | 4027 5009 62 |
| X-Shank | 31 | 211 | 4027 5009 71 |
| Z-Shank | 56 | 438 | 4027 5009 81 |
| BWR 440 | | | |
| Y-Shank | 29 | 279 | 4027 5009 63 |
| X-Shank | 31 | 297 | 4027 5009 72 |
| Z-Shank | 56 | 524 | 4027 5009 82 |
| BWR 750 | | | |
| X-Shank | 31 | 455 | 4027 5009 73 |
| Z-Shank | 56 | 686 | 4027 5009 83 |
| BWR 1300/2000 | | | |
| Z-Shank | 56 | 924 | 4027 5009 84 |

Reversible Ratchet End

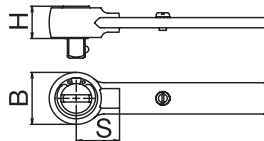

| in | B mm | H mm | S mm | g | Max Nm | Ordering No. |
|----------------------|------|------|------|------|--------|--------------|
| BWR 20/35 | | | | | | |
| 1/4 | 25 | 26 | 21 | 55 | 25 | 4027 5005 70 |
| 3/8 | 36 | 35 | 21 | 130 | 85 | 4027 5005 71 |
| 1/2 | 36 | 40 | 21 | 135 | 85 | 4027 5005 72 |
| BWR 100 | | | | | | |
| 3/8 | 36 | 35 | 30 | 165 | 100 | 4027 5005 77 |
| 1/2 | 36 | 40 | 30 | 175 | 100 | 4027 5005 78 |
| BWR 240 | | | | | | |
| 1/2 | 36 | 40 | 31 | 285 | 240 | 4027 5005 83 |
| BWR 440 | | | | | | |
| 3/4 | 68 | 56 | 58 | 1100 | 440 | 4027 5005 88 |
| BWR 750 | | | | | | |
| 3/4 | 68 | 70 | 58 | 1250 | 750 | 4027 5005 93 |
| BWR 1300/2000 | | | | | | |
| 3/4 | 68 | 70 | 58 | 1500 | 1000 | 4027 5005 98 |
| 1 | 68 | 70 | 58 | 1500 | 1000 | 4027 5005 99 |

Setting Key BWR



| | g | Ordering No. |
|--------------------------------|-----|--------------|
| Setting key BWR 20 up to 100 | 97 | 4027 5006 10 |
| Setting key BWR 240 | 164 | 4027 5006 11 |
| Setting key BWR 440 | 428 | 4027 5006 12 |
| Setting key BWR 750 up to 2000 | 603 | 4027 5006 13 |

Setting Key SWR



| | g | Ordering No. |
|-------------------------|-----|--------------|
| Setting-Key-Set SWR-30 | 94 | 4027 5030 00 |
| Setting-Key-Set SWR-60 | 171 | 4027 5030 01 |
| Setting-Key-Set SWR-110 | 429 | 4027 5030 02 |

Where the joints are critical

Critical fastening duties are among the most essential tightening operations within industry today. So whether you're in the business of assembling cars or trucks, tractors or harvesters, trains or planes, you need to be in control when it comes to production and quality assurance.

STWRENCH

The Atlas Copco STwrench is much more than a standard transducerized hand-held nutrunner. Due to its modular design, you can build the STwrench to meet your exact requirements and create a tool that perfectly matches your applications.

Use the STwrench for production to get full traceability of the entire tightening operation, including torque control, angle control and yield control. Or build your wrench to just tighten your joint with high torque accuracy. Or use it for quality control to check residual torque, to perform joint analysis, including joint behaviour and stiffness, to set the correct tightening parameters for production and to test the reproducibility of joint stiffness on the benches.

THE ULTIMATE WRENCH FOR PRODUCTION AND QUALITY ASSURANCE

With the STwrench you can build the functionality you need into your own tool. Choose three patented components – smartHEAD, RBU and the power supply solution to suit your exact requirements. Then add a fourth: the patented controller that is standard for all STwrenches. Due to the modular design of the STwrench, you can mix and match components to suit all types of applications.

Use it as a basic stand-alone system or integrate it with Atlas Copco hardware and software. The STwrench is versatile enough to tighten hard-to-reach bolts using a variety of torque and angle strategies while providing complete traceability. Yet it handles quality control of residual torque just as easily as it does comprehensive joint analysis.

SMARTHEAD

The smartHEAD has a built-in memory chip to store calibration values that are automatically recognized by the STwrench controller. Choose from six different sizes ranging from 30 to 600

Nm, which is connected to the controller by a patented system allowing a fast connection. It can be with or without Gyroscope and the torque transducer is made to guarantee length-independent reading. TAG recognition patented solution is used to assure Poka-Yoke operations. It includes at front a Led bright light to improve visibility in dark bolt area.

STWRENCH CONTROLLER

This is the brain of the wrench. It has a clear and visible display, LED ring, vibrating handle and buzzer for immediate feedback to the operator. It has dedicated slots where you can insert the RBU, one wireless module and the Bar Code Module (see Optional Accessories).

The STwrench Controller can be powered by a patented bi-energy solution such as the long life STwrench Battery or by Tensor SL connected to the Power Focus via the STwrench Cable Box.

STWRENCH RBU

Atlas Copco's patented Rapid Backup Unit (RBU) concept transfers functionality to a non-configured hardware unit, ensuring that hardware can easily be upgraded. The RBU also acts as back-up for programming and configuration. If a change of hardware is required, just fit the RBU to the new hardware, switch on the unit and you're ready. All programming and network configurations are transferred in seconds. The RBU cuts downtime to a minimum.

BLM API

The BLM API is a software tool that makes possible for a programmer to integrate in his own code the function to manage one or more STwrenches via cable or WiFi. Only STwrenches with API RBU can be connected.



| FUNCTIONALITY | QUALITY | | PRODUCTION | | FUNCTIONALITY | QUALITY | | PRODUCTION | |
|--|-----------|-------------|------------|-------------|---|-----------|-------------|------------|-------------|
| | SmartHEAD | smartHEAD A | smartHEAD | smartHEAD A | | SmartHEAD | smartHEAD A | smartHEAD | smartHEAD A |
| Controller | | | | | PSET | | | | |
| 360° LED lights on board for operator feedback | x | x | x | x | Number of Psets | 200 | 200 | 200 | 200 |
| Keyboard | x | x | x | x | Batch count | x | x | x | x |
| Graphic Display | x | x | x | x | Number of job | 100 | 100 | 100 | 100 |
| USB mini to connect ToolsTalk BLM | x | x | x | x | Number of multistage | 200 | 200 | 200 | 200 |
| Infrared communication | x | x | x | x | CW/CCW operation | x | x | x | x |
| Buzzer | x | x | x | x | Bending correction | | x | | x |
| Rapid Back Up Unit (RBU) | x | x | x | x | Extension torque correction | x | x | x | x |
| Vibration | x | x | x | x | Extension angle correction | | x | | x |
| Shock detector | x | x | x | x | | | | | |
| smartHEAD | | | | | General | | | | |
| Interchangeable head – Tag recognition | x | x | x | x | Transducer torque traceability | x | x | x | x |
| Light in front of smartHEAD | x | x | x | x | Result data storage | 5000 | 5000 | 5000 | 5000 |
| Gyroscope for angle measurement | | x | | x | Trace storage | 10 | 10 | 10 | 10 |
| Length-independent torque transducer | x | x | x | x | SPC | x | x | x | x |
| | | | | | Multi units (Nm, Kg/m) | x | x | x | x |
| | | | | | Multi language menu | x | x | x | x |
| | | | | | Interchangeable head – Tag recognition writing function | x | x | x | x |
| Free mode – programs | | | | | Connectivity | | | | |
| Track torque | x | x | x | x | PF connectivity for I/O or any type of fieldBus | x | x | x | x |
| Peak torque | x | x | x | x | ToolsNet | x | x | x | x |
| Residual check torque/time | x | x | x | x | QATnode | x | x | x | x |
| Residual check torque/angle | | x | | x | | | | | |
| Tightening torque with angle monitoring | | x | | x | | | | | |
| | | | | | Optional | | | | |
| Quality audit | | | | | Barcode Reader | | | | |
| Peak | x | x | x | x | IRC-W | x | x | x | x |
| Residual Check Torque/Time | x | x | x | x | IRC-B for Power Focus connectivity | x | x | x | x |
| Residual Check Torque/Angle | | x | | x | QATnode | x | x | x | x |
| Loosen And Retighten | | x | | x | | | | | |
| Loosen | | x | | x | ToolsTalk BLM | | | | |
| | | | | | USB Connection | x | x | x | x |
| Joint Analysis | | | | | Off Line programming | | | | |
| Torque/angle graphing | | x | | x | Tightening Database to PC (Excel) | x | x | x | x |
| Yield point detection | | x | | x | View trace | x | x | x | x |
| | | | | | Export trace in several formats | x | x | x | x |
| Tightening | | | | | Overlay Traces | | | | |
| Torque with time monitoring | | | x | x | Trace zoom | x | x | x | x |
| Torque with angle monitoring | | | | x | Statistical analysis | x | x | x | x |
| Torque plus angle | | | | x | Bar code reader configuration | x | x | x | x |
| Yield | | | | x | | | | | |
| Yield plus angle | | | | x | | | | | |

SMARTHEADS AND CONTROLLER

Square connection smartHEAD have been added to the range of smartHEADs. The square connection smartHEADs allow customers to use any square end fitting, losing thought the poka yoke system offered by end fittings in this catalogue.

BI controller is the new controller with the battery inserted in the STwrench handle. New batteries are to be used only in this controller. Recharge these batteries using standard battery charger with BI battery charger adapter.



STwrench

HOW TO ORDER YOUR STWRENCH

1. Take the STwrench Controller
2. Select your smartHEAD
3. Select your End fitting tool
4. Select your RBU
5. Select the Battery
6. Select if you want optional modules

| Model | Torque range | | Drive mm | Weight | | Length mm | Ordering No. |
|--------------------------------------|--------------|---------|----------|--------|------|-----------|--------------|
| | Nm | ft lb | | kg | lb | | |
| Controller | | | | | | | |
| STwrench Controller | | | | 0.48 | 1.08 | 313 | 8059 0930 00 |
| STwrench Controller BI | | | | 0.46 | 1.01 | 333 | 8059 0930 01 |
| smartHEAD only Torque | | | | | | | |
| smartHEAD 30 | 6-30 | 4.5-22 | 9x12 | 0.20 | 0.44 | 167.5 | 8059 0920 31 |
| smartHEAD 80 | 16-80 | 12-59 | 9x12 | 0.22 | 0.48 | 167.5 | 8059 0920 43 |
| smartHEAD 150 | 30-150 | 23-111 | 14x18 | 0.55 | 1.21 | 271.0 | 8059 0920 48 |
| smartHEAD 250 | 50-250 | 37-184 | 14x18 | 0.78 | 1.72 | 417.0 | 8059 0920 54 |
| smartHEAD 400 | 80-400 | 59-295 | 14x18 | 0.93 | 2.05 | 584.0 | 8059 0920 60 |
| smartHEAD 600 | 120-600 | 89-443 | 21x26 | 1.70 | 3.75 | 1048.5 | 8059 0920 66 |
| smartHEAD 1000 | 300-1000 | 148-737 | 28 | 1.90 | 4.19 | 1344 | 8059 0920 80 |
| smartHEAD A Torque + Angle | | | | | | | |
| smartHEAD A15 | 3-15 | 2.2-11 | 9x12 | 0.19 | 0.42 | 147.5 | 8059 0930 24 |
| smartHEAD A30 | 6-30 | 4.5-22 | 9x12 | 0.19 | 0.42 | 147.5 | 8059 0930 31 |
| smartHEAD A80 | 16-80 | 12-59 | 9x12 | 0.20 | 0.44 | 147.5 | 8059 0930 43 |
| smartHEAD A150 | 30-150 | 23-111 | 14x18 | 0.57 | 1.25 | 271.0 | 8059 0930 48 |
| smartHEAD A250 | 50-250 | 37-184 | 14x18 | 0.80 | 1.76 | 417.0 | 8059 0930 54 |
| smartHEAD A400 | 80-400 | 59-295 | 14x18 | 0.95 | 2.09 | 584.0 | 8059 0930 60 |
| smartHEAD A600 | 120-600 | 89-443 | 21x26 | 1.72 | 3.79 | 1048.5 | 8059 0930 66 |
| smartHEAD A800 | 160-800 | 118-590 | 21x26 | 1.70 | 3.75 | 1048.5 | 8059 0988 26 |
| smartHEAD A1000 | 300-1000 | 148-737 | 28 | 1.90 | 4.19 | 1344 | 8059 0930 80 |
| smartHEAD A Torque + Angle sq | | | | | | | |
| smartHEAD Asq15 | 3-15 | 2.2-11 | 9x12 | 0.19 | 0.42 | 147.5 | 8059 0930 28 |
| smartHEAD Asq30 | 6-30 | 4.5-22 | 9x12 | 0.19 | 0.42 | 147.5 | 8059 0930 32 |
| smartHEAD Asq80 | 16-80 | 12-59 | 9x12 | 0.20 | 0.44 | 147.5 | 8059 0930 44 |
| smartHEAD Asq150 | 30-150 | 23-111 | 14x18 | 0.55 | 1.21 | 271.0 | 8059 0930 50 |
| smartHEAD Asq250 | 50-250 | 37-184 | 14x18 | 0.78 | 1.72 | 417.0 | 8059 0930 56 |
| smartHEAD Asq400 | 80-400 | 59-295 | 14x18 | 0.93 | 2.05 | 584.0 | 8059 0930 62 |
| RBU Rapid Backup unit | | | | | | | |
| STwrench RBU Quality | | | | | | | 8059 0930 90 |
| STwrench RBU Production | | | | | | | 8059 0930 91 |
| STwrench RBU Quality API | | | | | | | 8059 0930 93 |
| STwrench RBU Production API | | | | | | | 8059 0930 92 |
| Battery | | | | | | | |
| STwrench battery | | | | | | | 8059 0930 86 |
| STwrench battery BI | | | | | | | 8059 0930 85 |
| STwrench battery HD | | | | | | | 8059 0930 83 |

SOFTWARE TT BLM W09

| | Ordering No. |
|-----------------|--------------|
| 1 user license | 8059 0981 10 |
| 5 user license | 8059 0981 11 |
| 10 user license | 8059 0981 12 |
| Plant license | 8059 0981 13 |

Dimensions

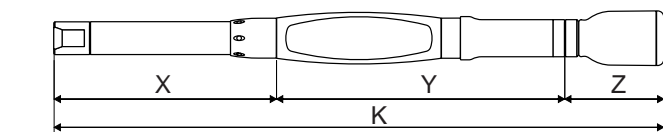

STwrench

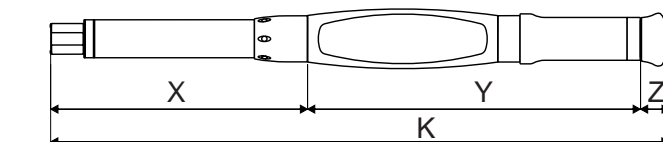

STwrench BI

| Model | Length | | | | Total weight | |
|---------------------|--------|------|------|------|--------------|------|
| | X mm | Y mm | Z mm | K mm | kg | lb |
| STwrench 15 Nm | 139 | 280 | 96 | 515 | 1.00 | 2.20 |
| STwrench 30 Nm | 139 | 280 | 96 | 515 | 1.03 | 2.27 |
| STwrench 80 Nm | 139 | 280 | 96 | 515 | 1.06 | 2.34 |
| STwrench 150 Nm | 262 | 280 | 96 | 638 | 1.28 | 2.82 |
| STwrench 250 Nm | 408 | 280 | 96 | 784 | 1.51 | 2.33 |
| STwrench 400 Nm | 575 | 280 | 96 | 951 | 1.71 | 2.77 |
| STwrench 600 Nm | 1040 | 280 | 96 | 1416 | 2.87 | 6.33 |
| STwrench 800 Nm | 1040 | 280 | 96 | 1416 | 2.87 | 6.33 |
| STwrench 1000 Nm | 1270 | 280 | 96 | 1646 | 3.72 | 8.20 |
| STwrench BI 15 Nm | 139 | 280 | 32 | 441 | 0.80 | 1.76 |
| STwrench BI 30 Nm | 139 | 280 | 32 | 441 | 0.83 | 1.83 |
| STwrench BI 80 Nm | 139 | 280 | 32 | 441 | 0.86 | 1.89 |
| STwrench BI 150 Nm | 262 | 280 | 32 | 564 | 1.08 | 2.38 |
| STwrench BI 250 Nm | 408 | 280 | 32 | 710 | 1.31 | 2.89 |
| STwrench BI 400 Nm | 576 | 280 | 32 | 877 | 1.51 | 3.33 |
| STwrench BI 600 Nm | 1040 | 280 | 32 | 1341 | 2.67 | 5.89 |
| STwrench BI 800 Nm | 1040 | 280 | 32 | 1341 | 2.67 | 5.89 |
| STwrench BI 1000 Nm | 1270 | 280 | 32 | 1571 | 3.52 | 7.76 |

X. – smartHEAD, Y. – STwrench Controller, Z. – Battery, K. – Total length

IRC MODULES

Two different IRC modules each with different wireless technology. No extra special software is needed, it is necessary only to plug in the new module to activate the communication. The communication can be to the Power Focus, to the QAT node, to the STwrench cradles or to different systems on the net.

BAR CODE MODULE

Enables the Bar Code to be read. STwrench is able to handle four different Bar Codes that can be used to activate or control the process and for traceability purposes. It is only necessary to plug in the module to activate the function.

STWRENCH BATTERY

All batteries are lithium ion ones. The standard battery gives up to 16 h of working time (10 h if wireless communication is used). BI and HD batteries have a working time of 6 h (4 h with wireless communication). Use the standard or the HD battery with the standard controller. BI batteries are only for BI controllers.

STWRENCH CABLE BOX

Wired to connect the STwrench to the Power Focus using a standard Tensor SL cable. The STwrench cable box supplies power to the wrench and handles the communication between the wrench and the Power Focus.

STWRENCH BATTERY CHARGER

To recharge the battery, it can be mounted in a horizontal or vertical position, It takes 4 hours to complete recharge the STwrench battery.

QATNODE

Three different models of QATnode enable the solution to be customized to specific needs. The QATnode can be connected to the STwrench in WiFi via access point, in real time connection, or via IrDa with wrench locked on the QATnode, in non real time connection when wireless is not possible.

QATNODE P

Used to print out a ticket result on a 40 column serial printer. The layout of the ticket is fully configurable via TT BLM.

QATNODE I/O

In addition to QATnode P functionality it has 6 digital inputs and 5 digital outputs. All of them are fully configurable and it is possible to enable/disable the wrench, select a PSet or JOB and send out an OK or NOK.

QATNODE T

In addition to STwrench PokaYoke functionality it makes it possible to send data to the ToolsNet server.

| | Ordering No. |
|--------------------------------------|--------------|
| IRC-B Module | 8059 0920 10 |
| IRC-W Module | 8059 0920 15 |
| Bar Code | 8059 0920 12 |
| Battery | 8059 0930 86 |
| Battery BI | 8059 0930 85 |
| Battery HD | 8059 0930 83 |
| Battery charger | 8059 0930 88 |
| Battery charger adapter BI | 8059 0930 89 |
| Cable box | 8059 0920 24 |
| QATnode P | 8059 0920 25 |
| QATnode I/O | 8059 0920 26 |
| QATnode T | 8059 0920 27 |
| Tool holder | 8059 0930 70 |
| Controller rubber protection | 8059 0930 72 |
| Standard Battery rubber protection | 8059 0930 73 |
| 30/80 Nm smarthead rubber protection | 8059 0930 74 |
| 150 Nm smarthead rubber protection | 8059 0930 75 |
| 250 Nm smarthead rubber protection | 8059 0930 76 |
| 400 Nm smarthead rubber protection | 8059 0930 79 |



IRC-module



Battery



Bar Code



Tool holder



Battery charger



QATnode

PF, IRC FOCUS & QIF ACCESSORIES

For fieldbus connectivity and additional I/O port, or for backup station, the STwrench can be connected in wireless with PF or IRC Focus. It allow also the possibility to connect all QIF accessories such as stack light etc ...

TOOL HOLDER

The tool holder is a cradle for the STwrench that can be mounted either

on a table or on a wall, providing a safe housing for the wrench.

RUBBER PROTECTION

Rubber protections for the STwrench provide both a protection for surfaces that come in contact with the wrench and a better grip for the user. Choose a rubber protection for each of the sections of the STwrench.

END FITTING TOOLS FOR WRENCHES

The end fitting tools are the tool that can be attached in front of the wrench. There are two types of models, without and with TAG. TAG is a patented solution used by the STwrench to check the process. In the TAG the STwrench can write a number that can be used for socket recognition and the Torque/Angle calibration factor of the extension for automatic calibration. Both types are also compatible with LABwrench.

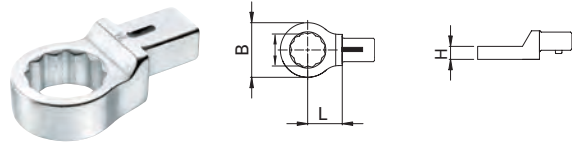

| Type | Hex mm | B mm | H mm | L mm | g | Ordering No. |
|-----------------|--------|------|------|------|-----|--------------|
| Ring end 9 x 12 | 7 | 13 | 8 | 17.5 | 37 | 4620 0014 00 |
| | 8 | 14.2 | 8 | 17.5 | 40 | 4620 0015 00 |
| | 10 | 17.2 | 9 | 17.5 | 44 | 4620 0016 00 |
| | 11 | 18.5 | 9 | 17.5 | 41 | 4620 0017 00 |
| | 12 | 20 | 12 | 17.5 | 49 | 4620 0018 00 |
| | 13 | 21.5 | 12 | 17.5 | 56 | 4620 0019 00 |
| | 14 | 23 | 12 | 17.5 | 52 | 4620 0020 00 |
| | 15 | 24.2 | 12 | 17.5 | 52 | 4620 0021 00 |
| | 16 | 25.7 | 13 | 17.5 | 54 | 4620 0022 00 |
| | 17 | 27.2 | 13 | 17.5 | 59 | 4620 0023 00 |
| | 18 | 28.5 | 13 | 17.5 | 56 | 4620 0024 00 |
| | 21 | 33 | 15 | 17.5 | 71 | 4620 0026 00 |
| | 22 | 34.5 | 15 | 17.5 | 74 | 4620 0027 00 |
| 14 x 18 | 13 | 21.5 | 11 | 25 | 127 | 4620 0063 00 |
| | 14 | 23 | 11 | 25 | 123 | 4620 0064 00 |
| | 15 | 24.2 | 11 | 25 | 128 | 4620 0065 00 |
| | 16 | 25.7 | 12 | 25 | 133 | 4620 0066 00 |
| | 17 | 27.2 | 12 | 25 | 135 | 4620 0067 00 |
| | 18 | 28.5 | 12 | 25 | 134 | 4620 0068 00 |
| | 19 | 30.5 | 12 | 25 | 138 | 4620 0069 00 |
| | 21 | 33 | 15 | 25 | 144 | 4620 0070 00 |
| | 22 | 34.5 | 15 | 25 | 145 | 4620 0071 00 |
| | 24 | 37.5 | 15 | 25 | 153 | 4620 0072 00 |
| | 27 | 41.5 | 17 | 25 | 162 | 4620 0073 00 |
| | 30 | 45 | 19 | 25 | 182 | 4620 0074 00 |
| | 32 | 47.5 | 19 | 25 | 181 | 4620 0075 00 |
| | 34 | 50.5 | 19 | 28 | 210 | 4620 0076 00 |
| | 36 | 53 | 19 | 28 | 203 | 4620 0077 00 |
| | 41 | 59 | 20 | 30 | 240 | 4620 0078 00 |

STANDARD END FITTING TOOLS WITH TAG

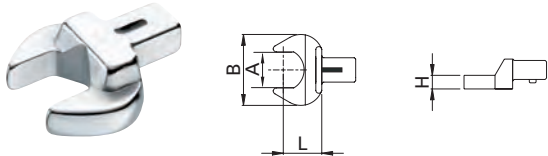

| Type | A mm | B mm | H mm | L mm | g | Ordering No. |
|-----------------|------|------|------|------|-----|--------------|
| Open end 9 x 12 | 7 | 22 | 5 | 17.5 | 40 | 4620 0001 00 |
| | 8 | 22 | 5 | 17.5 | 39 | 4620 0002 00 |
| | 9 | 26 | 5.5 | 17.5 | 38 | 4620 0003 00 |
| | 10 | 26 | 5.5 | 17.5 | 42 | 4620 0004 00 |
| | 11 | 26 | 5.5 | 17.5 | 41 | 4620 0005 00 |
| | 12 | 30 | 7 | 17.5 | 43 | 4620 0006 00 |
| | 13 | 30 | 7 | 17.5 | 48 | 4620 0007 00 |
| | 14 | 35 | 8 | 17.5 | 52 | 4620 0008 00 |
| | 15 | 35 | 8 | 17.5 | 51 | 4620 0009 00 |
| | 16 | 38 | 8.5 | 17.5 | 58 | 4620 0010 00 |
| | 17 | 38 | 8.5 | 17.5 | 60 | 4620 0011 00 |
| | 18 | 42 | 9 | 20 | 71 | 4620 0012 00 |
| | 19 | 42 | 9 | 20 | 74 | 4620 0013 00 |
| 14 x 18 | 13 | 30 | 7 | 25 | 128 | 4620 0049 00 |
| | 14 | 35 | 8 | 25 | 129 | 4620 0050 00 |
| | 15 | 35 | 8 | 25 | 132 | 4620 0051 00 |
| | 16 | 38 | 9 | 25 | 140 | 4620 0052 00 |
| | 17 | 38 | 9 | 25 | 136 | 4620 0053 00 |
| | 18 | 42 | 10 | 25 | 147 | 4620 0054 00 |
| | 19 | 42 | 10 | 25 | 147 | 4620 0055 00 |
| | 21 | 50 | 11 | 25 | 171 | 4620 0056 00 |
| | 22 | 50 | 11 | 25 | 165 | 4620 0057 00 |
| | 24 | 53 | 12 | 25 | 167 | 4620 0058 00 |
| | 27 | 60 | 13 | 30 | 219 | 4620 0059 00 |
| | 30 | 66 | 14 | 30 | 245 | 4620 0060 00 |
| | 32 | 66 | 14 | 32.5 | 246 | 4620 0061 00 |
| | 34 | 66 | 14 | 32.5 | 239 | 4620 0062 00 |

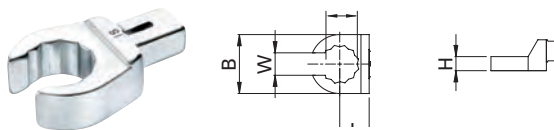

| Type | Hex mm | B mm | H mm | W mm | L mm | g | Ordering No. |
|-------------------|--------|------|------|------|------|--------------|--------------|
| Flared end 9 x 12 | 10 | 22 | 12 | 7.1 | 17.5 | 57 | 4620 0028 00 |
| | 11 | 22.5 | 12 | 8.6 | 17.5 | 55 | 4620 0029 00 |
| | 12 | 23.5 | 12 | 9 | 17.5 | 59 | 4620 0030 00 |
| | 13 | 25.2 | 12 | 10 | 17.5 | 55 | 4620 0031 00 |
| | 14 | 27 | 13 | 11 | 17.5 | 60 | 4620 0032 00 |
| | 16 | 30 | 13 | 13 | 17.5 | 65 | 4620 0033 00 |
| | 17 | 31.5 | 13 | 14 | 17.5 | 65 | 4620 0034 00 |
| | 18 | 33 | 15 | 14.8 | 17.5 | 74 | 4620 0035 00 |
| | 19 | 34.5 | 15 | 15.8 | 19 | 80 | 4620 0036 00 |
| 21 | 37.5 | 15 | 16.2 | 19 | 88 | 4620 0037 00 | |
| 22 | 39 | 15 | 17 | 19 | 92 | 4620 0038 00 | |
| 24 | 42 | 15 | 18 | 19 | 75 | 4620 0039 00 | |

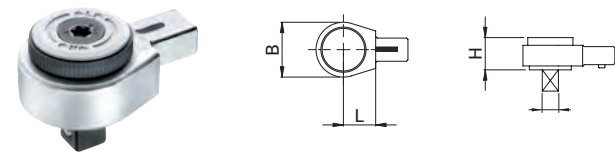

| Type | Hex in | B mm | H mm | L mm | g | Ordering No. |
|---------------------------|--------|------|------|------|------|---------------------------|
| Reversible ratchet 9 x 12 | 1/4 | 22 | 14.5 | 17.5 | 62 | 4620 0043 00 |
| | 3/8 | 33 | 24 | 17.5 | 136 | 4620 0044 00 |
| | 1/2 | 33 | 28.3 | 17.5 | 147 | 4620 0045 00 |
| 14 x 18 | 1/2 | 43 | 26.2 | 25 | 302 | 4620 0081 00 ^a |
| | 3/4 | 50 | 30.7 | 25 | 467 | 4620 0082 00 |
| 21 x 26 | 3/4 | 69 | 30 | 62.5 | 1350 | 4620 0086 00 |

The TAG placed on the ratchet defines the Pset.

^a **NOTE:** The maximum torque which can be applied with 4620 0081 00 is 300 Nm.

NOTE: Since several sockets could be used, it is recommended to hold the socket in such a way that it is not possible to remove it (e.g. using a pin).

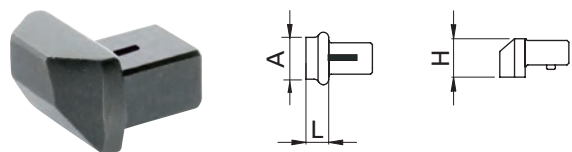

| Type | A mm | H mm | L mm | g mm | Ordering No. |
|---|---------|------|------|------|--------------|
| Blank end 9 x 12 for making up specials | 8 x 14 | 14.5 | 8 | 30 | 4620 0048 00 |
| Blank end 14 x 18 | 11 x 25 | 21.5 | 21 | 98 | 4620 0084 00 |
| | 13 x 30 | 30 | 13 | 220 | 4620 0085 00 |

Wrenches

End Fittings STwrench

STANDARD END FITTING TOOLS WITHOUT TAG

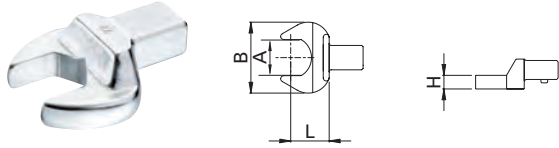

| Type | A mm | B mm | H mm | L mm | g | Ordering No. | |
|-----------------|---------|------|------|------|-----|--------------|--------------|
| Open end 9 x 12 | 7 | 22 | 5 | 17.5 | 40 | 8059 0975 00 | |
| | 8 | 22 | 5 | 17.5 | 39 | 8059 0975 01 | |
| | 9 | 26 | 5.5 | 17.5 | 38 | 8059 0975 02 | |
| | 10 | 26 | 5.5 | 17.5 | 42 | 8059 0975 03 | |
| | 11 | 26 | 5.5 | 17.5 | 41 | 8059 0975 04 | |
| | 12 | 30 | 7 | 17.5 | 43 | 8059 0975 05 | |
| | 13 | 30 | 7 | 17.5 | 48 | 8059 0975 06 | |
| | 14 | 35 | 8 | 17.5 | 52 | 8059 0975 07 | |
| | 15 | 35 | 8 | 17.5 | 51 | 8059 0975 08 | |
| | 16 | 38 | 8.5 | 17.5 | 58 | 8059 0975 09 | |
| | 17 | 38 | 8.5 | 17.5 | 60 | 8059 0975 10 | |
| | 18 | 42 | 9 | 20 | 71 | 8059 0975 11 | |
| | 14 x 18 | 19 | 42 | 9 | 20 | 74 | 8059 0975 12 |
| | | 13 | 30 | 7 | 25 | 128 | 8059 0976 00 |
| | | 14 | 35 | 8 | 25 | 129 | 8059 0976 01 |
| | | 15 | 35 | 8 | 25 | 132 | 8059 0976 02 |
| | | 16 | 38 | 9 | 25 | 140 | 8059 0976 03 |
| | | 17 | 38 | 9 | 25 | 136 | 8059 0976 04 |
| 18 | | 42 | 10 | 25 | 147 | 8059 0976 05 | |
| 19 | | 42 | 10 | 25 | 147 | 8059 0976 06 | |
| 21 | | 50 | 11 | 25 | 171 | 8059 0976 07 | |
| 22 | | 50 | 11 | 25 | 165 | 8059 0976 08 | |
| 24 | | 53 | 12 | 25 | 167 | 8059 0976 09 | |
| 27 | | 60 | 13 | 30 | 219 | 8059 0976 10 | |
| 30 | | 66 | 14 | 30 | 245 | 8059 0976 11 | |
| 32 | | 66 | 14 | 32.5 | 246 | 8059 0976 12 | |
| 34 | | 66 | 14 | 32.5 | 239 | 8059 0976 13 | |

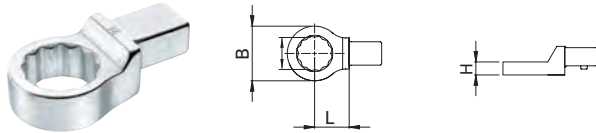

| Type | Hex mm | B mm | H mm | L mm | g | Ordering No. | |
|-----------------|---------|------|------|------|--------------|--------------|--------------|
| Ring end 9 x 12 | 7 | 13 | 8 | 17.5 | 37 | 8059 0975 13 | |
| | 8 | 14.2 | 8 | 17.5 | 40 | 8059 0975 14 | |
| | 10 | 17.2 | 9 | 17.5 | 44 | 8059 0975 15 | |
| | 11 | 18.5 | 9 | 17.5 | 41 | 8059 0975 16 | |
| | 12 | 20 | 12 | 17.5 | 49 | 8059 0975 17 | |
| | 13 | 21.5 | 12 | 17.5 | 56 | 8059 0975 18 | |
| | 14 | 23 | 12 | 17.5 | 52 | 8059 0975 19 | |
| | 15 | 24.2 | 12 | 17.5 | 52 | 8059 0975 20 | |
| | 16 | 25.7 | 13 | 17.5 | 54 | 8059 0975 21 | |
| | 17 | 27.2 | 13 | 17.5 | 59 | 8059 0975 22 | |
| | 18 | 28.5 | 13 | 17.5 | 56 | 8059 0975 23 | |
| | 19 | 30.3 | 13 | 17.5 | 65 | 8059 0975 24 | |
| | 21 | 33 | 15 | 17.5 | 71 | 8059 0975 25 | |
| | 22 | 34.5 | 15 | 17.5 | 74 | 8059 0975 26 | |
| | 14 x 18 | 13 | 21.5 | 11 | 25 | 127 | 8059 0976 14 |
| | | 14 | 23 | 11 | 25 | 123 | 8059 0976 15 |
| | | 15 | 24.2 | 11 | 25 | 128 | 8059 0976 16 |
| | | 16 | 25.7 | 12 | 25 | 133 | 8059 0976 17 |
| | | 17 | 27.2 | 12 | 25 | 135 | 8059 0976 18 |
| | | 18 | 28.5 | 12 | 25 | 134 | 8059 0976 19 |
| | | 19 | 30.5 | 12 | 25 | 138 | 8059 0976 20 |
| 21 | | 33 | 15 | 25 | 144 | 8059 0976 21 | |
| 22 | | 34.5 | 15 | 25 | 145 | 8059 0976 22 | |
| 24 | | 37.5 | 15 | 25 | 153 | 8059 0976 23 | |
| 27 | | 41.5 | 17 | 25 | 162 | 8059 0976 24 | |
| 30 | | 45 | 19 | 25 | 182 | 8059 0976 25 | |
| 32 | | 47.5 | 19 | 25 | 181 | 8059 0976 26 | |
| 34 | | 50.5 | 19 | 28 | 210 | 8059 0976 27 | |
| 36 | | 53 | 19 | 28 | 203 | 8059 0976 28 | |
| 41 | 59 | 20 | 30 | 240 | 8059 0976 29 | | |

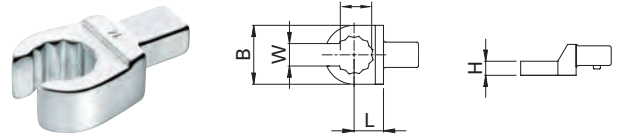

| Type | Hex mm | B mm | H mm | W mm | L mm | g | Ordering No. |
|-------------------|--------|------|------|------|------|----|--------------|
| Flared end 9 x 12 | 10 | 22 | 12 | 7.1 | 17.5 | 57 | 8059 0975 27 |
| | 11 | 22.5 | 12 | 8.6 | 17.5 | 55 | 8059 0975 28 |
| | 12 | 23.5 | 12 | 9 | 17.5 | 59 | 8059 0975 29 |
| | 13 | 25.2 | 12 | 10 | 17.5 | 55 | 8059 0975 30 |
| | 14 | 27 | 13 | 11 | 17.5 | 60 | 8059 0975 31 |
| | 16 | 30 | 13 | 13 | 17.5 | 65 | 8059 0975 32 |
| | 17 | 31.5 | 13 | 14 | 17.5 | 65 | 8059 0975 33 |
| | 18 | 33 | 15 | 14.8 | 17.5 | 74 | 8059 0975 34 |
| | 19 | 34.5 | 15 | 15.8 | 19 | 80 | 8059 0975 35 |
| | 21 | 37.5 | 15 | 16.2 | 19 | 88 | 8059 0975 36 |
| | 22 | 39 | 15 | 17 | 19 | 92 | 8059 0975 37 |
| | 24 | 42 | 15 | 18 | 19 | 75 | 8059 0975 38 |

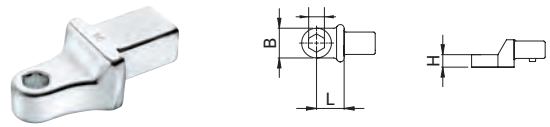

| Type | Hex in | B mm | H mm | L mm | g | Ordering No. |
|--------------------|---------|------|------|------|----|--------------|
| Bits holder 9 x 12 | 1/4 | 14 | 10 | 17.5 | 50 | 8059 0975 45 |
| | 5/16 | 16 | 12.5 | 17.5 | 47 | 8059 0975 46 |
| | 14 x 18 | 5/16 | 16 | 12.5 | 25 | 112 |

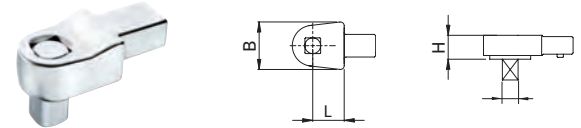

| Type | Hex in | B mm | H mm | L mm | g | Ordering No. | |
|---------------------|---------|------|------|------|----|--------------|--------------|
| Fixed square 9 x 12 | 1/4 | 22 | 14 | 17.5 | 71 | 8059 0975 39 | |
| | 3/8 | 22 | 14 | 17.5 | 76 | 8059 0975 40 | |
| | 1/2 | 22 | 14 | 17.5 | 82 | 8059 0975 41 | |
| | 14 x 18 | 1/2 | 30 | 18 | 25 | 203 | 8059 0976 30 |
| | | 3/4 | 40 | 25 | 25 | 396 | 8059 0976 31 |

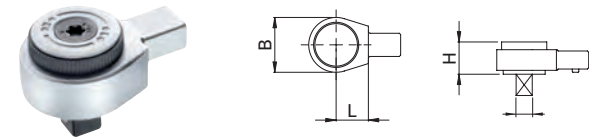

| Type | Hex in | B mm | H mm | L mm | g | Ordering No. | |
|---------------------------|---------|------|------|------|------|--------------|---------------------------|
| Reversible ratchet 9 x 12 | 1/4 | 22 | 14.5 | 17.5 | 62 | 8059 0975 42 | |
| | 3/8 | 33 | 24 | 17.5 | 136 | 8059 0975 43 | |
| | 1/2 | 33 | 28.3 | 17.5 | 147 | 8059 0975 44 | |
| | 14 x 18 | 1/2 | 43 | 26.2 | 25 | 302 | 8059 0976 32 ^a |
| | | 3/4 | 50 | 30.7 | 25 | 467 | 8059 0976 33 |
| | 21 x 26 | 3/4 | 69 | 30 | 62.5 | 1350 | 8059 0976 38 |

^a NOTE: The maximum torque which can be applied with 4620 0081 00 is 300 Nm.

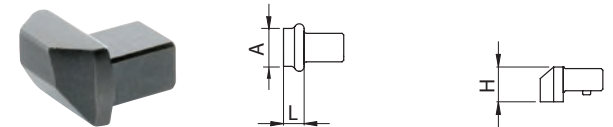

| Type | A mm | H mm | L mm | g mm | Ordering No. |
|-------------------|---------|------|------|------|--------------|
| Blank end 9 x 12 | 8 x 14 | 14.5 | 8 | 30 | 8059 0975 47 |
| Blank end 14 x 18 | 11 x 25 | 21.5 | 21 | 98 | 8059 0976 35 |
| 21 x 26 | 13 x 30 | 30 | 13 | 220 | 8059 0976 36 |

JOINT SIMULATOR BENCH AD

The Joint Simulator Bench AD provides maximum tool evaluation flexibility. DC electric, clutch, impulse and battery tools as well as torque wrenches can be evaluated.

The hydraulic brakes simulate the behaviour of a real joint, reproducing the stiffness from hard to soft.

This allows the tool to be tested in accordance with VDI/VDE 2647. Machine capability (Cm, Cmk) can be tested quickly and easily under real shop floor conditions without the need to run tests on the product on the line that would interfere with production.

- Large LCD touch screen, intuitive and easy to use.
- Efficient hydraulic pump fills the pressure accumulator in just 15 seconds reducing battery drain.
- Connector panel manages all operator connections such as external in-line torque transducers, printers, Ethernet, USB and serial.



| Model | Hydraulic brakes, range | | SRTT-B transducers range | | ISO rig | Ordering No. |
|-----------------------|-------------------------|----------|--------------------------|---------|---------|--------------|
| | Nm | lb ft | Nm | lb ft | | |
| Mobile benches | | | | | | |
| JSB AD 250 | 2-10 | 1.6-185 | 50-250 | 37-184 | – | 8059 0962 00 |
| | 10-50 | 7.4-36 | | | | |
| | 50-250 | 37-184 | | | | |
| JSB AD 250 ISO | 2-10 | 1.6-185 | 50-250 | 37-184 | yes | 8059 0962 30 |
| | 10-50 | 7.4-36 | | | | |
| | 50-250 | 37-184 | | | | |
| JSB AD 500 ISO | 2-10 | 1.6-185 | 50-250 | 37-184 | yes | 8059 0962 35 |
| | 10-50 | 7.4-36 | | | | |
| | 50-250 | 37-184 | 100-500 | 74-368 | | |
| | 100-500 | 74-368 | | | | |
| JSB AD 1000 ISO | 2-10 | 1.6-185 | 50-250 | 37-184 | yes | 8059 0962 40 |
| | 50-250 | 37-184 | | | | |
| | 100-500 | 74-368 | 200-1000 | 148-737 | | |
| | 200-1000 | 148-737 | | | | |
| JSB AD 2000 ISO | 2-10 | 1.6-185 | 50-250 | 37-184 | yes | 8059 0962 50 |
| | 10-50 | 7.4-36 | | | | |
| | 50-250 | 37-184 | 200-1000 | 148-737 | | |
| | 400-2000 | 295-1475 | | | | |

Dimensions

JSB AD

| Model | L mm | W mm | H mm |
|-----------------|---------|---------|---------|
| JSB AD 250 | 1164 | 546 | 940 |
| JSB AD 250 ISO | 1346 | 707 | 940 |
| JSB AD 500 ISO | 1566 | 767 | 940 |
| JSB AD 1000 ISO | 1566 | 767 | 940 |
| JSB AD 2000 ISO | 1566 | 767 | 940 |

ATLAS COPCO STATIC TRANSDUCER BENCH

The Atlas Copco Static Transducer Bench is a mobile bench as it is equipped by a battery pack that makes possible to operate for up to 16 hours without to be connected to the power supply plug.

On the top plate of the bench there are several static torque transducers. The static torque transducers are the new SRTT-B.

The New SRTT-B is equipped by the new patented system to hold the mechanical Test Joint. The mechanical Test Joint is to test direct driven tool or shut off pulse tools.

The SRTT-B has a special bearing on the shaft to absorb and eliminate the axial force during the test, this is to have the best possible accuracy during the test.

By using a special included adapter on the SRTT-B it is possible to test the click wrenches, wrenches and non shut off pulse tools.



| Model | SRTT-B range | | Spindle fixture ISO rig | Dimensions holder | Ordering No. |
|-------------|--------------|--------|-------------------------|-------------------|--------------|
| | Nm | lb ft | | | |
| STB AD 500 | 10-500 | 8-365 | yes | no | 8059 0961 00 |
| STB AD 1000 | 10-1000 | 8-735 | yes | no | 8059 0961 50 |
| STB AD 2000 | 10-2000 | 8-1470 | yes | no | 8059 0961 75 |

Dimensions

STB AD

| Model | L mm | W mm | H mm |
|-------------|------|------|------|
| STB AD 500 | 1346 | 707 | 940 |
| STB AD 1000 | 1346 | 707 | 940 |
| STB AD 2000 | 1346 | 767 | 940 |

JOINT SIMULATOR BENCH 3840

JSB 3840 is an ergonomic solution, which provides in a single mobile unit, all necessary equipment needed for measuring, such as all transducers, adapters, cables, reaction bar, battery and an industrial PC. The alternative is to carry and connect/disconnect constantly all these equipment together, so the JSB 3840 represents a cost effective & ergonomic solution.

JSB 3840 includes:

- A 12" touch screen color display, and heavy duty industrial PC.
- Port: RS232 for printing certificates, USB for RBU automatic back-up function and Ethernet for server option.
- Slim frame of 40 cm wide, to easily move across narrow production lines.
- 16 hours of battery life & embedded battery charger, to be used in 2 shift.
- 1 set of accessories adapter, located in a lock drawer, to allow the tool connection
- 1 reaction bar & adapted accessories, to ensure a safety measurement for the operator.
- Torque Supervisor software, with up to 2000 tools Database, Easy SPC analysis, Cm/Cmk graphs and certificates plus excel export.



| Model | Hydraulic brakes, range | | SRTT-B transducers range | | Ordering No. |
|----------|-------------------------|-------------|--------------------------|-------------|--------------|
| | Nm | lb ft | Nm | lb ft | |
| JSB 3840 | 5-85 | 3.69-62.69 | 25-250 | 18.44-184.4 | 8059 0967 10 |
| JSB 3840 | 25-250 | 18.44-184.4 | 50-500 | 36.88-368.8 | 8059 0967 20 |

Dimensions

JSB 3840

| Model | L mm | W mm | H mm |
|----------|---------|---------|---------|
| JSB 3840 | 1034 | 416 | 935 |
| JSB 3840 | 1034 | 416 | 935 |

Quality Assurance in Tightening Management Software

BLM TORQUE SUPERVISOR

The software BLM Torque Supervisor is the ideal program for handling tools, tightening and joint analysis. It automatically keeps track of calibration due date schedules for power tools and torque wrenches, as well as supervising the complete tool stock within the factory. It manages and collects data from residual torque checks done on the assembly line as well as tool checks done at the tool crib, and supervises statistics for each tool and application. The software can be installed either on a single pc station or on multi factory stations in the factory network.

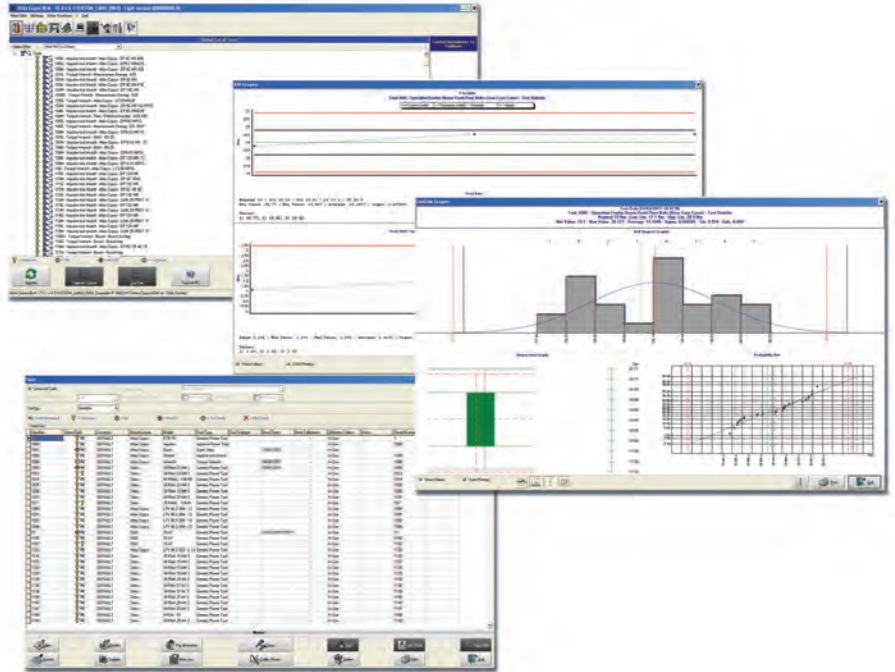

TORQUE SUPERVISOR

| Version | Ordering No. |
|------------------------------------|--------------|
| Full version 1 user | 8059 0981 00 |
| Full version 5 users | 8059 0981 09 |
| Full version 10 users | 8059 0981 30 |
| Tool Crib version | 8059 0981 25 |
| Tool Crib version 5 users | 8060 0981 26 |
| Tool Crib version 10 users | 8061 0981 27 |
| Residual version | 8062 0981 32 |
| Residual version 5 users | 8063 0981 33 |
| Residual version 10 users | 8064 0981 34 |
| Advanced version | 8065 0981 36 |
| Advanced version 5 users | 8066 0981 37 |
| Advanced version 10 users | 8059 0981 38 |
| Light version | 8059 0981 01 |
| Client version, installed on bench | 8059 0981 03 |
| Upgrade from Light to Full version | 8059 0981 06 |

VERSION OVERVIEW

| | Full | Light | Tool Crib | Residual | Advanced |
|-------------------|------|-------|-----------|----------|----------|
| JSB bench | x | x | | | |
| Tool check route | x | | x | | x |
| Joint check route | x | | | x | x |

GRINDERS

Contents

| | |
|---|-----|
| Introduction..... | 223 |
| Guide | 224 |
| Product safety..... | 225 |
| Turbine grinders and sanders..... | 226 |
| Die grinders | 229 |
| Straight grinders | 231 |
| Angle grinders | 233 |
| Angle sanders..... | 235 |
| Orbital and random orbital sanders..... | 237 |
| Dust extraction..... | 239 |
| Routers | 242 |
| Circular cutters | 243 |



Maximum material removal with minimum effort

Atlas Copco Grinders are designed to be powerful, yet small in size and weight. With Atlas Copco Grinders, you can rely on maximum material removal with minimum effort. Our range of grinders covers virtually all applications.

DIE GRINDING

Small precision deburring – die grinding is performed with either tungsten carbide, high speed steel burrs or mounted points.

The choice of burr depends on the size of your job. A larger volume of removed material will require a bigger size of the burr's head.

Select the tool rpm depending on the diameter of the burr head, the material to be ground and the material in the rotary burr. Use tungsten carbide burrs for hard and tough materials. High speed steel burrs are recommended for natural steel and medium hardened materials. Example, see table below:

| Burr head Ø | | Hardened steel | Natural steel | Soft material |
|-------------|-------|------------------|-------------------------------|------------------------------|
| | | Though materials | Softer materials Cast iron | Wood, brass Plastics, Al. |
| Up to 1/4" | - TC | 38000 | 38000 | 38000 |
| | - HSS | - | 20000 | 20000 |
| Up to 1/2" | - TC | 30000 | 30000 | 30000 |
| | - HSS | - | - | 20000 |

TC – Tungsten carbide tipped rotary burr. HSS – High speed steel burrs.

For mounted points, follow the recommendations that relate to the particular mounted point.

ROUGH GRINDING

Pure material removal is determined by the power generated at the grinding process. The applied feed force and the rotation of the wheel generates a cutting force which, multiplied by the peripheral speed of the wheel, represents the power of removed material. (Power=Peripheral speed x Cutting force).

A powerful grinder will provide enough power with maintained rotational speed, when applying feed-force. A suitable combination of operative rotational speed, feed-force applied by the operator and power of the grinder, will give you the best combination for the material removal required.

As rough grinding is performed with bonded abrasives, a limitation of rotational speed is necessary in order to prevent wheel fractures due to centrifugal force.

The peripheral speed is limited to 14200 S.F.P.M (surface feet per minute) for fiber reinforced depressed center, straight and cutting off wheels. Resin bonded cup and straight wheels are limited to a peripheral speed of 9000 S.F.P.M.

SANDING AND POLISHING

Unlike die and rough grinding, sanding and polishing applies to the requirements of a surface. A fine surface will require a fine grit paper, fine Scotch-Brite, Bear Tex or a soft polishing bonnet. Rougher surface grinding will require a higher material removal rate thus requiring a coarser grit paper.

Similar to rough grinding, a rough surface, ground with coarse grit, will benefit from a high rotational speed. The limitations, however, are the maximum allowed speed of the backing pad and the fiber disc.

Normal sanding speeds for fiber discs of diameter 5", 7" and 9" are 4000 to 6000 rpm.

Polishing with different pastes and compounds require low speed in combination with high torque. Suitable speeds are 1800 to 2200 rpm.

Sanding with wet coated abrasives is best performed at low speeds, because water is thrown out into the periphery and partly because of the fine grit.

Scotch-Brite, Bear Tex and flap wheels perform best at 50% of their maximum allowed rotational speeds.

THE SPEED GOVERNOR

The amount of material removed in the grinding process depends on the power of the tool and the operative rotational speed. The diagram below shows the correlation between torque, power and rotational speed of a non governed pneumatic grinder.

In order to remove material, the operator has to apply a feed-force on the work-piece.

Consequently the rotational speed decreases and having passed approximately 50% of the free speed, the operative power output starts to decrease. Theoretically, the most material would be removed at approximately 50% of the free speed on a non governed grinder, (diagram 1).

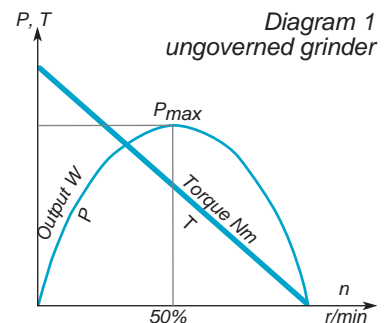

The Atlas Copco grinders are built small and smooth, partly due to their speed governor. The air is governed to the air flow necessary to maintain the rotational speed regardless of load, (to the extent of the power of the grinder).

The correlation between power, torque and rotational speed of a governed grinder is shown in diagram 2.

A theoretical optimum of material removal is reached at approximately 80% of the free speed. The grinder generates max power, removing more material with applied feed force. The rotational speed decreases are negligible.

Air is used economically, as the flow through the motor is adjusted after applied load. Air consumption at free speed is minimized. The governor opens and lets in more air during load thus keeping the optimal rpm.

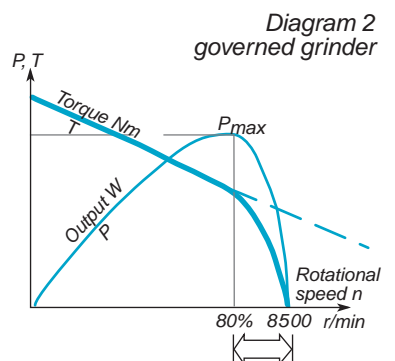

Guides

DIE GRINDING AND DEBURRING

SEE PAGE 229

1 Carbide burrs



2 Mounted points



ROUGH GRINDING AND CUTTING OFF

SEE PAGE 227 AND 233

3 Depressed center wheels



4 Cut off wheels



5 Cup wheels



6 Flap wheels



7 Straight wheels

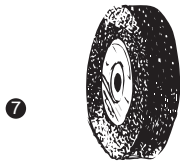

8 Cone wheels



SANDING AND POLISHING

SEE PAGE 235 AND 237

9 Fibre discs

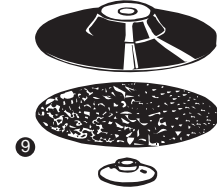

10 Wire brushes



11 Coated abrasives

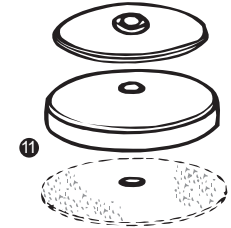

12 Polishing bonnets

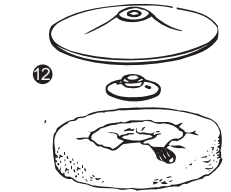

13 Radial flap wheels

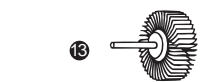

14 Scotch-Brite



DIAMETER – PERIPHERAL SPEED – R/MIN

The table below will help you to translate the peripheral speed of the grinding wheel to the correct rotational speed of the grinder when using a grinding wheel with a specific diameter.

| Wheel diameter inches | Surface feet per minute | | | | | | | | | | | | | | | | |
|-----------------------|-------------------------|--------|--------|--------|--------|--------|--------|--------|--------|--------|--------|--------|--------|--------|--------|--------|--|
| | 4,000 | 4,500 | 5,000 | 5,500 | 6,000 | 6,500 | 7,000 | 7,500 | 8,000 | 8,500 | 9,000 | 9,500 | 10,000 | 12,000 | 12,000 | 14,200 | |
| | Revolutions per minute | | | | | | | | | | | | | | | | |
| 1 | 15,279 | 17,189 | 19,099 | 21,008 | 22,918 | 24,828 | 26,737 | 28,647 | 30,558 | 32,467 | 34,377 | 36,287 | 38,197 | 45,837 | 47,746 | 54,240 | |
| 1 1/2 | 10,186 | 11,459 | 12,732 | 14,006 | 15,279 | 16,552 | 17,825 | 19,099 | 20,372 | 21,645 | 22,918 | 24,192 | 25,465 | 30,558 | 31,831 | 36,160 | |
| 2 | 7,639 | 8,594 | 9,549 | 10,504 | 11,459 | 12,414 | 13,369 | 14,324 | 15,279 | 16,234 | 17,189 | 18,144 | 19,099 | 22,918 | 23,873 | 27,120 | |
| 2 1/2 | 6,112 | 6,875 | 7,639 | 8,403 | 9,167 | 9,931 | 10,695 | 11,459 | 12,223 | 12,987 | 13,751 | 14,515 | 15,279 | 18,335 | 19,099 | 21,696 | |
| 3 | 5,093 | 5,730 | 6,366 | 7,003 | 7,639 | 8,276 | 8,913 | 9,549 | 10,186 | 10,823 | 11,459 | 12,096 | 12,732 | 15,279 | 15,915 | 18,080 | |
| 3 1/2 | 4,365 | 4,911 | 5,457 | 6,002 | 6,548 | 7,094 | 7,639 | 8,185 | 8,731 | 9,276 | 9,822 | 10,368 | 10,913 | 13,096 | 13,642 | 15,497 | |
| 4 | 3,820 | 4,297 | 4,775 | 5,252 | 5,730 | 6,207 | 6,685 | 7,162 | 7,640 | 8,117 | 8,594 | 9,072 | 9,549 | 11,459 | 11,937 | 13,560 | |
| 5 | 3,056 | 3,438 | 3,820 | 4,202 | 4,584 | 4,966 | 5,348 | 5,730 | 6,112 | 6,494 | 6,875 | 7,257 | 7,639 | 9,167 | 9,549 | 10,848 | |
| 6 | 2,546 | 2,865 | 3,183 | 3,501 | 3,820 | 4,138 | 4,456 | 4,775 | 5,093 | 5,411 | 5,730 | 6,048 | 6,366 | 7,639 | 7,958 | 9,040 | |
| 7 | 2,183 | 2,456 | 2,728 | 3,001 | 3,274 | 3,547 | 3,820 | 4,093 | 4,365 | 4,638 | 4,911 | 5,184 | 5,457 | 6,548 | 6,821 | 7,749 | |
| 8 | 1,910 | 2,149 | 2,387 | 2,626 | 2,865 | 3,104 | 3,342 | 3,581 | 3,820 | 4,058 | 4,297 | 4,536 | 4,775 | 5,730 | 5,968 | 6,780 | |
| 9 | 1,699 | 1,910 | 2,122 | 2,334 | 2,546 | 2,759 | 2,971 | 3,183 | 3,395 | 3,608 | 3,820 | 4,032 | 4,244 | 5,093 | 5,305 | 6,027 | |

THIS IS YOUR RESPONSIBILITY

Always read and understand the safety information supplied with the tool and on www.atlascopco.com. All locally legislated safety rules regarding installation, operation and maintenance shall be respected at all times.

1. Check the free speed

- The measured speed at a pressure of 6.3 bars must not exceed the rated speed, which is marked on the grinder.
- Remove the grinding wheel and outer flange before checking the free speed.
- Carry out checks daily.
- Make sure the speed marking on the tool is legible.
- Return the machine for repair in the event of overspeeding.



2. Check the wheel guard

The wheel guard protects your health and safety.

- Always use the recommended wheel guard.
- Check that it is not damaged.
- Never use a grinder without the wheel guard.
- Position the wheel guard between yourself and the grinding wheel.



Check that the trigger is working correctly.

- The trigger must never be removed or fixed by tape for example.
- If the trigger is not working properly, make sure that it is replaced.

3. Maximum speed

Make sure that the stated maximum speed of the grinding wheel is greater than or equal to the speed specified on the grinder.

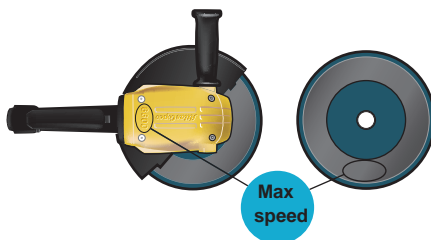

4. Check the grinding wheel

Make sure that the grinding wheel is not cracked or damaged in any way.

- The grinding wheel should have the correct hole dimensions and be fitted correctly on the spindle to avoid unbalanced vibrations.
- Damaged grinding wheels must be removed and replaced immediately.
- Do not use dropped or damaged wheels, as these can cause serious injuries.

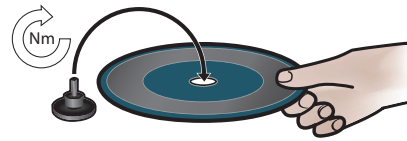

5. Check the flange and wheel

Make sure that flange and wheel combinations correspond to national regulations.

- Check that the flanges are undamaged and clean.
- Attach the wheel with the recommended torque.
- Always disconnect the air-supply when changing the wheel or adjusting the tool.
- Test-run your grinder in a protected area after assembling the wheel.
- Check that the grinder is working correctly.

6. Personal protection equipment

Make sure that operators wear:

- Eye protection, goggles or a visor.
- Ear protection.
- Gloves.
- Steel toe-capped shoes.
- Protective clothing, such as a leather apron.
- A helmet (for heavier applications).
- Avoid loosely hanging clothing, hair, jewellery (risk of getting caught).



7. Working area

Ensure that the area in which you are working is kept free from other people so that no one can get injured.

- People nearby must also wear hearing and eye protection.
- Check that there is good ventilation and dust extraction from the premises.
- There should be a stand or a place available, on which the machine can be safely placed.
- Work within a sealed-off area, if possible with protecting walls, since there is a risk that broken discs could fly off.

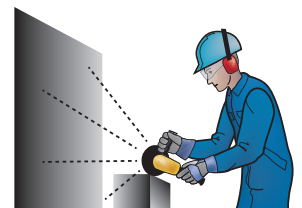

During work

Stop using the grinder if abnormally loud noises and vibrations occur during use. The grinder and its accessories must not be modified in any way.

After the work is finished

Make sure the machine is switched off and has come to a complete stop before it is put down. Put down the tool carefully, so that there is no risk of the tool starting by itself.



Maintenance

Make sure you follow the service instructions provided and the recommended service intervals. Do not dismantle safety-related parts such as the speed governor and overspeed shut off. These parts should be completely replaced when damaged.

TURBINE TECHNOLOGY BOOSTS PRODUCTIVITY

More efficient than a conventional vane grinder motor, the 2 stage turbine motor in the GTG25 provides an extremely high efficiency leading to great rate of material removal on the roughest surfaces. A speed governor ensures optimum process speed and process time is cut to a minimum. Since the job is done faster, the total energy consumption is significantly lower for each job.

REDUCES OPERATOR STRAIN

The GTG25 is ergonomically designed in every aspect. Its high power-to-weight ratio, 3.4 hp of power in a 5.07 lb tool, makes grinding much easier for the user. Combined with other GTG25 features, for example, an ergonomic angled throttle handle and an autobalancer to minimize vibrations, the overall result is less strain on the operator.



GTG25 F120-527



GTG25 F085-727

HIGHLY SERVICE FRIENDLY

With its all-metal design, the GTG25 turbine grinder is a robust, durable tool. Service intervals are long and servicing is easy thanks to modular internal components and Service Kits from Atlas Copco.

| Model | Max free speed r/min | For wheel dia in | Spindle thread | Max output hp | Weight lb | Height over spindle in | Air consumption at max output | | Rec. hose size | | Air inlet thread NPT | Ordering No. |
|-------------------------------------|----------------------|------------------|----------------|---------------|-----------|------------------------|-------------------------------|-----|----------------|-----|----------------------|--------------|
| | | | | | | | cfm | cfm | mm | in | | |
| For grinding and cutting off | | | | | | | | | | | | |
| GTG25 F120-527 | 12000 | 5 | 5/8-11 | 3.4 | 5.07 | 2.3 | 67.8 | 19 | 16 | 5/8 | 3/8 | 8423 2525 06 |
| GTG25 F085-727 | 8500 | 7 | 5/8-11 | 3.4 | 5.29 | 2.3 | 67.8 | 19 | 16 | 5/8 | 3/8 | 8423 2525 07 |
| For sanding | | | | | | | | | | | | |
| GTG25 S085-700 | 8500 | 7 | 5/8-11 | 3.4 | 4.2 | 2.3 | 67.8 | 19 | 16 | 5/8 | 3/8 | 8423 2525 08 |
| GTG25 S060-700 | 6000 | 7 | 5/8-11 | 3.4 | 4.2 | 2.3 | 67.8 | 19 | 16 | 5/8 | 3/8 | 8423 2525 22 |

TOOL ACCESSORIES

| Model | Ordering No. |
|-----------------------------|--------------|
| Whip-hose (incl.) | 4175 0738 91 |
| Exhaust hose | 4150 1532 95 |
| Spot suction kit for sander | 3780 4090 27 |

AIR LINE ACCESSORIES

| Model | Ordering No. |
|----------------------|--------------|
| MultiFlex | 8202 1350 28 |
| Claw coupling | 9000 0262 00 |
| HM Open XL hose reel | 8202 1183 50 |

SPOT SUCTION KIT FOR SANDING WITH FIBRE DISC

| Model | Ordering No. |
|---------------------------------|--------------|
| KIT 7" | 3780 4007 90 |
| 1 Chamber | 3780 3100 40 |
| 2 Suction cap 180 mm with brush | 3780 2675 00 |
| 3 Backing pad 180 mm | 3780 2710 60 |
| 6 Distance washer 9 mm | 3780 2721 50 |
| 5 Nut 5/8" | 3780 2726 70 |

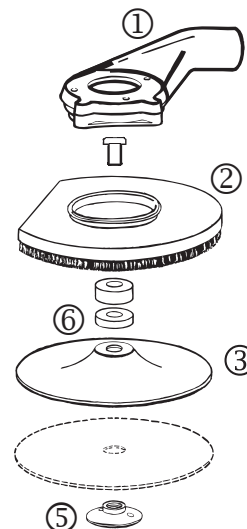

Productivity Kits

| Model | Max air flow | Hose 16.4 ft | Coupling | Lubrication | Ordering No. |
|--------------------------------|--------------|--------------|--------------|-------------|--------------|
| MIDI Optimizer F/RD EQ15US-T16 | 85 cfm | Turbo 16 | ErgoQIC 15US | Yes | 8202 0850 31 |

The GTG/GTR40 are the most powerful grinders in the turbine grinder range, with incredible power for their size and weight. The range includes angle and straight type grinders for virtually every common rough grinding application.

- For rough grinding and cutting off with depressed center wheels.
- For surface finishing with coated abrasives and wire brushes.
- For rough grinding with cup wheels.
- GTR40 – for rough grinding and applications such as internal and external cleaning of castings with straight grinding wheels.
- Dust extraction – Efficient accessory and standard model for extraction of air-borne dust in sanding applications with fiber discs.



MORE EFFECTIVE

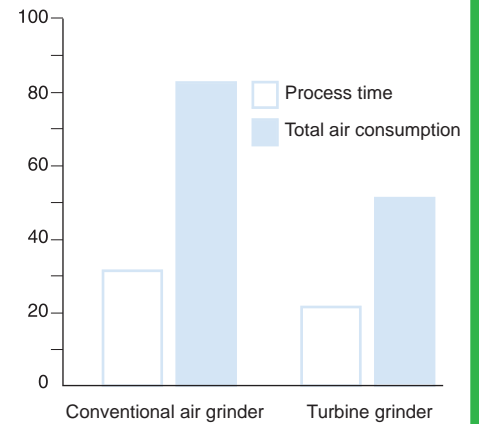

The turbine motor is more efficient than a conventional grinder motor. Therefore it takes less time to do the same job. Also the total air consumption will be a lot less for a specific job.

| Model | Max free speed r/min | Max wheel dia in | Max output hp | Weight lb | Height over spindle in | Air consumption at | | Hose size in | Air inlet thread NPT | Spindle thread in | Ordering No. |
|---|-------------------------|---------------------|------------------|--------------|---------------------------|--------------------|-------------------|-----------------|-------------------------|----------------------|--------------|
| | | | | | | max output cfm | free speed cfm | | | | |
| For depressed center wheels, type 27 | | | | | | | | | | | |
| GTG40 S060-927 | 6000 | 9 | 6.1 | 9.5 | 5.2 | 126 | 42 | 5/8 | 1/2 | UNC 5/8 | 8423 0715 05 |
| GTG40 S060-727 | 6000 | 7 | 6.1 | 9.5 | 5.2 | 126 | 42 | 5/8 | 1/2 | UNC 5/8 | 8423 0715 07 |
| GTG40 S077-727 | 7700 | 7 | 6.1 | 9.5 | 5.2 | 126 | 42 | 5/8 | 1/2 | UNC 5/8 | 8423 0715 09 |
| GTG40 S085-727 | 8500 | 7 | 6.1 | 9.5 | 4.8 | 126 | 42 | 5/8 | 1/2 | UNC 5/8 | 8423 0715 10 |
| For cup wheel, type 11 | | | | | | | | | | | |
| GTG40 S060-611 | 6000 | 6 | 6.1 | 10.1 | 5.2 | 126 | 42 | 5/8 | 1/2 | UNC 5/8 | 8423 0715 00 |
| GTG40 F072-611 | 7200 | 5 | 6.1 | 10.1 | 5.2 | 126 | 42 | 5/8 | 1/2 | UNC 5/8 | 8423 0715 20 |
| For sanding | | | | | | | | | | | |
| GTG40 S060-900 | 6000 | 9 | 6.1 | 7.9 | 5.2 | 126 | 42 | 5/8 | 1/2 | UNC 5/8 | 8423 0715 02 |
| GTG40 S060-700 | 6000 | 7 | 6.1 | 7.9 | 5.2 | 126 | 42 | 5/8 | 1/2 | UNC 5/8 | 8423 0715 03 |

| Model | Max. free speed r/min | Rec. wheel diam. DxTxH in | Spindle | | Max output hp | Weight incl. guard flanges lb | Length in | Air consumption at | | Air inlet thread NPT | Rec. air hose in | Ordering No. |
|----------------|--------------------------|---------------------------------|--------------|--------------|------------------|-------------------------------------|--------------|--------------------|-------------------|-------------------------|---------------------|--------------|
| | | | thread in | length in | | | | max output cfm | free speed cfm | | | |
| GTR40 S085-601 | 8500 | 6x1x1 | UNC 5/8 | 2.2 | 6.1 | 12.3 | 22.1 | 126 | 42 | 1/2 | 5/8 | 8423 0715 11 |
| GTR40 S072-501 | 7200 | 5x1x1 | UNC 5/8 | 2.2 | 6.1 | 12.3 | 22.1 | 126 | 42 | 1/2 | 5/8 | 8423 0715 13 |
| GTR40 S060-601 | 6000 | 6x1x1 | UNC 5/8 | 2.2 | 6.1 | 12.8 | 22.1 | 126 | 42 | 1/2 | 5/8 | 8423 0715 15 |
| GTR40 S060-801 | 6000 | 8x1x1 | UNC 5/8 | 2.2 | 6.1 | 12.8 | 22.1 | 126 | 42 | 1/2 | 5/8 | 8423 0715 17 |

Accessories Included

GTG40

Adjustable wheel guard
 Support handle
 Attachment flanges
 Whip hose 2 ft long, 5/8" dia complete with nipple
 Gear box oil, one tube
 Hex key for wheel change

GTR40

Wheel guard
 Attachment flanges
 Whip hose 2 ft long, 5/8" dia complete with nipple
 Gear box oil, one tube
 Key and spanner for wheel change

Optional Accessories

GTG40

| | Ordering No. |
|--|---------------------------|
| Heavy duty backing pad for sanding Ø 180 mm (7") | 4170 1192 90 |
| Ø 230 mm (9") | 4170 1193 90 |
| Hand shield | 4175 0165 90 |
| Adapter for positioning support handle 120/135° between handles | 4175 0164 90 ^b |
| Adapter kit fibre disc | 4175 0238 90 |
| Dust extraction kit for 180 mm fiber disc GTG40 S060-700 | 3780 4090 11 ^a |
| Hose kit including 1.8 m vacuum hose, Ø 38 mm and air hose Ø 13 mm | 3780 2724 41 |
| Attachment nut for cup wheel with plane hole | 4175 0178 90 |

^a Incl. flow chamber, suction cap and support pad.

^b Included as standard in GTG40 S060-611.

GTR40

| | Thickness x Hole dia in | See illustration | Ordering No. |
|-----------------------|-------------------------|------------------|--------------|
| Rear flange | 3/4-1 x 5/8 | 2a | 4150 0619 00 |
| | | 2a | 4150 0713 00 |
| | | 2b | 4150 1650 00 |
| | | 2c | 4150 0620 00 |
| Spacer for cone wheel | x 1 1/4 | 3 | 4150 0787 00 |

GTG40

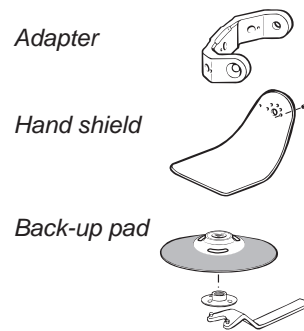

GTR40

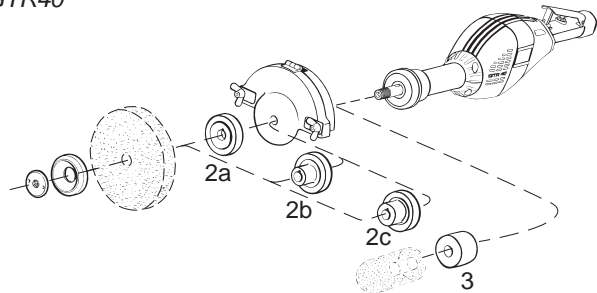

Productivity Kits

| Model | Max air flow | Hose 16.4 ft | Coupling | Lubrication | Ordering No. |
|----------------------|--------------|--------------|--------------|-------------|--------------|
| MAXI F/R EQ15US-T20 | 140 cfm | Turbo 16 | ErgoQIC 15US | No | 8202 0850 32 |
| MAXI F/RD EQ15US-T20 | 140 cfm | Turbo 16 | ErgoQIC 15US | Yes | 8202 0850 33 |

NOTE: Tool nipple is not included in the Productivity kit and needs to be order separately together with the tool.



Service Kits

GTG40 4081 0153 90
 GTR40 4081 0153 91

- LSF07 is a high speed model for precision grinding and polishing. LSF07 is delivered with a 1/8" collet and can be equipped with a 3 mm collet as optional.
- LSF12/LSV12 – Small and comfortable die grinder with up to 0.5 hp for maximum control in cramped spaces. All models are delivered with speed governor and a well balanced 1/4" Erickson collet.
- LSF19/LSV19 – All models in the 19 series are equipped with a powerful 0.67 hp air motor and a speed governor. LSF versions have scatter damping, for less vibrations. The angled models (LSV) have a patented solution that overcomes temperature and leakage problems commonly associated with angle head tools. The result is a leak free and self-cooled angle head. All models are lubrication free except for the high speed model LSF19 S460.
- LSF28 – Powerful 1.2 hp air motor, with speed governor and scatter damping. Impressive power-to-weight ratio.
- LSF38 – One of the most powerful one-hand die grinders on the market with up to 1.7 hp. If you are looking for



a tool that can boost your productivity and save you money, the LSF38 is the right tool! The die grinders in the 38

series are lubrication free with scatter damping for maximum operator comfort and safety.

| Model | Max free speed r/min | Rec max dia of | | Max output hp | Weight lb | Length in | Air consumption | | Rec. hose size | | Air inlet thread NPT | Ordering No. |
|-----------------------------------|----------------------|---------------------------|------------------|---------------|-----------|-----------|-------------------|-------------------|----------------|------|----------------------|--------------|
| | | Tungsten carbide burrs in | Mounted point mm | | | | at max output cfm | at free speed cfm | mm | in | | |
| Straight models | | | | | | | | | | | | |
| LSF12 S180-2 ^a | 18000 | 1/2 | 20 | 0.28 | 0.8 | 6.7 | 15 | 5 | 8 | 5/16 | 1/4 | 8423 0701 00 |
| LSF12 S200-2 ^a | 20000 | 1/2 | 20 | 0.32 | 0.8 | 6.7 | 17 | 5 | 8 | 5/16 | 1/4 | 8423 0701 01 |
| LSF12 S250-2 ^a | 25000 | 1/2 | 20 | 0.39 | 0.8 | 6.7 | 18 | 7 | 8 | 5/16 | 1/4 | 8423 0701 02 |
| LSF12 S310-2 ^a | 31000 | 1/2 | 20 | 0.43 | 0.8 | 6.7 | 19 | 9 | 8 | 5/16 | 1/4 | 8423 0701 03 |
| LSF12 S400-2 ^a | 40000 | 3/8 | 16 | 0.48 | 0.8 | 6.7 | 21 | 15 | 8 | 5/16 | 1/4 | 8423 0701 04 |
| LSF19 S460-2 ^a | 46000 | 3/8 | 16 | 0.68 | 1.2 | 7.6 | 24 | 31 | 10 | 3/8 | 1/4 | 8423 0703 70 |
| LSF19 S300-2 | 30000 | 1/2 | 20 | 0.67 | 1.2 | 7.6 | 23 | 14 | 10 | 3/8 | 1/4 | 8423 0703 71 |
| LSF19 S200-2 | 20000 | 1/2 | 20 | 0.67 | 1.2 | 7.6 | 20 | 7 | 10 | 3/8 | 1/4 | 8423 0703 72 |
| LSF19 S200E-2 | 30000 | 1/2 | 20 | 0.67 | 1.5 | 11.5 | 20 | 7 | 10 | 3/8 | 1/4 | 8423 0703 73 |
| LSF19 S300E-2 | 30000 | 1/2 | 20 | 0.67 | 1.5 | 11.5 | 23 | 14 | 10 | 3/8 | 1/4 | 8423 0703 74 |
| LSF28 S250-2 ^a | 25000 | 1/2 | 32 | 1.2 | 1.7 | 8.3 | 39 | 23 | 13 | 1/2 | 3/8 | 8423 0702 07 |
| LSF28 S250E-2 ^a | 25000 | 1/2 | 32 | 1.2 | 2.8 | 13.2 | 39 | 23 | 13 | 1/2 | 3/8 | 8423 0702 08 |
| LSF28 S180-2 | 18000 | 5/8 | 40 | 1.1 | 1.7 | 8.3 | 37 | 15 | 13 | 1/2 | 3/8 | 8423 0702 09 |
| LSF28 S180E-2 | 18000 | 5/8 | 40 | 1.1 | 2.7 | 13.2 | 37 | 15 | 13 | 1/2 | 3/8 | 8423 0702 10 |
| LSF28 S150-2 | 15000 | 5/8 | 40 | 0.9 | 1.7 | 8.3 | 32 | 12 | 13 | 1/2 | 3/8 | 8423 0702 15 |
| LSF28 S120-2 | 12000 | 5/8 | 40 | 0.9 | 1.7 | 8.3 | 29 | 8 | 13 | 1/2 | 3/8 | 8423 0702 16 |
| LSF38 S250E ^a | 25000 | 5/8 | 40 | 1.8 | 3.3 | 13.8 | 58 | 53 | 13 | 1/2 | 3/8 | 8423 0700 31 |
| LSF38 S180E | 18000 | 5/8 | 40 | 1.8 | 3.3 | 13.8 | 58 | 31 | 13 | 1/2 | 3/8 | 8423 0700 28 |
| LSF38 S150E | 15000 | 5/8 | 40 | 1.8 | 3.3 | 13.8 | 50 | 27 | 13 | 1/2 | 3/8 | 8423 0700 37 |
| Angle models | | | | | | | | | | | | |
| LSV12 S120-2 ^a | 12000 | 1/2 | 20 | 0.33 | 1.2 | 6.5 | 18 | 6 | 8 | 5/16 | 1/4 | 8423 0701 05 |
| LSV12 S200-2 ^a | 20000 | 1/2 | 20 | 0.39 | 1.2 | 6.5 | 20 | 14 | 8 | 5/16 | 1/4 | 8423 0701 06 |
| LSV19 S200-2 | 20000 | 1/2 | - | 0.6 | 1.3 | 7.3 | 23 | 15 | 10 | 3/8 | 1/4 | 8423 0703 75 |
| LSV19 S120-2 | 12000 | 1/2 | - | 0.6 | 1.3 | 7.3 | 23 | 15 | 10 | 3/8 | 1/4 | 8423 0703 76 |
| LSV19 S080-2 | 8000 | 1/2 | - | 0.5 | 1.3 | 7.3 | 23 | 13 | 10 | 3/8 | 1/4 | 8423 0703 77 |
| Die grinders for polishing | | | | | | | | | | | | |
| LSF28 ST030-2 | 3000 | - | - | 0.9 | 2.6 | 10.8 | 38 | 18 | 10 | 3/8 | 3/8 | 8423 0702 22 |
| LSF28 ST070-2 ^a | 7000 | - | - | 1.0 | 2.6 | 10.8 | 40 | 26 | 10 | 3/8 | 3/8 | 8423 0702 17 |
| LSF28 ST070E-2 ^a | 7000 | - | - | 1.0 | 3.9 | 15.7 | 40 | 26 | 10 | 3/8 | 3/8 | 8423 0702 18 |
| High speed model | | | | | | | | | | | | |
| LSF07 S850 ^a | 88000 | 1/6 | 6 | 0.10 | 0.9 | 6.7 | 4.9 | 4.6 | 4.5 | 3/16 | - | 8423 1222 03 |

^a Not lubrication free.
E = Extended version, flexible spindle

Accessories Included

LSF07

Air hose
ErgoNIP 08
Collet 1/8" (See ill. 1)

LSF/LSV12, LSF/LSV19, LSF28

Spanner
Collet 1/4" (See ill. 1)
Air hose, air hose nipple and clamp
Exhaust hose

LSF38

Air hose nipple
Collet 1/4" (See ill. 1)

Optional Accessories

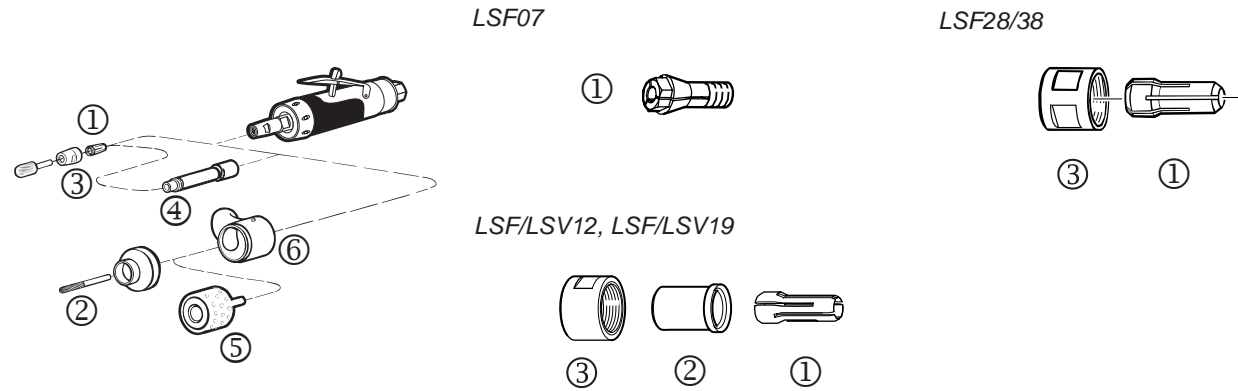

| | LSF07 | LSF/LSV12 | LSF/LSV19 | LSF28 | LSF38 | See ill. |
|---|--------------|--------------|--------------|--------------|--------------|----------|
| Optional collets | | | | | | |
| 3 mm | 4150 1800 00 | - | - | - | - | 1 |
| 1/8" | 4150 1822 00 | 4150 2226 46 | 4150 1710 00 | - | - | 1 |
| 1/4" | - | 4150 2226 03 | 4112 1077 00 | 4150 1709 00 | 4150 1709 00 | 1 |
| 3/8" | - | - | - | - | 4150 1708 00 | 1 |
| Collar | - | 4150 2226 02 | 4112 1078 00 | - | - | 2 |
| Collet nut | - | 4150 2226 04 | 4112 1076 00 | 4150 1706 00 | 4150 1706 00 | 3 |
| For machining of plastic and glas fibre | | | | | | |
| Spot suction kit burr (burr not included) | - | 3780 3015 23 | 3780 3015 22 | 3780 4007 42 | - | 6 |
| Diamond burr Ø 6 mm (1/4") | - | 3780 5013 70 | 3780 5013 70 | 3780 5013 70 | - | 2 |
| Spot suction kit drum (drum not included), for use with 8 mm (5/16") collet | - | - | 3780 4011 61 | 3780 4011 73 | - | 6 |
| Diamond drum Ø 52 mm (2 1/16") | - | - | 3780 5033 00 | 3780 5035 00 | - | 5 |

Productivity Kits

| Model | Max air flow | Hose 16.4 ft | Coupling | Lubrication | Ordering No. |
|--------------------------------|--------------|--------------|--------------|-------------|--------------|
| MIDI Optimizer F/RD EQ10US-T13 | 65 cfm | Turbo 13 | ErgoQIC 10US | Yes | 8202 0850 29 |
| MIDI Optimizer F/R EQ10US-T13 | 65 cfm | Turbo 13 | ErgoQIC 10US | No | 8202 0850 30 |

NOTE: Tool nipple is not included in the Productivity kit and needs to be order separately together with the tool.



Service Kits

| | |
|-----------|--------------|
| 07 series | 4081 0243 90 |
| 12 series | 4081 0472 90 |
| 19 series | 4081 0488 90 |
| 28 series | 4081 0315 90 |
| 38 series | 4081 0308 90 |

Atlas Copco straight grinders for cone wheel or collet, are suitable for grinding in holes and cavities in castings, etc. They require rough abrasives, which must be attached to the tool with a rigid shank or be mounted directly to the spindle.

The power ranges from 0.9 hp to 2.4 hp. All Atlas Copco tools are designed with focus on operator ergonomics and maximum power, the best combination for maximum productivity.

- The LSR38 is suitable for lighter applications where accessibility is first priority.
- If you need maximum power, then LSR48 is the natural choice. You will have access to 2.4 hp in combination with auto balancer for even less vibrations. All packed in a strong and light package.



LSR38 CW



LSR48 CW

| Model | Max free speed r/min | Rec. wheel diameter in | Max output hp | Weight lb | Length in | Air consumption | | Rec. hose size in | Spindle thread and length in | Air inlet thread NPT | Ordering No. |
|-----------------|----------------------|------------------------|---------------|-----------|-----------|-------------------|-------------------|-------------------|------------------------------|----------------------|--------------|
| | | | | | | at max output cfm | at free speed cfm | | | | |
| LSR38 S150-CW | 15000 | 2 3/8 | 1.8 | 3.5 | 12.6 | 50 | 27 | 1/2 | UNF 3/8x14 | 3/8 | 8423 0700 29 |
| LSR38 S180-CW | 18000 | 2 | 1.8 | 3.5 | 12.6 | 58 | 31 | 1/2 | UNF 3/8x14 | 3/8 | 8423 0700 30 |
| LSR38 S150-CW/2 | 15000 | 2 3/8 | 1.8 | 3.5 | 12.6 | 50 | 27 | 1/2 | UNC 5/8x21 | 3/8 | 8423 0700 33 |
| LSR38 S120-CW/2 | 12000 | 2 | 1.8 | 3.5 | 12.6 | 58 | 31 | 1/2 | UNC 5/8x21 | 3/8 | 8423 0700 35 |
| LSR48 S120-CW | 12000 | 2 | 2.4 | 5.0 | 17.6 | 64 | 28 | 1/2 | UNC 5/8x21 | 1/2 | 8423 0708 02 |

Accessories Included

LSR38 CW

Exhaust air hose (1.1 ft)
 Hose clamp
 Open end spanner
 For -CW: UNF 3/8" (See ill. 1)
 For -CW/2: UNC/W 5/8" (See ill. 1)

LSR48 CW

Whip hose
 Wrench
 Cone wheel adapter UNC 5/8"-11,
 (See ill. 2)

Optional Accessories

LSR38

| | See illustration | Ordering No. |
|---|------------------|--------------|
| Adapter for cone wheel with thread | | |
| UNC/W 3/8" | 1 | 4150 0318 00 |
| UNF 3/8" | 1 | 4150 0318 01 |
| UNC 1/2" | 1 | 4150 1357 00 |
| UNC/W 5/8" | 1 | 4150 0767 00 |

LSR48

| | See illustration | Ordering No. |
|---|------------------|--------------|
| Adapter for cone wheel with thread | | |
| UNC/W 5/8" | 2 | 4150 0945 01 |

LSR38-CW

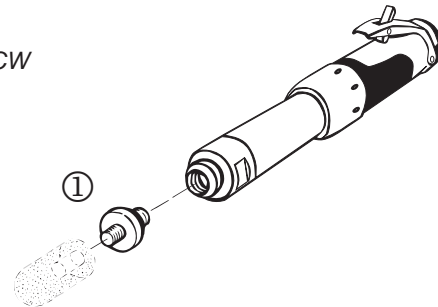

LSR48-CW

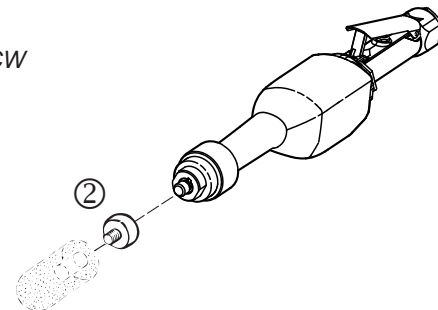

Productivity Kits

| Model | Max air flow | Hose 16.4 ft | Coupling | Lubrication | Ordering No. |
|--------------------------------|--------------|--------------|--------------|-------------|--------------|
| MIDI Optimizer F/RD EQ10US-T13 | 65 cfm | Turbo 13 | ErgoQIC 10US | Yes | 8202 0850 29 |
| MIDI Optimizer F/R EQ10US-T13 | 65 cfm | Turbo 13 | ErgoQIC 10US | No | 8202 0850 30 |

NOTE: Tool nipple is not included in the Productivity kit and needs to be order separately together with the tool.



Service Kits

| | |
|-----------|--------------|
| 28 series | 4081 0315 90 |
| 38 series | 4081 0311 90 |
| 48 series | 4081 2023 90 |

No matter which of our vane grinders you choose you will get durable tools with high power and low weight. In addition, vibrations and noise are on a low level.

- LSV19 – For work in cramped spaces, the LSV19 series is small yet powerful, and lubrication free.
Features: Speed governor, sealed angle head, thermally insulated handle and lubrication-free air motor.
- LSV28 – Small, yet powerful giving 1 hp. Available in an extended version for optimal accessibility.
Features: Speed governor and thermally insulated handle.
- LSV38 – If you are looking for the most powerful one-hand grinder on the market, then you have found it – up to 1.7 hp.
Features: Speed governor, sealed angle head, lubrication-free air motor, thermally insulated handle, spindle lock and adjustable wheel guard.
- LSV48 – Our most powerful angle vane grinder with 2.5 hp for ultimate productivity.
Features: Speed governor, sealed angle head, lubrication-free air motor, thermally insulated handle and spindle lock. The autobalancer reduces the vibrations by up to 50%.



| Model | Max free speed r/min | Max wheel dia in | Max output hp | Weight lb | Height over spindle in | Air consumption | | Spindle thread and length in | Hose size in | Air inlet thread NPT | Ordering No. |
|-----------------|----------------------|------------------|---------------|-----------|------------------------|-------------------|-------------------|------------------------------|--------------|----------------------|--------------|
| | | | | | | at max output cfm | at free speed cfm | | | | |
| LSV19 S170-327 | 17000 | 3 | 0.6 | 1.6 | 2.8 | 23 | 14 | UNF 3/8x17 | 3/8 | 1/4 | 8423 0705 80 |
| LSV28 ST13-427E | 13000 | 4 | 1.0 | 3.7 | 3.1 | 37 | 16 | UNF 3/8x17 | 3/8 | 3/8 | 8423 0706 00 |
| LSV28 ST12-427 | 12000 | 4 | 1.0 | 3.7 | 3.2 | 37 | 16 | UNF 3/8x18 | 3/8 | 3/8 | 8423 0706 01 |
| LSV38 ST12-427 | 12000 | 4 | 1.7 | 3.5 | 3.3 | 58 | 31 | UNF 3/8x17 | 1/2 | 3/8 | 8423 0700 20 |
| LSV38 ST12-527 | 12000 | 4 1/2-5 | 1.7 | 4.0 | 3.3 | 58 | 31 | UNC 5/8x20 | 1/2 | 3/8 | 8423 0700 22 |
| LSV48 SA120-527 | 12000 | 5 | 2.5 | 5.5 | 3.9 | 76 | 36 | UNC 5/8x21 | 5/8 | 1/2 | 8423 0707 53 |
| LSV48 SA085-727 | 8500 | 7 | 2.5 | 6.2 | 3.9 | 76 | 36 | UNC 5/8x21 | 5/8 | 1/2 | 8423 0707 52 |
| LSV48 SA066-727 | 6600 | 7 | 2.5 | 5.1 | 3.9 | 76 | 36 | UNC 5/8x21 | 5/8 | 1/2 | 8423 0707 54 |

With wheel guard for disc
 -327 = Ø 3"
 -427 = Ø 4"
 -527 = Ø 5" and 4.5"
 -727 = Ø 7"

Selection Guide

HOW TO CHOOSE YOUR LSV38

| | LSV38 ST12-427 | LSV38 ST12-527 |
|----------------------------|----------------|----------------|
| 1.7 hp air motor | x | x |
| Adjustable guard positions | x | x |
| Lockable spindle | x | x |
| Side handle | x | x |
| Size wheel, inch | 4 | 4.5 and 5 |
| Spindle thread, inch | UNF 3/8 | UNC 5/8 |

Accessories Included

LSV19

Wheel guard
Flanges
Air hose nipple, clamp
Wrenches
Exhaust hose set

LSV28

Wheel guard
Flanges
Air hose, air hose nipple, clamp
Wrenches
Exhaust hose set

LSV38

Wheel guard
Flanges
Support handle (LSV38 ST-models)
Wrenches
Grease refill

LSV48

Wheel guard
Flanges
Support handle
Wrenches
Grease refill

LSV19



LSV38

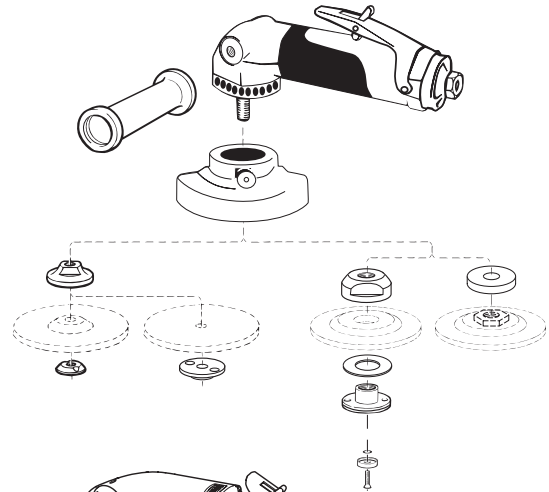

LSV28

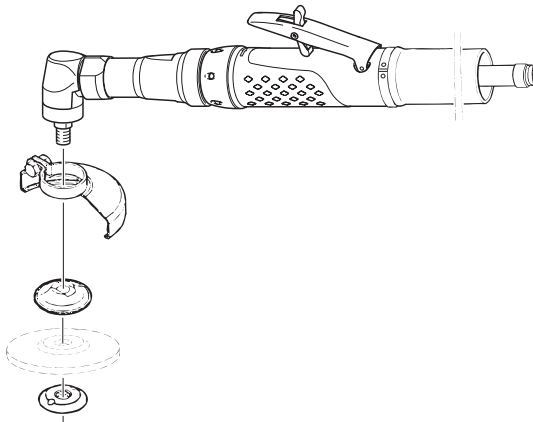

LSV48

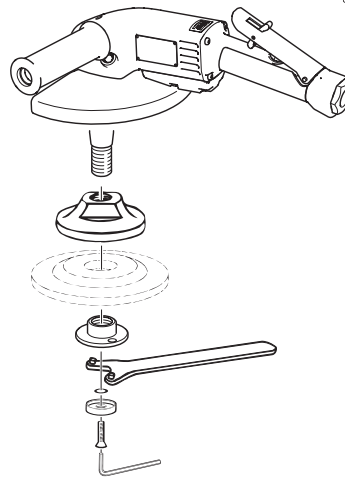

Productivity Kits

| Model | Max air flow | Hose 16.4 ft | Coupling | Lubrication | Ordering No. |
|--------------------------------|--------------|--------------|--------------|-------------|--------------|
| MIDI Optimizer F/RD EQ10US-T13 | 65 cfm | Turbo 13 | ErgoQIC 10US | Yes | 8202 0850 29 |
| MIDI Optimizer F/R EQ10US-T13 | 65 cfm | Turbo 13 | ErgoQIC 10US | No | 8202 0850 30 |
| MIDI Optimizer F/RD EQ15US-T16 | 85 cfm | Turbo 16 | ErgoQIC 15US | Yes | 8202 0850 31 |
| MAXI F/R EQ15US-T20 | 140 cfm | Turbo 16 | ErgoQIC 15US | No | 8202 0850 32 |
| MAXI F/RD EQ15US-T20 | 140 cfm | Turbo 16 | ErgoQIC 15US | Yes | 8202 0850 33 |

NOTE: Tool nipple is not included in the Productivity kit and needs to be order separately together with the tool.



Service Kits

| | |
|-------|--------------|
| LSV19 | 4081 0488 90 |
| LSV28 | 4081 0317 90 |
| LSV38 | 4081 0309 90 |
| LSV48 | 4081 0312 90 |

- LSV12 series** – For finer work where less power and more control are needed. Available with collet or threaded spindle. Features: Speed governor, high quality gears and lever with feathering characteristics.
- LSV19 series** – For work in cramped spaces. Available with collet or threaded spindle versions. Features: Speed governor, sealed angle head and lubrication-free air motor.
- LSV28 series** – The 28 series comes in various speeds. Features: Speed governor, sealed angle head, LF models have lubrication-free air motor.
- LSV38 series** – Powerful one hand sander for medium rough to rough sanding. Features: Speed governor, sealed angle head, lubrication-free air motor and spindle lock.
- LSV48 series** – Our most powerful angle vane sander with 2.5 hp for ultimate productivity. Features: Speed governor, sealed angle head, lubrication-free air motor, autobalancer and spindle lock.



| Model | Max free speed r/min | Rec. pad size dia in | Max output hp | Weight lb | Length in | Height in | Air consumption | | Spindle thread and length in | Rec. hose size in | Air inlet thread NPT | Ordering No. |
|------------------------------|----------------------|----------------------|---------------|-----------|-----------|-----------|-------------------|-------------------|------------------------------|-------------------|----------------------|--------------|
| | | | | | | | at max output cfm | at free speed cfm | | | | |
| With collet | | | | | | | | | | | | |
| LSV12 S200-2 | 20000 | 2 | 0.39 | 1.2 | 6.5 | 3.0 | 17.6 | 6.4 | – ^a | 5/16 | 1/4 | 8423 0701 06 |
| LSV12 S120-2 | 12000 | 3 | 0.33 | 1.2 | 6.5 | 3.0 | 17.6 | 6.4 | – ^a | 5/16 | 1/4 | 8423 0701 05 |
| LSV19 S200-2 | 20000 | 2 | 0.6 | 1.3 | 7.3 | 3.0 | 23 | 15 | – ^a | 3/8 | 1/4 | 8423 0703 75 |
| LSV19 S120-2 | 12000 | 3 | 0.6 | 1.3 | 7.3 | 3.0 | 23 | 15 | – ^a | 3/8 | 1/4 | 8423 0703 76 |
| LSV19 S080-2 | 8000 | 3 | 0.5 | 1.3 | 7.3 | 3.0 | 23 | 13 | – ^a | 3/8 | 1/4 | 8423 0703 77 |
| With threaded spindle | | | | | | | | | | | | |
| LSV12 S200 | 20000 | 2 | 0.39 | 1.2 | 6.5 | 2.3 | 17.6 | 6.4 | UNC 1/4x5/16 | 5/16 | 1/4 | 8423 0701 08 |
| LSV12 S120 | 12000 | 3 | 0.33 | 1.2 | 6.5 | 2.3 | 17.6 | 6.4 | UNC 1/4x5/16 | 5/16 | 1/4 | 8423 0701 07 |
| LSV19 S120 | 12000 | 3 | 0.6 | 1.3 | 7.3 | 2.3 | 23 | 15 | UNC 1/4x8 | 3/8 | 1/4 | 8423 0703 78 |
| Dry sanding | | | | | | | | | | | | |
| LSV28 S085 | 8500 | 7 | 1.0 | 3.2 | 10.4 | 3.4 | 46 | 29 | UNC 5/8x32 | 3/8 | 3/8 | 8423 0706 12 |
| LSV28 S060 LF | 6000 | 7 | 1.0 | 3.2 | 10.4 | 3.4 | 34 | 16 | UNC 5/8x32 | 3/8 | 3/8 | 8423 0706 11 |
| LSV28 S040 LF | 4000 | 7 | 0.8 | 3.2 | 10.4 | 3.4 | 32 | 9 | UNC 5/8x32 | 3/8 | 3/8 | 8423 0706 13 |
| LSV28 ST034 | 3400 | 7 | 1.0 | 3.7 | 12.0 | 3.4 | 38 | 16 | UNC 5/8x32 | 3/8 | 3/8 | 8423 0706 15 |
| LSV28 S021 LF | 2100 | 7 | 0.9 | 4.1 | 11.2 | 3.4 | 34 | 12 | UNC 5/8x32 | 3/8 | 3/8 | 8423 0706 14 |
| LSV38 S085 | 8500 | 7 | 1.7 | 3.5 | 8.5 | 3.8 | 58 | 31 | UNC 5/8x23 | 1/2 | 3/8 | 8423 0700 24 |
| LSV38 S066 | 6600 | 7 | 1.6 | 3.5 | 8.5 | 3.8 | 50 | 27 | UNC 5/8x23 | 1/2 | 3/8 | 8423 0700 25 |
| LSV38 S066 D | 6600 | 7 | 1.6 | 3.5 | 8.5 | 3.8 | 50 | 27 | UNC 5/8x28 | 1/2 | 3/8 | 8423 0700 26 |
| LSV48 SA066 | 6600 | 7 | 2.5 | 5.1 | 11.8 | 3.5 | 76 | 36 | UNC 5/8x21 | 5/8 | 1/2 | 8423 0707 50 |
| LSV48 SA085 | 8500 | 7 | 2.5 | 5.1 | 11.8 | 3.5 | 76 | 36 | UNC 5/8x21 | 5/8 | 1/2 | 8423 0707 51 |

Backing pads sold separately.

^a Ø 1/4" collet.

- D = Spot suction kit included.

Accessories Included

Air hose nipple Support handle (LSV28/38/48)
 Clamp Wrenches (LSV19/28)
 Exhaust hose (LSV19/28/38) Spot suction equipment (D-version)

Optional Accessories

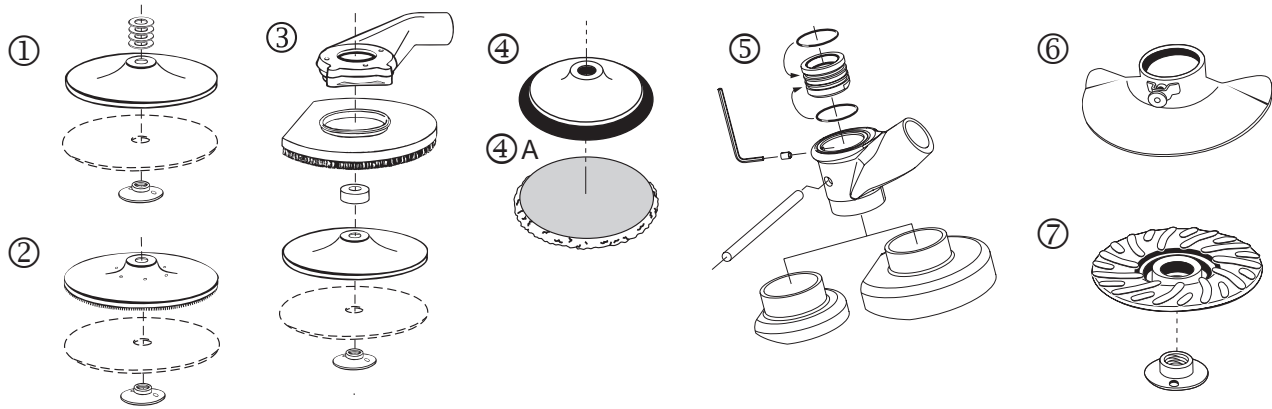

| | LSV12 | LSV19 | LSV28 | LSV38 | LSV48 | See illustration |
|---|---------------------------|--|---------------------------|--------------|--------------|------------------|
| Backing pad set, standard type | | | | | | |
| Ø 5 in - 5/8" - soft | - | - | 4170 0768 80 | 4170 0768 80 | 4170 0768 80 | 1 |
| Ø 7 in - 5/8" - soft | - | - | 4170 0756 80 | 4170 0756 80 | 4170 0756 80 | 1 |
| Ø 7 in - 5/8" - stiff | - | - | 4170 0757 80 | 4170 0757 80 | 4170 0757 80 | 1 |
| Backing pad set with cooling ribs | | | | | | |
| Ø 5 in - 5/8" and M14 | - | - | 4150 1962 80 | 4150 1962 80 | 4150 1962 80 | 2 |
| Ø 7 in - 5/8" and M14 | - | - | 4150 1962 81 | 4150 1962 81 | 4150 1962 81 | 2 |
| Backing pad set, heavy duty type | | | | | | |
| Ø 120 mm - 5/8" | - | - | - | 4170 1204 90 | 4170 1204 90 | 7 |
| Ø 162 mm - 5/8" | - | - | - | 4170 1192 90 | 4170 1192 90 | 7 |
| Backing pad set for polishing - velcro | | | | | | |
| Ø 150 mm - 5/8" (max 2500 rpm) | - | - | 4112 6092 15 | - | - | 4 |
| Ø 150 mm - Lambs woll bonnet | - | - | 4112 6093 15 | - | - | 4A |
| Spot suction kit for fiber disc | | | | | | |
| Ø 5 in | - | - | 3780 4007 80 ^a | - | - | 3 |
| Ø 7 in | - | - | 3780 4007 90 ^b | - | 3780 4093 40 | |
| | | | 3780 4031 60 ^c | | | |
| Ø 2 - 3 in | 3780 4092 64 ^d | 3780 4092 62 ^d 3780 4092 65 ^e | - | - | - | 5 |
| Hand shield for 5-7 in | - | - | - | 4150 1936 80 | - | 6 |
| Hand shield for 5-7 in, large shield | - | - | - | 4150 1941 80 | - | 6 |

^a = Suits LSV28 S060 ^b = Suits LSV28 S040/060 ^c = Suits LSV28 S021 ^d = For model with collet ^e = For model with threaded spindle

Productivity Kits

| Model | Max air flow | Hose 16.4 ft | Coupling | Lubrication | Ordering No. |
|--------------------------------|--------------|--------------|--------------|-------------|--------------|
| MIDI Optimizer F/RD EQ10US-T13 | 65 cfm | Turbo 13 | ErgoQIC 10US | Yes | 8202 0850 29 |
| MIDI Optimizer F/R EQ10US-T13 | 65 cfm | Turbo 13 | ErgoQIC 10US | No | 8202 0850 30 |
| MIDI Optimizer F/RD EQ15US-T16 | 85 cfm | Turbo 16 | ErgoQIC 15US | Yes | 8202 0850 31 |
| MAXI F/R EQ15US-T20 | 140 cfm | Turbo 16 | ErgoQIC 15US | No | 8202 0850 32 |
| MAXI F/RD EQ15US-T20 | 140 cfm | Turbo 16 | ErgoQIC 15US | Yes | 8202 0850 33 |

NOTE: Tool nipple is not included in the Productivity kit and needs to be order separately together with the tool.



Service Kits

| | |
|-------|--------------|
| LSV19 | 4081 0488 90 |
| LSV28 | 4081 0317 90 |
| LSV38 | 4081 0309 90 |
| LSV48 | 4081 0312 90 |

Orbital and Random Orbital Sanders

Atlas Copco series of random orbital sanders combines all the important customer and application requirements in a very competitive range of products. Applications like sanding before painting and surface coating, polishing with wax and surface conditioner are all quickly done with the small and easily operated LST20-range of sanders.

All models are lubrication free and have silicone free components. They have two grip options in the same handle. In addition, one smaller grip model is included. The full range includes standard models and extraction models. There are also two orbit diameters to choose from in the model range.

- **Lubrication-free** – Avoids contamination of workpiece. No oil in the exhaust air.



| Model | Max free speed r/min | Pad size mm | Orbit dia mm | Max output hp | Weight lb | Height mm | Length mm | Air consumption at free speed cfm | Rec. hose size mm | Air inlet thread NPT | Ordering No. |
|---|----------------------|-------------|--------------|---------------|-----------|-----------|------------------|-----------------------------------|-------------------|----------------------|--------------|
| Random orbital – Standard | | | | | | | | | | | |
| LST30 H090-11 | 9000 | 110 | 8 | 0.4 | 2.6 | 120 | 255 | 16 | 8 | 1/4 | 8423 0361 64 |
| LST30 H090-15 | 9000 | 150 | 8 | 0.4 | 2.6 | 120 | 275 | 16 | 8 | 1/4 | 8423 0361 72 |
| LST30 S090-15 | 9000 | 150 | 8 | 0.4 | 2.4 | 120 | 175 | 16 | 8 | 1/4 | 8423 0361 98 |
| Self suction^a | | | | | | | | | | | |
| LST31 H090-15 | 9000 | 150 | 8 | 0.4 | 3.0 | 120 | 300 | 16 | 8 | 1/4 | 8423 0363 19 |
| Central suction^b | | | | | | | | | | | |
| LST32 H090-15 | 9000 | 150 | 8 | 0.4 | 3.0 | 120 | 300 | 16 | 8 | 1/4 | 8423 0362 55 |
| LST32 S090-15 | 9000 | 150 | 8 | 0.4 | 2.9 | 120 | 200 | 16 | 8 | 1/4 | 8423 0362 71 |
| Orbital – Standard | | | | | | | | | | | |
| LSO30 S070-3 | 7000 | 93x170 | 5 | 0.4 | 3.5 | 125 | 185 | 16 | 8 | 1/4 | 8423 0360 16 |
| LSO30 H070-3 | 7000 | 93x170 | 5 | 0.4 | 3.7 | 125 | 285 | 16 | 8 | 1/4 | 8423 0360 24 |
| Self suction^a | | | | | | | | | | | |
| LSO31 S070-3 | 7000 | 93x170 | 5 | 0.4 | 3.5 | 125 | 210 | 16 | 8 | 1/4 | 8423 0362 79 |
| LSO31 H070-3 | 7000 | 93x170 | 5 | 0.4 | 3.7 | 125 | 310 | 16 | 8 | 1/4 | 8423 0363 03 |
| Central suction^c | | | | | | | | | | | |
| LSO32 H070-3 | 7000 | 93x170 | 5 | 0.4 | 4.0 | 125 | 310 | 16 | 8 | 1/4 | 8423 0361 07 |
| Standard model | | | | | | | | | | | |
| LST20 R350 | 12000 | 90 | 5 | 0.27 | 1.85 | 95 | 127 | 17 | 8 | 1/4 | 8423 0361 65 |
| LST20 R550 | 12000 | 125 | 5 | 0.27 | 1.85 | 83 | 127 | 17 | 8 | 1/4 | 8423 0361 69 |
| LST20 R650 | 12000 | 150 | 5 | 0.27 | 1.85 | 83 | 127 | 17 | 8 | 1/4 | 8423 0361 73 |
| LST20 R525 | 12000 | 125 | 2.4 | 0.27 | 1.85 | 83 | 127 | 17 | 8 | 1/4 | 8423 0361 81 |
| LST20 R625 | 12000 | 150 | 2.4 | 0.27 | 1.85 | 83 | 127 | 17 | 8 | 1/4 | 8423 0361 84 |
| Extraction model – self suction | | | | | | | | | | | |
| LST21 R350 | 12000 | 90 | 5 | 0.27 | 1.85 | 95 | 133 ^d | 17 | 8 | 1/4 | 8423 0361 66 |
| LST21 R550 | 12000 | 125 | 5 | 0.27 | 1.85 | 83 | 133 ^d | 17 | 8 | 1/4 | 8423 0361 70 |
| LST21 R650 | 12000 | 150 | 5 | 0.27 | 1.85 | 83 | 133 ^d | 17 | 8 | 1/4 | 8423 0361 74 |
| LST21 R525 | 12000 | 125 | 2.4 | 0.27 | 1.85 | 83 | 133 ^d | 17 | 8 | 1/4 | 8423 0361 82 |
| LST21 R625 | 12000 | 150 | 2.4 | 0.27 | 1.85 | 83 | 133 ^d | 17 | 8 | 1/4 | 8423 0361 85 |
| Extraction model – central suction^c | | | | | | | | | | | |
| LST22 R350 | 12000 | 90 | 5 | 0.27 | 1.85 | 95 | 133 ^d | 17 | 8 | 1/4 | 8423 0361 67 |
| LST22 R550 | 12000 | 125 | 5 | 0.27 | 1.85 | 83 | 133 ^d | 17 | 8 | 1/4 | 8423 0361 71 |
| LST22 R650 | 12000 | 150 | 5 | 0.27 | 1.85 | 83 | 133 ^d | 17 | 8 | 1/4 | 8423 0361 75 |
| LST22 R650-9 | 12000 | 150 | 5 | 0.27 | 1.85 | 83 | 133 ^d | 17 | 8 | 1/4 | 8423 0361 40 |
| LST22 R325 | 12000 | 90 | 2.4 | 0.27 | 1.85 | 95 | 133 ^d | 17 | 8 | 1/4 | 8423 0361 78 |
| LST22 R525 | 12000 | 125 | 2.4 | 0.27 | 1.85 | 83 | 133 ^d | 17 | 8 | 1/4 | 8423 0361 83 |
| LST22 R625 | 12000 | 150 | 2.4 | 0.27 | 1.85 | 83 | 133 ^d | 17 | 8 | 1/4 | 8423 0361 86 |

^a Includes dust collecting bag.

^b Required air flow 150 m³/h or 88 cfm.

^c Required air flow 60 m³/h or 35 cfm.

^d 186 mm (7.3") suction hose connector included.

H = With handle.

S = Without handle.

All data at 6.3 bar.

-9 Velcro pad, 9 holes.

Accessories Included

LSO

Base pad
Perforating plate
Hose nipple for 8 mm hose
LSO31 including dust collection kit

LST20/21/22

Velcro pad
U-wrench for pad change
Air hose nipple
Dust hose and bag (LST21)
Large and small grip cover

LST30/31/32

Velcro pad
Bar for changing pad
Hose nipple for 8 mm hose
LST31 incl dust collection kit

Optional Accessories

LSO

| For LSO | Ordering No. |
|---|--------------|
| Base pad, vinyl for -3F-type | 4112 0787 01 |
| Suspension yoke | 4112 0975 00 |
| Hose set Dust hose, for LSO32, Ø 32 mm, L=1.8 m including air hose | 3780 2724 34 |

LST20/21/22, PAD FOR SELF STICK PAPER

| | Ordering No. | | |
|--------------|--------------|--------------|--------------|
| | Dia 89 mm | Dia 125 mm | Dia 150 mm |
| For LST20 | 4112 1231 00 | 4112 1233 00 | 4112 1235 00 |
| For LST21/22 | | 4112 1232 00 | 4112 1234 00 |

LST20/21/22, PAD FOR VELCRO BACK PAPER

| | Ordering No. | | |
|---------------|--------------|--------------|--------------|
| | Dia 89 mm | Dia 125 mm | Dia 150 mm |
| For LST 20 | 4112 1218 00 | 4112 1216 00 | 4112 1214 00 |
| For LST 21/22 | - | 4112 1217 00 | 4112 1215 00 |

LST30/31/32

| | Ordering No. |
|--|---------------------------|
| Pad velcro, Ø 150 mm | 4112 0795 01 ^a |
| Pad velcro, Ø 110 mm | 4112 0792 02 ^b |
| Pad velcro, Ø 150 mm, 6 holes | 4112 0796 00 ^c |
| Suspension yoke | 4112 0975 00 |
| Hose set Dust hose Ø 32 mm, L=1.8 m including air hose | 3780 2724 34 ^d |

^aLST30-15 ^bLST30/32-11 ^cLST31/32-15 ^dLST32

LST30/31/32, PAD FOR SELF STICK PAPER

| | Ordering No. | | |
|---------------|---------------|--------------|--------------|
| | Dia 110 mm | Dia 125 mm | Dia 150 mm |
| For LST 30 | 41120 7992 00 | 4112 0872 00 | 4112 0793 00 |
| For LST 31/32 | 41120 7992 00 | 4112 0873 00 | 4112 0874 00 |



Service Kits

LST20/21/22 4112 1300 90

238 Grinders

LSO

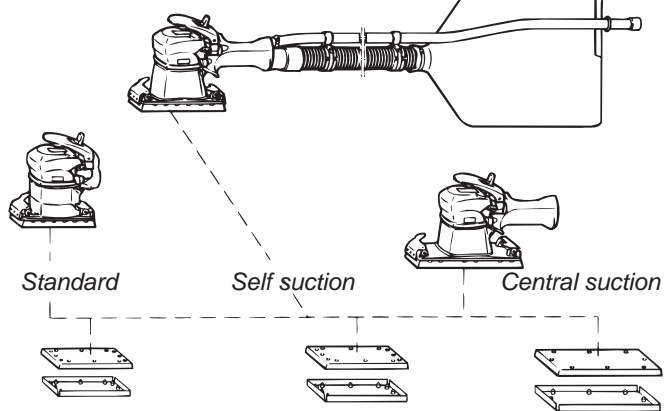

LST

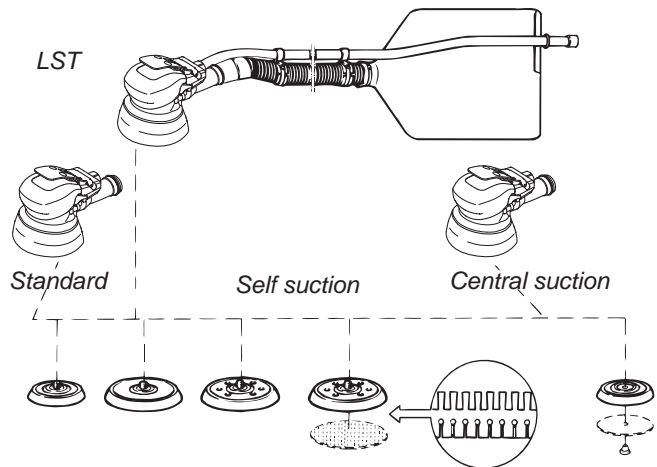

HOLE PATTERN DIMENSIONS FOR SANDING PAPER, DUST EXTRACTION MODELS

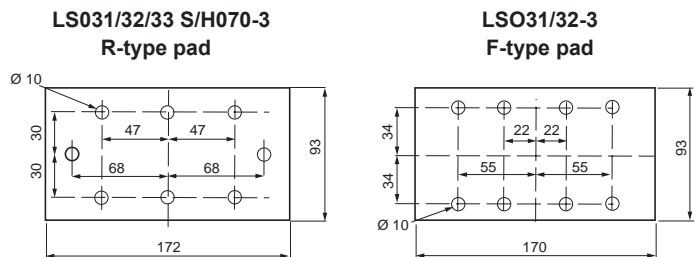

LST20/21/22, 30/31/32

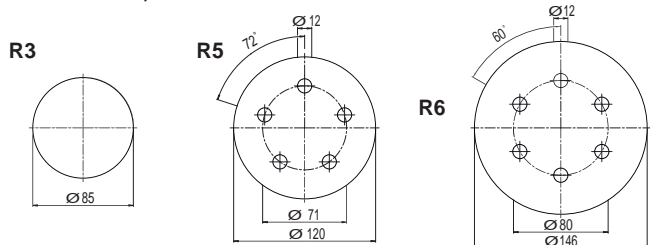

Dimension in mm

The fact that dust can represent a hazard in the working environment is well documented.

Dust particles from certain materials are dangerous to health. Even inert dust particles that cause no permanent damage can still be retained in the body and make breathing more difficult. The size of dust particles of most concern are those below 0.005 mm.

Efficient dust control can make a significant contribution to efficiency and productivity in industrial operations. It is already a requirement in countries with strict health and safety regulations.

Efficient dust control will:

- Reduce the health risk for operators exposed to potentially dangerous particles.
- Give a more favourable working environment which will encourage greater efficiency and effort from those who operate industrial tools.

The most efficient method of dust collection is dust extraction at the point of dust creation, i.e. on the tool itself. This not only ensures very efficient extraction but also allows a relatively low power vacuum source to be used.

Atlas Copco spot suction kits provide an extraction hood fixed to the tool. It is fitted with a plastic or brush edge to trap heavier particles as well as the small ones. The following pages show a number of applications and the necessary dust extraction kits with their contents.



LSV28/38/48/GTG40

SPOT SUCTION KIT FOR SANDING WITH FIBER DISC. SANDERS WITH UNC 5/8" SPINDLE.

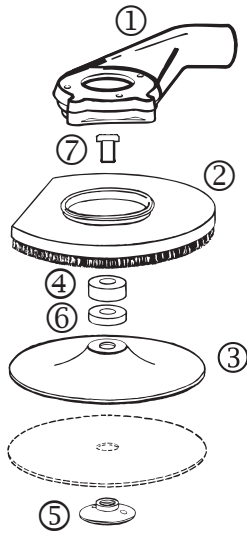

Suction requirement: 250 m³/h

| | | Ordering No. | |
|---------------------------|----------|---------------------------------|--------------|
| LSV28 S040/S060/S085 5 in | Includes | KIT | |
| | | 1 Chamber | 3780 4007 80 |
| | | 2 Suction cap 125 mm with brush | 3780 3100 40 |
| | | 3 Backing pad 125 mm | 3780 2650 20 |
| | | 4 Distance washer 12 mm | 3780 2710 30 |
| LSV28 ST12-13 5 in | Includes | KIT | |
| | | 1 Chamber | 3780 2721 60 |
| | | 2 Suction cap 125 mm with brush | 3780 2722 00 |
| | | 3 Backing pad 125 mm | 3780 4008 60 |
| | | 6 Distance washer 9 mm | 3780 3101 10 |
| LSV28 S040/S060 7 in | Includes | KIT | |
| | | 1 Chamber | 3780 2650 20 |
| | | 2 Suction cap 180 mm with brush | 3780 2710 30 |
| | | 3 Backing pad 180 mm | 3780 2721 50 |
| | | 6 Distance washer 9 mm | 4021 0457 00 |
| LSV28 S021 7 in | Includes | KIT | |
| | | 1 Chamber | 3780 2722 00 |
| | | 2 Suction cap 180 mm with brush | 3780 4007 90 |
| | | 3 Backing pad 180 mm | 3780 3100 40 |
| | | 6 Distance washer 9 mm | 3780 2675 00 |
| LSV38 S066 7 in | Includes | KIT | |
| | | 1 Chamber | 3780 2710 60 |
| | | 2 Suction cap 180 mm with brush | 3780 2721 60 |
| | | 3 Backing pad 180 mm | 3780 2726 70 |
| | | 6 Distance washer 9 mm | 3780 4031 60 |
| LSV38 S085 5 in | Includes | KIT | |
| | | 1 Chamber | 3780 3101 50 |
| | | 2 Suction cap 125 mm with brush | 3780 2675 00 |
| | | 3 Backing pad 125 mm | 3780 2710 60 |
| | | 6 Distance washer 9 mm | 3780 2721 60 |
| LSV48 SA066 7 in | Includes | KIT | |
| | | 1 Chamber | 3780 2726 70 |
| | | 2 Suction cap 180 mm with brush | 3780 4008 84 |
| | | 3 Backing pad 180 mm | 3780 3103 52 |
| | | 6 Distance washer 9 mm | 3780 2675 00 |
| GTG40 S060 7 in | Includes | KIT | |
| | | 1 Chamber | 3780 2710 60 |
| | | 2 Suction cap 180 mm with brush | 3780 2721 50 |
| | | 3 Backing pad 180 mm | 3780 2726 70 |
| | | 6 Distance washer 9 mm | 3780 2721 50 |

^a Use with adapter, Ordering No. 4150 1928 90, to be ordered separately.

VACUUM HOSE, 5.9 FT

| Hose | Ordering No. |
|---|--------------|
| Ø 1" (25 mm) for 74 cfm (125 m ³ /h) suction requirement | 3780 2724 20 |
| Ø 1 9/32" (32 mm) for 118 cfm (200 m ³ /h) suction requirement | 3780 2724 31 |
| Ø 1 1/2" (38 mm) for 147 cfm (250 m ³ /h) suction requirement | 3780 2724 40 |

BRUSH FOR SUCTION CAP

| | Ordering No. |
|---|--------------|
| Separate brush 3/4" high, for cap Ø 5" | 3780 2678 00 |
| Separate brush 3/4" high, for cap Ø 7" | 3780 2677 50 |
| Separate brush 1 3/16" high, for cap Ø 7" | 3780 2677 30 |

SPOT SUCTION KIT FOR DIE GRINDERS

Suction requirement: 125 m³/h (LSF19), 200 m³/h (LSF28)

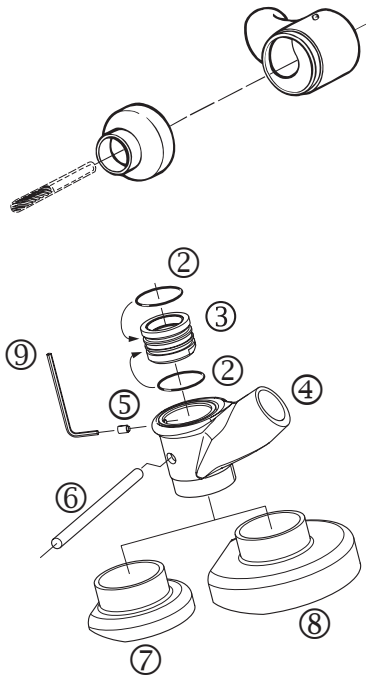

| | | Ordering No. |
|-----------|---|--------------|
| LSV12 S-1 | KIT for sanding pad dia 2-3" | 3780 4092 64 |
| LSF19 S | KIT for burr | 3780 3015 22 |
| | Optional Diamond burr 6 mm | 3780 5013 70 |
| LSF19 S | KIT for drum | 3780 4011 61 |
| | Includes 3 Shaft dia 6 mm | 3780 5090 30 |
| | 4 Locking screw | 3780 5090 60 |
| | Optional 5 Diamond drum 27 mm | 3780 5033 00 |
| LSV19 S-1 | KIT for sanding pad dia 50 and 75 mm | 3780 4092 62 |
| | Includes 6 O-ring 23x1.6 | 0663 2103 85 |
| | 7 Clamp ring | 4112 1065 04 |
| | 9 Lock screw M4x6 A1 | 0192 1168 00 |
| | 10 Lock pin | 4112 0779 00 |
| LSF28 | KIT for burr | 3780 4007 42 |
| | Optional Diamond burr 6 mm | 3780 5013 70 |

LSV48

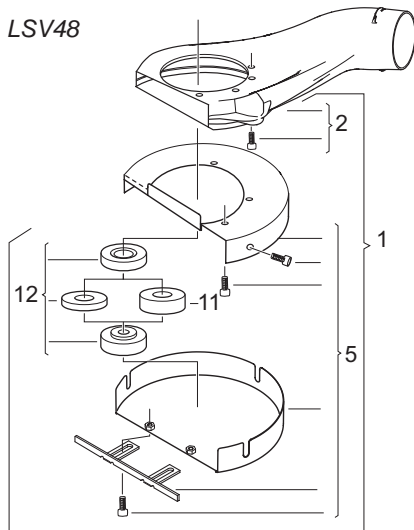

DUST EXTRACTION FOR DIAMOND CUTTING BLADE (GRP-CUTTING)

| | | Ordering No. |
|------------------------|------------------------------------|--------------|
| LSV48 SA085/SA066 7 in | KIT | 3780 4093 42 |
| | Includes 12 Flange set | 3780 2799 50 |
| | Optional 7 in diamond cutting disc | 3780 5074 62 |

ROUTER

Pattern fixture cutting of composite in the aerospace industry as well as trimming of composite materials is preferably done with a router. The LSK37 is the only router with dust extraction and support bearing integrated into one unit. This gives the LSK37 excellent performance and ergonomics in most composite applications.

- **Productive** – The speed governor maintains the rotational speed at applied feed-force which enables fast and effective cutting and prevents the bit from clogging.
- **Ergonomic** – An integrated dust extraction hood for deportation of hazardous dust, thermally insulated throttle handle, sound dampening exhaust valve and piped-away exhaust air provides the operator with the best working environment.



LSK38



LSK37

| Model | Free speed r/min | Collet size | Weight lb | Power hp | Air consumption cfm | Recommended hose size | | Hose fitting thread NPT | Ordering No. |
|----------------|---------------------|----------------|--------------|-------------|---------------------------|--------------------------|-----|----------------------------------|--------------|
| | | | | | | mm | in | | |
| LSK37 S250-DS1 | 25000 | 6 mm | 6.1 | 0.95 | 32 | 13 | 1/2 | 3/8 | 8423 1234 41 |
| LSK37 S250-DS2 | 25000 | 1/4 | 6.1 | 0.95 | 32 | 13 | 1/2 | 3/8 | 8423 1234 42 |
| LSK38 S250 Do | 25000 | 1/4 | 2.2 | 1.8 | 58 | 13 | 1/2 | 3/8 | 8423 0700 00 |
| LSK38 S180 Do | 18000 | 1/4 | 2.2 | 1.8 | 58 | 13 | 1/2 | 3/8 | 8423 0700 01 |

Suction requirement: 200 m³/h. **NOTE:** LSK38 delivered without rotor housing

Cutting operations in glass and carbon fiber as well as metal sheet, wood and steel can successfully be performed with a circular cutter.

- **Effective** – LCS10 and LCS38 cut to a depth of 10 and 26 mm respectively.
- LCS38 is suitable for diamond coated blades only.
- **Dust extraction** – Cutting of composite materials generates dust containing particles hazardous to health. The dust must be deposited in order to prevent the operator from inhaling it.

LCS38 is equipped with a cutter blade guard with integrated dust extraction hood for external vacuum source.

LCS38



LCS10



| Model | Free speed r/min | Max output hp | Max cutting depth in | Max cutter blade dia in | Weight lb | Air consumption at free speed cfm | Rec. hose size | | Air inlet thread | Ordering No. |
|--------------------------|---------------------|------------------|----------------------------|----------------------------------|--------------|---|-------------------|-----|------------------------|--------------|
| | | | | | | | mm | in | | |
| LCS10 | 3000 | 0.4 | 3/8 | 2 | 3.1 | 16 | 6.3 | 1/4 | BSP 1/4 | 8424 1161 38 |
| LCS38 S150D ^a | 15000 | 1.7 | 1 | 4 | 3.7 | 58 | 13.0 | 1/2 | BSP 3/8 | 8424 1125 06 |

^a Suction requirement: 200 m³/h.

Accessories Included

Flanges for diamond blade
Hose nipple for 13 mm air hose

Optional Accessories

CUTTER BLADES

| Model | Application | Max thickness of material in | No. of teeth | Dia in | Hole in | Ordering No. |
|-------|------------------------------|------------------------------------|-----------------|-----------|------------|--------------|
| | | | | | | |
| | Steel sheet (std) | 3/64 | 62 | 2 | 3/8 | 4190 0395 00 |
| | Aluminum | 3/32 | 34 | 2 | 3/8 | 4190 0396 00 |
| | Wood | 3/8 | 34 | 2 | 3/8 | 4190 0396 00 |
| LCS38 | Diamond disc for fibre glass | 3/4 | 44/60 (Grain) | 3 | 1/2 | 3780 5073 00 |
| | Diamond disc for fibre glass | 1 | 44/60 (Grain) | 4 | 1/2 | 3780 5074 00 |

SUCTION HOSE SET

| Model | Ordering No. |
|---|--------------|
| Suction hose set, (L= 5.9 in, Dia 1 1/4") for LCS38 | 3780 2724 31 |

Productivity Kits

| Model | Max air flow | Hose 16.4 ft | Coupling | Lubrication | Ordering No. |
|--------------------------------|--------------|--------------|--------------|-------------|--------------|
| MIDI Optimizer F/RD EQ10US-T13 | 65 cfm | Turbo 13 | ErgoQIC 10US | Yes | 8202 0850 29 |
| MIDI Optimizer F/R EQ10US-T13 | 65 cfm | Turbo 13 | ErgoQIC 10US | No | 8202 0850 30 |

NOTE: Tool nipple is not included in the Productivity kit and needs to be order separately together with the tool.

PERCUSSIVE TOOLS

A worker wearing a blue safety helmet with a clear face shield, a red long-sleeved shirt, and a dark leather apron is using a yellow and black percussive tool on a metal surface. The worker is wearing dark work gloves. The background shows a workshop environment with various tools and equipment.

Contents

| | |
|------------------------|-----|
| Introduction..... | 245 |
| Product safety..... | 246 |
| Chipping hammers | 247 |
| Scalers..... | 249 |
| Chisels..... | 251 |
| Riveting systems | 254 |
| Riveting hammers..... | 255 |
| Bucking bars..... | 257 |

These tools make light of the toughest jobs

Atlas Copco percussive tools are ideal for all material removal tasks in foundries, engineering workshops and shipyards. Built-in-ergonomic features such as vibration damping reduce the human load, delay fatigue and help protect the operator against the ill effects of long-term exposure to vibration and noise.

Our tools are made out of lightweight alloys to keep weight down while maintaining performance. This makes our tools extremely effective in the hands of your skilled operators.

WELD FLUX REMOVAL

Our tools are used when fettling welds from flux and spatter and in general scaling operations.

The conventional scaler RRC 13 and RRC 13B with a blowing function are the preferred models for these types of application. These tools have the right power and a sturdy reliable design. They also have a low vibration level for conventional models.

RUST AND PAINT REMOVAL

Rust and paint removal is a common application found in various types of industries such as shipbuilding, large transport sector and on offshore rigs.

Our RVM07B has low noise and is vibration damped. The standard chisel delivered with the tool is carbide tipped for a long service life. The tool is also equipped with a clean blowing device.

For lighter jobs the needle scaler RRC 13N is the ideal tool. Needle sets of different shapes and material are available to suit most operations.

CHIPPING AND SCALING

Percussive tools for chipping and scaling are widely used in all kinds of metalworking, construction and other industrial areas. Applications could be slag chipping, concrete trimming and sheet-metal cutting.

We offer high power-to-weight tools for these kind of applications. RRF 21/31 and RRD 37/57 models are vibration damped for operator comfort.

Our RRC22-RRC75 models are robust and highly dependable conventional chipping hammers suitable for heavy roughening.

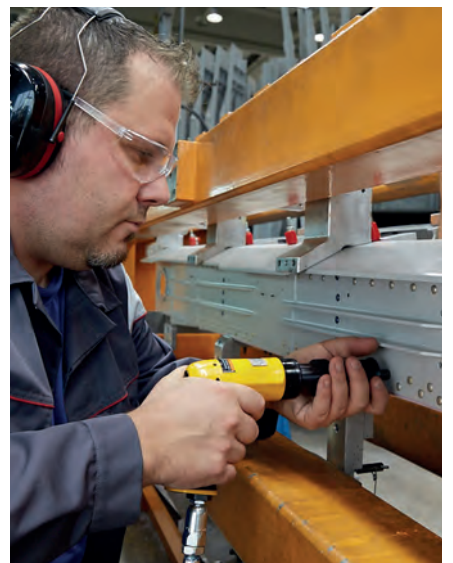

Product Safety

IMPORTANT: All local safety regulations with respect to installation, operation and overhaul must always be followed.

AVOID ACCIDENTS

- 1** The chisel, die or punch may fall out or may be shot out of the tool accidentally causing serious injury.



To prevent injury from a flying chisel:

- Always use a retainer.
- Inspect the retainer for wear or damage regularly.



- Be aware that the chisel may break during operation.
- Never trigger a hammer unless held against a work piece.
- Remove chisel, die or punch from tool when work is over.
- When finishing a job, disconnect the tool from its air supply.
- Before changing accessories, chisel or die – disconnect the tool from the air supply.

- 2** Chips and sparks should be prevented from striking an eye or another worker.



To prevent vision loss:

- Always wear eye protection.
- Isolate work of this kind by using barriers between work stations.
- Do not use the tool for other purposes than it is intended for.

- 3** Gloves protect fingers from pinching, scuffing and scraping.

- Protective shoes may prevent your feet from being injured.

- 4** Explosive atmosphere must not be ignited.



To prevent injury and property loss from fires:

- Use other technique.
- Use accessories of non sparking material (e.g. needle attachment of Beryllium copper for a needle scaler).

- 5** Electric shock may be fatal.

- Avoid chiseling into electric wiring hidden inside walls etc.

LONG TERM RISKS

- 6** Always use ear protection.



To prevent gradual loss of hearing due to exposure to high noise level – wear ear protection.

- 7** Vibration may be harmful to hands and arms.



- Use vibration dampened tools if available.
- Reduce the total time of exposure to vibrations, particularly if the operator has to guide the chisel by hand.

- 8** Dust generated during operation may be harmful.

- Use spot suction or a breathing apparatus.

PROPER USE AND MAINTENANCE

- 9** Do not perform idle blows with a hammer.



- They will cause high internal stresses and shorten the life of the tool.
- Note the risk of shooting out the chisel, die or punch if the retainer is not in order or damaged.

- 10** Quick coupling.

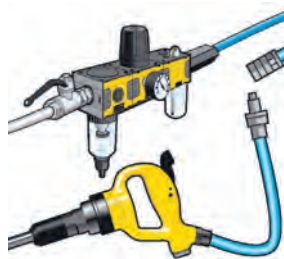

- If a coupling is used on a percussive tool, it should be separated from the tool by a whip hose (length 0.5 m).

- 11** Follow the tool manual and the lubrication instructions.

- 12** Perform overhauls at regular intervals.

- **RRF21/31** have a sturdy D-handle in light metal alloy for a high power-to-weight ratio and steady grip. The compact, vibration-controlled design offers good accessibility and ease of use.
- **RRD37/57** are light, quiet and have a long service life. They have light alloy tool casings, very low vibration and noise levels, vibration damping in both hand grips, and piped away exhaust.



| Model | Blows Hz | Piston dia | | Stroke | | Energy per blow | | Weight | | Bushing | | Air consumption | | Hose size | | Air inlet NPT | Ordering No. |
|----------|-------------|--------------------|---------|--------|-----|--------------------|-------|--------|-----|-------------------|------|--------------------|------|-----------|-----|----------------------|--------------|
| | | mm | in | mm | in | J | ft lb | kg | lb | mm | in | l/s | cfm | mm | in | | |
| RRF21-01 | 57 | 18 | 0.7 | 33 | 1.3 | 2.0 | 1.5 | 1.75 | 3.3 | 12.7 ^c | 0.50 | 6.5 | 13.8 | 10.0 | 3/8 | 3/8 | 8425 1104 05 |
| RRF31-01 | 38 | 22 | 0.9 | 43 | 1.7 | 4.4 | 3.2 | 2.5 | 5.3 | 12.7 ^c | 0.50 | 7.5 | 15.9 | 10.0 | 3/8 | 3/8 | 8425 1104 15 |
| RRF31-02 | 38 | 22 | 0.9 | 43 | 1.7 | 4.4 | 3.2 | 2.5 | 5.3 | 12.7 ^c | 0.50 | 7.5 | 15.9 | 10.0 | 3/8 | 3/8 | 8425 1104 16 |
| RRD37-11 | 35 | 27/19 ^a | 1.1/0.8 | 70 | 2.8 | 6.8 | 5.0 | 3.0 | 6.6 | 17.3 ^d | 0.68 | 7.2 | 15.3 | 12.5 | 1/2 | special ^e | 8425 1101 22 |
| RRD57-11 | 31 | 28/18 ^b | 1.1/0.8 | 92 | 3.6 | 9.3 | 6.9 | 3.4 | 7.5 | 17.3 ^d | 0.68 | 9.5 | 20.1 | 12.5 | 1/2 | special ^e | 8425 1103 20 |
| RRD57-12 | 31 | 28/18 ^b | 1.1/0.8 | 92 | 3.6 | 9.3 | 6.9 | 3.4 | 7.5 | 17.3 ^d | 0.68 | 9.5 | 20.1 | 12.5 | 1/2 | special ^e | 8425 1103 38 |

^a Effective piston dia 19 mm, 0.75 in.

^b Effective piston dia 21.5 mm, 0.85 in.

^c ISO.

^d Spline.

^e Integrated hose barb.

-01 and -11: Guided models,

-02 and -12: Non guided models.

Chipping Hammers

- **Dependable** – Their robust construction makes them highly dependable.
- **Efficient** – RRC65 and RRC75 have a blow rate which makes them particularly suitable for roughening.
- **Chisel retainer** – for safer jobs – RRC22-RRC75 are delivered with a chisel retainer as standard. For the same reason choose a tool that can be guided via the machine itself and not by holding the chisel.

Atlas Copco chipping hammers of series RRC are delivered with a standard, guided ISO hexagon nozzle (-01) or a round, non guided shank nozzle (-02).



| Model | Blows Hz | Piston dia | | Stroke | | Energy per blow | | Weight | | Bushing | | Air consumption | | Hose size | | Air inlet NPT | Ordering No. |
|-----------|-------------|------------|-----|--------|-----|--------------------|-------|--------|------|-------------------|------|--------------------|------|-----------|-----|----------------------|--------------|
| | | mm | in | mm | in | J | ft lb | kg | lb | mm | in | l/s | cfm | mm | in | | |
| RRC22F-01 | 62 | 15 | 0.6 | 52 | 2.0 | 2.7 | 2.0 | 2.2 | 4.9 | 12.7 ^a | 0.50 | 6.2 | 13.1 | 10 | 3/8 | 3/8 | 8425 0202 22 |
| RRC22F-02 | 62 | 15 | 0.6 | 52 | 2.0 | 2.7 | 2.0 | 2.2 | 4.9 | 12.7 ^a | 0.50 | 6.2 | 13.1 | 10 | 3/8 | 3/8 | 8425 0202 30 |
| RRC34B-01 | 45 | 24 | 0.9 | 67 | 2.6 | 5.5 | 4.1 | 4.5 | 9.9 | 17.3 ^a | 0.68 | 8.0 | 14.0 | 12.5 | 1/2 | special ^b | 8425 0212 53 |
| RRC65B-01 | 40 | 29 | 1.1 | 50 | 2.0 | 10.0 | 7.3 | 5.9 | 13.0 | 17.3 ^a | 0.68 | 10.8 | 22.9 | 12.5 | 1/2 | special ^b | 8425 0225 33 |
| RRC75B-01 | 30 | 29 | 1.1 | 75 | 3.0 | 16.0 | 11.8 | 6.5 | 14.3 | 17.3 ^a | 0.68 | 14.0 | 29.6 | 12.5 | 1/2 | special ^b | 8425 0225 58 |

^a ISO. ^b Integrated hose barb.

Dimensions (in)

| Model | L | H | D |
|-------|------|-----|-----|
| RRF21 | 9.7 | 6.3 | 1.3 |
| RRF31 | 10.4 | 6.7 | 1.4 |
| RRD37 | 16.5 | 6.9 | — |
| RRD57 | 18.0 | 7.5 | — |

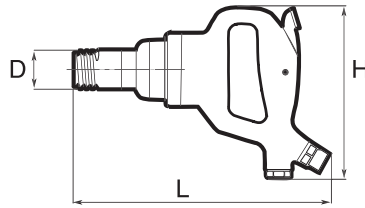

RRF21/31

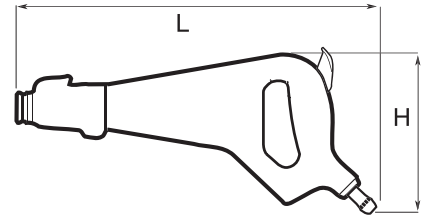

RRD37/57

| Model | L | H | D |
|-------|------|-----|-----|
| RRC22 | 10.2 | 6.1 | 1.3 |
| RRC34 | 13.0 | 6.3 | 1.7 |
| RRC65 | 13.2 | 6.7 | 2.1 |
| RRC75 | 15.4 | 6.7 | 2.1 |

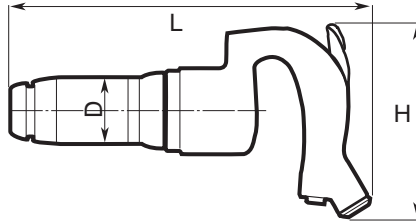

RRC

Accessories Included

RRF MODELS

Chisel retainer and a hose fitting

RRD MODELS

Flat chisel
Silencer complete
Hand grip
Key

RRC MODELS

Chisel retainer and hose fitting

Optional Accessories

| Model | Ordering No. |
|------------------------------|--------------|
| Power regulator | |
| RRF21 and -31 | 3512 0273 80 |
| Retainer, open type | |
| RRF21 | 3512 0290 90 |
| RRF31 | 3512 0305 90 |
| Protective handle kit | |
| RRF21 | 3512 0349 81 |
| RRF31 | 3512 0349 82 |

CHISELS

For a wide choice of chisels, see pages with "Chisels" at the end of this chapter.

Productivity Kits

| Model | Max air flow | Hose 16.4 ft | Coupling | Lubrication | Ordering No. |
|--------------------------------|--------------|--------------|--------------|-------------|--------------|
| MIDI Optimizer F/RD EQ10US-T13 | 65 cfm | Turbo 13 | ErgoQIC 10US | Yes | 8202 0850 29 |
| MIDI Optimizer F/R EQ10US-T13 | 65 cfm | Turbo 13 | ErgoQIC 10US | No | 8202 0850 30 |

NOTE: Tool nipple is not included in the Productivity kit and needs to be order separately together with the tool.

RVM07B is the obvious choice for task such as weld dressing light concrete trimming and for removal of paint and rust.

- **Vibration-damped with low-noise level.**
- **Two-job capacity** – RVM07B features a clean-blowing device which is very useful in order to keep the work piece clean from slag and other particles from the process.



RVM07B

| Model | Blows Hz | Weight incl. standard chisel | | Air consumption | | Hose size | | Air inlet NPT | Ordering No. |
|--------|-------------|------------------------------------|-----|--------------------|-----|-----------|-----|---------------------|--------------|
| | | kg | lb | l/s | cfm | mm | in | | |
| RVM07B | 100 | 1.7 | 3.8 | 3.8 | 8.1 | 6.3 | 1/4 | 1/4 | 8425 0105 25 |

Dimensions

| Model | L in | D in |
|--------|---------|---------|
| RVM07B | 10.7 | 1.5 |

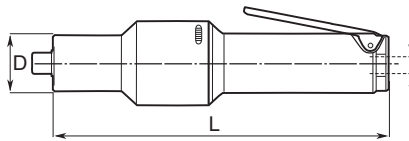

Choose between two different models for heavy slag chipping and for instant trimming of concrete.

- **High removal rate** – RRC13 is very effective and has a high removal rate in relation to its low weight.
- **Well proven** percussive mechanism and retainer.
- **Two-job capacity** – RRC13B with extra clean-blowing device.
- **Improved back head** – Throttle valve and lever with really Heavy Duty performance for long service life. Clean blowing system with twice the previous blow



RRC13B

capacity. Big blow button for easy operation and sturdy valve stem to resist rough handling.

| Model | Blows Hz | Piston dia | | Stroke | | Energy per blow | | Weight | | Air consumption | | Hose size | | Air inlet BSP | Ordering No. |
|--------|-------------|------------|-----|--------|-----|--------------------|-------|--------|-----|--------------------|-----|-----------|-----|------------------|--------------|
| | | mm | in | mm | in | J | ft lb | kg | lb | l/s | cfm | mm | in | | |
| RRC13 | 73 | 15 | 0.6 | 35 | 1.4 | 1.4 | 1.0 | 1.4 | 3.1 | 4.0 | 8.0 | 10 | 3/8 | 3/8 | 8425 0101 30 |
| RRC13B | 73 | 15 | 0.6 | 35 | 1.4 | 1.4 | 1.0 | 1.6 | 3.5 | 4.0 | 8.0 | 10 | 3/8 | 3/8 | 8425 0101 33 |

B = Blow Gun

Dimensions

| Model | L in | H in | D ₁ in | D ₂ in |
|--------|---------|---------|----------------------|----------------------|
| RRC13 | 8.7 | 2.6 | 1.8 | 1.6 |
| RRC13B | 9.1 | 2.6 | 1.8 | 1.6 |

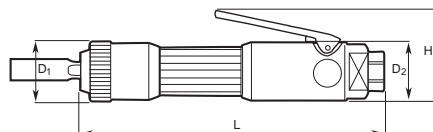

Needle Scaler

The effective needle scaler, type RRC13N, is based on the same fundamental design as the straight chipping hammers of type RRC13 described above.

- **Sturdy design** – Easy to maintain.
- **Versatile** – The needle scaler is used to remove welding slag, rust and paint from steel structures.



RRC13N

| Model | Blows Hz | Piston dia | | Stroke | | Energy per blow | | Weight | | Air consumption | | Hose size | | Air inlet NPT | Ordering No. |
|--------|-------------|------------|-----|--------|-----|--------------------|-------|--------|-----|--------------------|-----|-----------|-----|------------------|--------------|
| | | mm | in | mm | in | J | ft lb | kg | lb | l/s | cfm | mm | in | | |
| RRC13N | 73 | 15 | 0.6 | 35 | 1.4 | 1.4 | 1.0 | 1.9 | 4.2 | 4.0 | 8.0 | 10 | 3/8 | 3/8 | 8425 0101 36 |

Dimensions

| Model | L ₁ in | L ₂ in | D in |
|--------|----------------------|----------------------|---------|
| RRC13N | 11.1 | 13.9 | 1.5 |

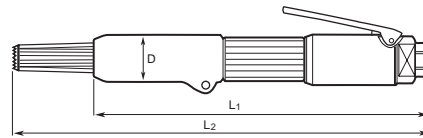

Accessories Included

FOR ALL RRC13

Hose fitting
Scaling chisel

FOR RMV07B

Hose fitting
Flat carbide tipped chisel 10x120 mm

Optional Accessories

FOR RRC13, 13B

| RRC13 / RRC13B | Ordering No. |
|----------------|--------------|
| Hand guard | 3510 0246 90 |
| Silencer | 3510 0366 80 |

Chisels for RRC13 and -13B:
Square shank 13.0 mm

FOR RRC13N

NEEDLE-SET OF 19 NEEDLES, LENGTH 100 MM

| Material | Ordering No. |
|---|--------------|
| Steel, standard | 3510 0221 90 |
| Steel flat ends | 3510 0227 90 |
| Stainless steel flat ends | 3510 0228 90 |
| Beryllium copper flat ends (spark resistant) | 3510 0229 90 |

FOR RMV07B

Carbide tipped chisels and through hardened chisels with other length and width, see separate page for chisels.







Productivity Kits

| Model | Max air flow | Hose 16.4 ft | Coupling | Lubrication | Ordering No. |
|--------------------------------|--------------|--------------|--------------|-------------|--------------|
| MIDI Optimizer F/RD EQ10US-T13 | 65 cfm | Turbo 13 | ErgoQIC 10US | Yes | 8202 0850 29 |
| MIDI Optimizer F/R EQ10US-T13 | 65 cfm | Turbo 13 | ErgoQIC 10US | No | 8202 0850 30 |

NOTE: Tool nipple is not included in the Productivity kit and needs to be order separately together with the tool.

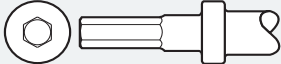
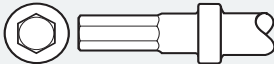

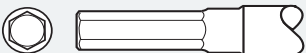
Chisels for Chipping hammers. All chisels are normally through hardened. Otherwise, see tables.

| Figure | Shank type | Tools | Table |
|---|---|--------------------------------------|-------|
|  | Square shank 13.0 mm | RRC13, RRC13B | 1 |
|  | Extended square shank ISO, 12.7 mm | | 1 |
|  | Hexagon and round shank ISO, round collar 12.7 mm | RRC22F-01, RRC22F-02 RRF21, RRF31 | 2 |
|  | Hexagon shank ISO round collar 17.3 mm | RRC34B-01, RRC65B-01, RRC75B-01 | 3 |
|  | Round shank ISO, with splines 17.3 mm | RRD37, RRD57 | 3 |
|  | Hexagon shank ISO without round collar 17.3 mm | RRC34-01, RRC65-01, RRC75-01 | 4 |
|  | Round shank ISO, without collar 17.3 mm | RRC34-02, RRC65-02, RRC75-02 | 4 |
|  | Special shank | RVM07B | 5 |

Chisels

- 1 A. Chisels with square shank 1/2"
 B. Chisels with square shank ISO 1/2"
 C. Square shank 1/2" in round end. For RRC13B

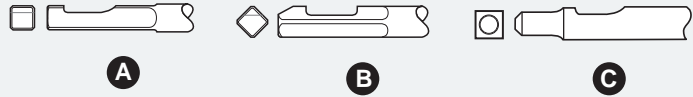

| Chisel type | Designation | Width | | Length | | Square 1/2" Ordering No. | ISO Extended square 1/2" Ordering No. | Ordering No. |
|-------------|----------------------|-------|------|--------|------|--------------------------|---------------------------------------|--------------|
| | | mm | in | mm | in | | | |
| | Chisel blank | 15 | 0.59 | 155 | 6.1 | 3085 0020 00 | | |
| | | 15 | 0.59 | 200 | 7.9 | 3085 0020 01 | | |
| | | 15 | 0.59 | 300 | 11.8 | 3085 0020 02 | | |
| | Flat chisel | 15 | 0.59 | 165 | 6.1 | 3085 0227 00 | 3085 0230 01 | |
| | | 15 | 0.59 | 200 | 7.9 | 3085 0227 01 | | |
| | | 15 | 0.59 | 110 | 4.3 | | | 3512 0114 00 |
| | | 15 | 0.59 | 185 | 7.3 | | | 3512 0070 00 |
| | Wide flat chisel | 35 | 1.38 | 165 | 6.5 | 3085 0032 00 | 3085 0232 01 | |
| | | 35 | 1.38 | 200 | 7.9 | 3085 0032 01 | | |
| | | 35 | 1.38 | 300 | 11.8 | 3085 0032 02 | | |
| | | 55 | 2.17 | 165 | 6.5 | 3085 0332 00 | | |
| | | 35 | 1.4 | 178 | 7 | | | 3512 0115 00 |
| | Angle scraper chisel | 35 | 1.38 | 165 | 6.5 | 3085 0176 00 | 3085 0362 00 | |
| | | 35 | 1.38 | 200 | 7.9 | 3085 0176 01 | | |
| | | 55 | 2.17 | 165 | 6.5 | 3085 0333 00 | | |
| | Scaling chisel | 15 | 0.59 | 155 | 6.1 | 3085 0018 00 | 3085 0229 01 | |
| | | 15 | 0.59 | 200 | 7.9 | 3085 0018 02 | | |
| | | 15 | 0.59 | 300 | 11.8 | 3085 0018 01 | | |

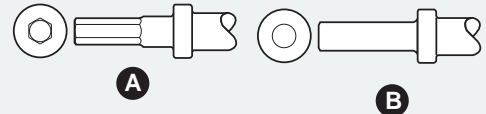

- 2 A. Chisels with hexagon shank ISO, round collar 1/2 in.
 For RRC22F-01.
 B. Chisels with round shank ISO, round collar 1/2 in.
 For RRC22F-02.



| Chisel type | Designation | Width | | Length | | Hex ISO 12.7 mm (1/2") Ordering No. | Round ISO 12.7 mm (1/2") Ordering No. |
|-------------|----------------------|-------|------|--------|------|-------------------------------------|---------------------------------------|
| | | mm | in | mm | in | | |
| | Chisel blank | 13 | 0.51 | 200 | 7.9 | 3085 0182 00 | |
| | | 13 | 0.51 | 350 | 13.8 | 3085 0182 01 | |
| | | 13 | 0.51 | 400 | 15.7 | 3085 0182 04 | |
| | | 13 | 0.51 | 500 | 19.7 | 3085 0182 05 | |
| | Flat chisel | 13 | 0.51 | 200 | 7.9 | 3085 0183 00 | 3085 0184 00 |
| | | 35 | 1.38 | 300 | 11.8 | 3085 0376 00 | |
| | Sharp chisel | 15 | 0.59 | 200 | 7.9 | 3085 0170 00 | |
| | | 15 | 0.59 | 300 | 11.8 | 3085 0170 01 | |
| | Spot weld chisel | 17 | 0.69 | 200 | 7.9 | 3085 0301 00 | |
| | Angle scraper chisel | 30 | 1.18 | 200 | 7.9 | 3085 0262 00 | |
| | Pipe cutting chisel | 20 | 0.78 | 200 | 7.9 | 3085 0302 00 | |
| | | 35 | 1.38 | 200 | 7.9 | 3085 0303 00 | |
| | Plate cutting chisel | 14.5 | 0.57 | 200 | 7.9 | 3085 0263 00 | |
| | Plate cutting chisel | 16 | 0.62 | 200 | 7.9 | 3085 0173 00 | |
| | Moil point chisel | 13 | 0.51 | 200 | 7.9 | 3085 0297 00 | |
| | | 13 | 0.51 | 305 | 12.0 | 3085 0297 01 | |

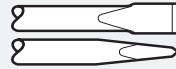
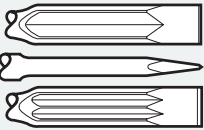
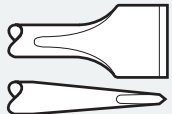

3 Chisels with round ISO shank with splines 0.68 in. For RRD 37-11, RRD 37-12, RRD 57-11, RRD 57-12.



| Chisel type | Designation | Width | | Length | | Round ISO with splines 17.3 mm (0.68") Ordering No. |
|---|------------------------|-------|------|--------|------|---|
| | | mm | in | mm | in | |
|  | Chisel blank | 22 | 0.86 | 250 | 9.8 | 3085 0242 00 |
| | | 22 | 0.86 | 340 | 13.4 | 3085 0242 01 |
| | | 22 | 0.86 | 550 | 21.7 | 3085 0242 02 |
| | | 22 | 0.86 | 800 | 31.5 | 3085 0242 03 |
|  | Flat chisel | 22 | 0.86 | 215 | 8.5 | 3085 0236 00 |
| | | 22 | 0.86 | 250 | 9.8 | 3085 0236 01 |
| | | 22 | 0.86 | 340 | 13.4 | 3085 0236 02 |
| | | 22 | 0.86 | 550 | 21.7 | 3085 0236 03 |
|  | Flat chisel | 32 | 1.26 | 340 | 13.4 | 3085 0252 00 |
| | | | | | | |
| | | | | | | |
|  | Wide flat chisel | 50 | 1.97 | 340 | 13.4 | 3085 0250 00 |
| | Extra wide flat chisel | 130 | 5.12 | 400 | 15.7 | 3085 0998 00 |
|  | Angle scraper chisel | 50 | 1.97 | 335 | 13.2 | 3085 0350 00 |
| | | | | | | |
|  | Moil point chisel | 22 | 0.86 | 340 | 13.4 | 3085 0249 00 |

4 Chisels with special shank. For RVM07.

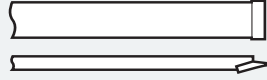

| Chisel type | Designation | Material | Width | | Length | | Ordering No. |
|---|-------------|------------------------|-------|------|--------|------|--------------|
| | | | mm | in | mm | in | |
|  | Flat chisel | Tungsten carbide | 10 | 0.39 | 120 | 4.7 | 3085 0321 00 |
| | | Through hardened steel | 10 | 0.39 | 120 | 4.7 | 3085 0325 00 |
| | | Tungsten carbide | 10 | 0.39 | 200 | 7.9 | 3085 0321 01 |
| | | Tungsten carbide | 10 | 0.39 | 300 | 11.8 | 3085 0321 02 |
| | | Tungsten carbide | 20 | 0.79 | 120 | 4.7 | 3085 0345 00 |
| | | Through hardened steel | 20 | 0.79 | 120 | 4.9 | 3085 0346 00 |
|  | Wide chisel | Tungsten carbide | 35 | 1.38 | 120 | 4.7 | 3085 0322 00 |
| | | Through hardened steel | 35 | 1.38 | 120 | 4.7 | 3085 0327 00 |

Minimum vibration, maximum productivity

Atlas Copco's top-of-the-line riveting systems are designed to minimize the riveter's exposure to vibration, while maintaining high tool performance. The RRH recoilless riveting hammer has an air cushion behind the hammer piston which efficiently kills vibrations. The same air dampening technique is used in RBB bucking bars. It raises individual productivity and boosts output in your plant.

The Atlas Copco riveting system includes vibration-damped hammers RRH and bucking bars RBB – as well as conventional riveting hammers RRN.

The vibration-damped riveting hammers – RRH – are available in different sizes.

Each size is available in “Trigger start” and “Push to start” models.

The conventional riveting hammer – RRN – is available in one size: RRN11P.

CRITICAL FACTORS

The number of blows and the power are critical factors which determine the strength of a riveted joint. A few powerful blows are needed to fill out the hole and form a head when upsetting the rivet. The impact force is critical to some extent when working with aluminum alloys, as too many blows can embrittle the metal.

In terms of capacity, the tools overlap. The selection guide below helps you to find the right tool for your particular application of riveting.

The vibration-damped bucking bars RBB are available in two versions – the simple spring damped – SP type and the air servo assisted SA type.



Selection Guide

| Hammer model ^a | Nominal Max. Rivet Diameter Capacity | | | | | | | Bucking bar model required ^b |
|---------------------------|--------------------------------------|-------------|-------|-------------|----------|-------------|--|---|
| | Dural | | Steel | | Titanium | | | |
| | mm | in | mm | in | mm | in | | |
| RRN11 | 2-5 | 3/32 - 3/16 | 1-4 | 3/32 - 5/32 | | | | |
| RRH04 | 2-5 | 3/32 - 3/16 | 1-4 | 3/21 - 5/32 | | | | RBB04 |
| RRH06 | 4-7 | 5/32 - 1/4 | 3-6 | 1/8 - 1/4 | 2-4 | 3/32 - 5/32 | | |
| RRH08 | 5-8 | 3/16 - 5/16 | 4-7 | 5/32 - 1/4 | 3-6 | 1/8 - 1/4 | | |
| RRH10 | 5-9 | 3/16 - 3/8 | 6-8 | 1/4 - 5/16 | 4-7 | 5/32 - 1/4 | | |
| RRH12 | 8-11 | 5/16 - 7/16 | 7-10 | 1/4 - 3/8 | 6-9 | 1/4 - 1/8 | | |
| RRH14 | 11-13 | 7/16 - 1/2 | 9-12 | 3/8 - 15/32 | 8-11 | 5/16 - 7/16 | | |

^a Hammer capacity depends on direct/indirect riveting as well as Panel density and stiffness.

^b Bucking bar capacity is dependent on dolly weight.

Vibration-damped

Riveting Hammers

RRH is a unique series of riveting hammers incorporating completely revolutionary ergonomic advantages.

- **Versatile** – RRH can easily cope with rivets in diameters up to 13 mm.
- **Vibration-damped system** – The RRH vibration-damped riveting hammer, combined with the RBB vibration-damped bucking bar, offer an unbeatable system for riveting.
- **Adjustable power.**
- **Adjustable hand guard** – Support hand grip is vibration-damped.
- Models with trigger start for excellent handling. Pistol grip with rubber coating.



| Model | Blows Hz | Nozzle | | Piston dia | | Stroke | | Energy per blow | | Weight | | Air consumption | | Hose size | | Air inlet NPT | Ordering No. |
|---------------------------|-------------|--------|-----|------------|-----|--------|-----|--------------------|-------|--------|-----|--------------------|-----|-----------|-----|------------------|--------------|
| | | mm | in | mm | in | mm | in | J | ft lb | kg | lb | l/s | cfm | mm | in | | |
| With push start | | | | | | | | | | | | | | | | | |
| RRH04P-01 | 66 | 10.0 | 0.4 | 15 | 0.6 | 40 | 1.6 | 2.0 | 1.5 | 1.0 | 2.2 | 3.7 | 6 | 6.3 | 1/4 | 1/4 | 8426 1111 07 |
| RRH04P-02 | 66 | 10.2 | 0.4 | 15 | 0.6 | 40 | 1.6 | 2.0 | 1.5 | 1.0 | 2.2 | 3.7 | 6 | 6.3 | 1/4 | 1/4 | 8426 1111 15 |
| RRH04P-12 | 66 | 10.2 | 0.4 | 15 | 0.6 | 40 | 1.6 | 2.0 | 1.5 | 1.0 | 2.2 | 3.7 | 6 | 6.3 | 1/4 | 1/4 | 8426 1111 25 |
| RRH06P | 36 | 10.2 | 0.4 | 15 | 0.6 | 102 | 4.0 | 6.0 | 4.4 | 1.3 | 2.9 | 9.0 | 19 | 10.0 | 3/8 | 1/4 | 8426 1111 04 |
| RRH08P | 24 | 10.2 | 0.4 | 15 | 0.6 | 137 | 5.4 | 8.0 | 5.9 | 1.4 | 3.0 | 10.0 | 21 | 10.0 | 3/8 | 1/4 | 8426 1111 09 |
| RRH10P | 25 | 12.7 | 0.5 | 19 | 0.7 | 118 | 4.6 | 13.0 | 9.6 | 2.0 | 4.4 | 12.0 | 24 | 10.0 | 3/8 | 1/4 | 8426 1110 20 |
| RRH12P | 20 | 12.7 | 0.5 | 19 | 0.7 | 153 | 6.0 | 16.0 | 11.8 | 2.1 | 4.6 | 13.0 | 28 | 10.0 | 3/8 | 1/4 | 8426 1110 47 |
| RRH14P | 18 | 12.7 | 0.5 | 19 | 0.7 | 188 | 7.4 | 19.5 | 14.4 | 2.2 | 4.8 | 13.0 | 28 | 10.0 | 3/8 | 1/4 | 8426 1110 80 |
| With trigger start | | | | | | | | | | | | | | | | | |
| RRH04P TS-12 | 66 | 10.2 | 0.4 | 15 | 0.6 | 40 | 1.6 | 2.0 | 1.5 | 1.0 | 2.2 | 3.7 | 6 | 6.3 | 1/4 | 1/4 | 8426 1111 27 |
| RRH06P TS | 36 | 10.2 | 0.4 | 15 | 0.6 | 102 | 4.0 | 6.0 | 4.4 | 1.3 | 2.9 | 9.0 | 19 | 10.0 | 3/8 | 1/4 | 8426 1111 66 |
| RRH08P TS | 24 | 10.2 | 0.4 | 15 | 0.6 | 137 | 5.4 | 8.0 | 5.9 | 1.4 | 3.0 | 10.0 | 21 | 10.0 | 3/8 | 1/4 | 8426 1111 68 |
| RRH10P TS | 25 | 12.7 | 0.5 | 19 | 0.7 | 118 | 4.6 | 13.0 | 9.6 | 2.0 | 4.4 | 12.0 | 24 | 10.0 | 3/8 | 1/4 | 8426 1110 70 |
| RRH12P TS | 20 | 12.7 | 0.5 | 19 | 0.7 | 153 | 6.0 | 16.0 | 11.8 | 2.1 | 4.6 | 13.0 | 28 | 10.0 | 3/8 | 1/4 | 8426 1110 72 |
| RRH14P TS | 18 | 12.7 | 0.5 | 19 | 0.7 | 188 | 7.4 | 19.5 | 14.4 | 2.2 | 4.8 | 13.0 | 28 | 10.0 | 3/8 | 1/4 | 8426 1110 81 |
| RRH12P-ENG | 20 | 12.7 | 0.5 | 19 | 0.7 | 153 | 6.0 | 16.0 | 11.8 | 2.1 | 4.6 | 13.0 | 28 | 10.0 | 3/8 | 1/4 | 8426 1110 49 |
| RRH14P-ENG | 18 | 12.7 | 0.5 | 19 | 0.7 | 188 | 7.4 | 19.5 | 14.4 | 2.2 | 4.8 | 13.0 | 28 | 10.0 | 3/8 | 1/4 | 8426 1110 82 |

-01 means 10 mm short shank rivet set.

-02 means 10.2 mm short shank rivet set.

-12 means 10.2 mm stand shank rivet set.

Conventional Type

Riveting Hammers

For riveting in confined spaces we recommend our RRN11 riveting hammer.

- **RRN11** – is the smallest riveting hammer available on the market, with unique accessibility.
- **Adjustable** – The RRN11 has a built-in adjustment knob with which you can set the power for different rivet materials and sizes.
- **Controllable** – The trigger is easily operated and provides excellent control.



| Model | Blows Hz | Nozzle | | Piston dia | | Stroke | | Energy per blow | | Weight | | Air consumption | | Hose size | | Air inlet NPT | Ordering No. |
|-----------|-------------|--------|-----|------------|-----|--------|-----|--------------------|-------|--------|-----|--------------------|-----|-----------|-----|------------------|--------------|
| | | mm | in | mm | in | mm | in | J | ft lb | kg | lb | l/s | cfm | mm | in | | |
| RRN11P-01 | 66 | 10.0 | 0.4 | 15 | 0.6 | 40 | 1.6 | 2.0 | 1.5 | 1.2 | 2.6 | 3.4 | 7.2 | 6.3 | 1/4 | 1/8 | 8426 1101 05 |
| RRN11P-02 | 66 | 10.2 | 0.4 | 15 | 0.6 | 40 | 1.6 | 2.0 | 1.5 | 1.2 | 2.6 | 3.4 | 7.2 | 6.3 | 1/4 | 1/8 | 8426 1101 13 |

-01 means 10 mm short shank rivet set.

-02 means 10.2 mm short shank rivet set.

Dimensions (in)

| Model | L in | H in | C in |
|------------|---------|---------|---------|
| RRH | | | |
| RRH04-01 | 6.3 | 5.8 | 0.9 |
| RRH04-02 | 6.3 | 5.8 | 0.9 |
| RRH04-12 | 6.9 | 5.8 | 0.9 |
| RRH06 | 8.9 | 5.8 | 0.94 |
| RRH08P | 9.6 | 5.8 | 0.94 |
| RRH10P | 10.4 | 5.9 | 1.06 |
| RRH12P | 11.8 | 5.9 | 1.06 |
| RRH14P | 13.1 | 5.9 | 1.06 |
| RRN | | | |
| RRN11P | 3.9 | 6.7 | 0.9 |

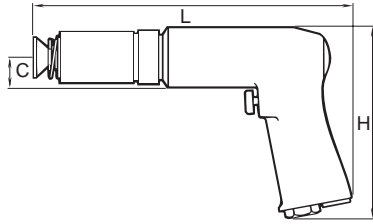

RRH

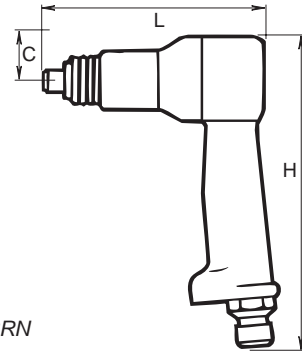

RRN

Accessories Included

For RRH models

- Hose fitting
- Flush set
- Open spring retainer

For RRN11P

- Hose fitting and retainer
- Blank rivet set
- Retainers for blank and flush rivet set

Optional Accessories

RIVET SETS. RRH AND RRN

| Hammer type | Model | Shank mm | Flush set | Ordering No. | Blank rivet set | Ordering No. |
|-------------------------------|-------|-------------|-----------|--------------|-----------------|-------------------------------|
| RRH04P-01 RRN11P-01 | (-01) | 10.0 spec | | 3085 0347 00 | | 3006 0983 00 |
| RRH04P-02 RRN11P-02 | (-02) | 10.2 spec | | 3085 0352 00 | | 3085 0353 00 |
| RRH04P-12 RRH06P RRH08P | (-12) | 10.2 std | | 3085 0324 00 | | 3085 0022 00 |
| RRH10P RRH12P RRH14P | | 12.7 std | | 3085 0323 00 | | 3085 0021 00 |
| RRH04P-12 RRH06P RRH08P | | 10.2 std | | | | 3085 0212 00 Mandrel blank |
| RRH04P-12 RRH06P RRH08P | | 10.2 std | | | | 3085 0212 02 |

An efficient riveting system consists of vibration-damped bucking bars together with vibration-damped riveting hammers.

- **Cramped spaces** – Mini bucking bars RBB04SP are ideal for work in confined spaces. The large mass types -04, -05 will in most applications set the rivet faster than the smaller models.



| Model | Weight | | Diameter | | Ordering No. |
|--------------------------|--------|-----|----------|-----|--------------|
| | kg | lb | mm | in | |
| Mini bucking bars | | | | | |
| RBB04SP-01 | 0.8 | 1.8 | 46 | 1.8 | 8426 9101 10 |
| RBB04SP-04 | 1.3 | 2.9 | 46 | 1.8 | 8426 9101 13 |
| RBB04SP-05 | 1.4 | 3.1 | 46 | 1.8 | 8426 9101 14 |
| RBB04SP-06 | 1.1 | 2.5 | 46 | 1.8 | 8426 9101 15 |

Dimensions (mm)

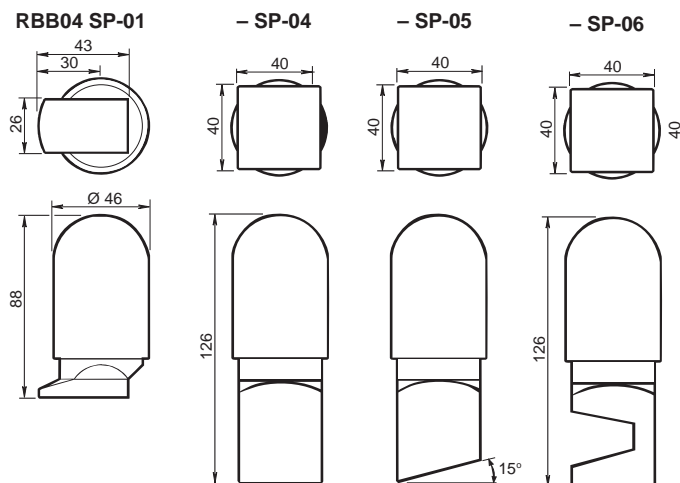

DRILLS



Contents

| | |
|---------------------------|-----|
| Introduction..... | 259 |
| Pistol grip drills | 261 |
| Straight drills..... | 265 |
| Angle drills..... | 267 |
| Modular drills | 271 |
| Micro stop drills..... | 274 |
| Tappers..... | 276 |
| Screw-feed drills..... | 278 |
| Positive feed drills..... | 279 |

Reliable, productive and comfortable to work with



The handheld drills in Atlas Copco's wide range are of the highest quality and built to provide consistent reliability and performance in a wide range of applications. Their advanced ergonomic designs make your job easier, safer and more efficient.

From the time our first drill was produced in 1901, Atlas Copco has demonstrated a genuine understanding of customer needs. Our drills have evolved to meet changing customer demands over the years. Whatever the job, Atlas Copco has a drill to match your exact requirements.

RELIABLE

When you pick up an Atlas Copco drill, you can be confident that it will do the job over and over again.

POWERFULLY PRODUCTIVE

Despite their compact designs, our drills consistently deliver all the power you need. Their high power-to-weight ratio ensures maximum material removal in the shortest possible time.

ERGONOMIC

Thanks to 50 years of focusing on ergonomics, Atlas Copco drills fit comfortably in your hand. Grips are anatomically shaped to keep your arm and wrist straight, reducing the risk of injury during

long-term use. The light weight and perfect balance of each drill enables you to guide it smoothly and easily. Low noise and vibration levels make the tools comfortable to work with all day long.

DURABLE, LOW MAINTENANCE

The rugged, lubrication-free designs of our drills can withstand the toughest industrial situations and go on working day in, day out. Maintenance requirements are low.

QUALITY THROUGHOUT THE TOOLS' LIFE-CYCLE

Atlas Copco stands for quality, from the manufacture of critical drill components, through production and sales, to service and support throughout the tools' long life-cycle.



Regardless of which model you choose, you'll get a product with superior ergonomics and productivity.

- Quiet – Very low noise level.
- Comfortable grip – For high precision.
- Two-hand grip available – Gives even greater flexibility.
- Lubrication-free – For clean working environment and operator comfort.



| Model | Free speed r/min | Chuck capacity in | Weight with chuck lb | Air consumption at free speed cfm | Hose size | | Air inlet thread NPT | Power hp | Stall torque Nm | With chuck Ordering No. | Without chuck | |
|---|------------------|-------------------|----------------------|-----------------------------------|-----------|-----|----------------------|----------|-----------------|-------------------------|---------------|--------------|
| | | | | | mm | in | | | | | Model | Ordering No. |
| Non-reversible drills with air supply through handle | | | | | | | | | | | | |
| LBB16 EP-003 ^b | 300 | 3/8 | 1.5 | 17.0 | 6.3 | 1/4 | 1/4 | 0.4 | - | 8421 0108 01 | 003-U | 8421 0108 02 |
| LBB16 EP-005 ^b | 500 | 3/8 | 1.5 | 17.0 | 6.3 | 1/4 | 1/4 | 0.4 | 21.6 | 8421 0108 06 | 005-U | 8421 0108 07 |
| LBB16 EP-010 | 1000 | 3/8 | 1.5 | 17.0 | 6.3 | 1/4 | 1/4 | 0.4 | 7.8 | 8421 0108 10 | 010-U | 8421 0108 11 |
| LBB16 EP-024 ^a | 2400 | 1/4 | 1.2 | 17.0 | 6.3 | 1/4 | 1/4 | 0.4 | 4.2 | 8421 0108 20 | 024-U | 8421 0108 21 |
| LBB16 EP-033 ^a | 3300 | 1/4 | 1.2 | 17.0 | 6.3 | 1/4 | 1/4 | 0.4 | 3.4 | 8421 0108 30 | 033-U | 8421 0108 31 |
| LBB16 EP-045 ^a | 4500 | 1/4 | 1.2 | 17.0 | 6.3 | 1/4 | 1/4 | 0.4 | 2.0 | 8421 0108 40 | 045-U | 8421 0108 41 |
| LBB16 EP-060 ^a | 6000 | 1/4 | 1.2 | 17.0 | 6.3 | 1/4 | 1/4 | 0.4 | 1.7 | 8421 0108 50 | 060-U | 8421 0108 51 |
| LBB16 EP-200 ^a | 20000 | 1/4 | 1.2 | 17.0 | 6.3 | 1/4 | 1/4 | 0.4 | 0.5 | 8421 0108 60 | 200-U | - |
| LBB16 EPX-005 ^b | 500 | 1/2 | 1.5 | 20.0 | 6.3 | 1/4 | 1/4 | 0.45 | 25.2 | 8421 0108 08 | 005-U | 8421 0108 09 |
| LBB16 EPX-010 ^b | 1000 | 3/8 | 1.5 | 20.0 | 6.3 | 1/4 | 1/4 | 0.45 | 12.3 | 8421 0108 12 | 010-U | 8421 0108 03 |
| LBB16 EPX-024 ^a | 2400 | 1/4 | 1.2 | 20.0 | 6.3 | 1/4 | 1/4 | 0.45 | 4.9 | 8421 0108 22 | 024-U | 8421 0108 23 |
| LBB16 EPX-033 ^a | 3300 | 1/4 | 1.2 | 20.0 | 6.3 | 1/4 | 1/4 | 0.45 | 3.7 | 8421 0108 32 | 033-U | 8421 0108 33 |
| LBB16 EPX-045 ^a | 4500 | 1/4 | 1.2 | 20.0 | 6.3 | 1/4 | 1/4 | 0.45 | 3.0 | 8421 0108 42 | 045-U | 8421 0108 43 |
| LBB16 EPX-060 ^a | 6000 | 1/4 | 1.2 | 20.0 | 6.3 | 1/4 | 1/4 | 0.45 | 2.3 | 8421 0108 52 | 060-U | 8421 0108 53 |
| LBB16 EPX-200 ^a | 20000 | 1/4 | 1.2 | 20.0 | 6.3 | 1/4 | 1/4 | 0.45 | 0.6 | 8421 0108 82 | 200-U | 8421 0108 63 |
| LBB26 EPX-003 ^b | 300 | 1/2 | 1.8 | 31.8 | 10.0 | 3/8 | 1/4 | 0.7 | 53.5 | 8421 0500 00 | 003-U | 8421 0500 01 |
| LBB26 EPX-005 ^b | 500 | 1/2 | 1.8 | 31.8 | 10.0 | 3/8 | 1/4 | 0.7 | 31.6 | 8421 0500 02 | 005-U | 8421 0500 03 |
| LBB26 EPX-007 ^b | 700 | 1/2 | 1.8 | 31.8 | 10.0 | 3/8 | 1/4 | 0.7 | 24.6 | 8421 0500 04 | 007-U | 8421 0500 05 |
| LBB26 EPX-013 ^{ab} | 1300 | 3/8 | 1.7 | 31.8 | 10.0 | 3/8 | 1/4 | 0.7 | 14.7 | 8421 0500 06 | 013-U | 8421 0500 07 |
| LBB26 EPX-019 ^a | 1900 | 3/8 | 1.7 | 31.8 | 10.0 | 3/8 | 1/4 | 0.7 | 9.9 | 8421 0500 24 | 019-U | 8421 0500 25 |
| LBB26 EPX-026 ^a | 2600 | 5/16 | 1.7 | 31.8 | 10.0 | 3/8 | 1/4 | 0.7 | 7.7 | 8421 0500 08 | 026-U | 8421 0500 09 |
| LBB26 EPX-033 ^a | 3300 | 5/16 | 1.5 | 31.8 | 10.0 | 3/8 | 1/4 | 0.7 | 5.7 | 8421 0500 10 | 033-U | 8421 0500 11 |
| LBB26 EPX-045 ^a | 4500 | 5/16 | 1.5 | 31.8 | 10.0 | 3/8 | 1/4 | 0.7 | 4.1 | 8421 0500 12 | 045-U | 8421 0500 13 |
| LBB26 EPX-060 ^a | 6000 | 5/16 | 1.5 | 31.8 | 10.0 | 3/8 | 1/4 | 0.7 | 3.3 | 8421 0500 14 | 060-U | 8421 0500 15 |
| LBB26 EPX-200 ^a | 22000 | 1/4 | 1.5 | 31.8 | 10.0 | 3/8 | 1/4 | 0.7 | 0.8 | 8421 0500 28 | 200-U | 8421 0500 29 |
| LBB36 H005 ^b | 500 | - | 3.3 | 34.9 | 10.0 | 3/8 | 3/8 | 0.9 | 43.8 | - | -H005U | 8421 0408 03 |
| LBB36 H007 ^b | 700 | 1/2 | 3.5 | 34.9 | 10.0 | 3/8 | 3/8 | 0.9 | 37.2 | 8421 0408 07 | -H007U | 8421 0408 05 |
| LBB36 H013 ^a | 1300 | 3/8 | 3.3 | 34.9 | 10.0 | 3/8 | 3/8 | 0.9 | 19.5 | 8421 0408 15 | -H013U | 8421 0408 13 |
| LBB36 H026 ^a | 2600 | 3/8 | 2.5 | 34.9 | 10.0 | 3/8 | 3/8 | 0.9 | 10.3 | 8421 0408 33 | -H026U | 8421 0408 31 |
| LBB36 H033 ^a | 3300 | 3/8 | 2.5 | 34.9 | 10.0 | 3/8 | 3/8 | 0.9 | 8.6 | 8421 0408 41 | -H033U | 8421 0408 39 |
| LBB36 H060 ^a | 6000 | 1/4 | 2.5 | 34.9 | 10.0 | 3/8 | 3/8 | 0.9 | 5.0 | 8421 0408 49 | -H060U | 8421 0408 47 |
| LBB36 H200 ^a | 22000 | 1/4 | 2.2 | 34.9 | 10.0 | 3/8 | 3/8 | 0.9 | 1.3 | 8421 0408 55 | -H200U | 8421 0408 53 |
| LBB37 H006 | 600 | 1/2 | 2.5 | 44.0 | 10.0 | 3/8 | 3/8 | 1.1 | 48.0 | 8421 0608 06 | -H006U | 8421 0608 14 |
| LBB37 H015 | 1500 | 3/8 | 3.3 | 44.0 | 10.0 | 3/8 | 3/8 | 1.1 | 22.5 | 8421 0608 05 | -H015U | 8421 0608 15 |
| LBB37 H037 | 3700 | 3/8 | 2.5 | 44.0 | 10.0 | 3/8 | 3/8 | 1.1 | 9.2 | 8421 0608 13 | -H037U | 8421 0608 16 |
| LBB37 H065 | 6500 | 1/4 | 2.5 | 44.0 | 10.0 | 3/8 | 3/8 | 1.1 | 5.0 | 8421 0608 11 | -H065U | 8421 0608 17 |
| LBB37 H230 | 23000 | 1/4 | 2.2 | 44.0 | 10.0 | 3/8 | 3/8 | 1.1 | 1.3 | 8421 0608 03 | -H230U | 8421 0608 18 |
| LBB45 H004 ^b | 400 | 5/8 | 9.3 | 21.0 | 10.0 | 3/8 | 1/4 | 0.9 | - | 8421 0501 16 | - | - |
| LBB45 H006 ^b | 600 | 5/8 | 9.3 | 21.0 | 10.0 | 3/8 | 1/4 | 0.9 | - | 8421 0501 24 | -H006U | 8421 0501 40 |
| LBB45 H017 ^b | 1700 | 5/8 | 9.3 | 21.0 | 10.0 | 3/8 | 1/4 | 0.9 | - | 8421 0501 32 | - | - |
| ATEX certified models | | | | | | | | | | | | |
| LBB26 EPX005-ATEX | 500 | 1/2 | 1.8 | 31.8 | 10.0 | 3/8 | 1/4 | 0.7 | - | 8421 0500 22 | - | - |
| LBB26 EPX007-ATEX | 700 | 1/2 | 1.8 | 31.8 | 10.0 | 3/8 | 1/4 | 0.7 | - | 8421 0500 21 | - | - |
| LBB26 EPX013-ATEX | 1300 | 3/8 | 1.7 | 31.8 | 10.0 | 3/8 | 1/4 | 0.7 | - | 8421 0500 20 | - | - |
| LBB26 EPX026-ATEX | 2600 | 5/16 | 1.7 | 31.8 | 10.0 | 3/8 | 1/4 | 0.7 | - | 8421 0500 19 | - | - |

^a Including chuck guard. ^b Including support handle.

Dimensions

LBB EP/EPX/H

| Model | L mm | H mm | C mm | D mm | E mm |
|------------------|---------|---------|---------|---------|---------|
| LBB16 EP/EPX-200 | 177 | 131 | 16.5 | 31.4 | 13.8 |
| LBB16 EP/EPX-060 | 177 | 131 | 16.5 | 31.4 | 13.8 |
| LBB16 EP/EPX-045 | 177 | 131 | 16.5 | 31.4 | 13.8 |
| LBB16 EP/EPX-033 | 177 | 131 | 16.5 | 31.4 | 13.8 |
| LBB16 EP/EPX-024 | 177 | 131 | 16.5 | 31.4 | 13.8 |
| LBB16 EP/EPX-010 | 190 | 131 | 16.5 | 31.4 | 27.0 |
| LBB16 EP/EPX-005 | 190 | 131 | 16.5 | 31.4 | 27.0 |
| LBB16 EP-003 | 190 | 131 | 16.5 | 31.4 | 27.0 |
| LBB26 EPX-060 | 180 | 147 | 21 | 39 | - |
| LBB26 EPX-045 | 180 | 147 | 21 | 39 | - |
| LBB26 EPX-033 | 180 | 147 | 21 | 39 | - |
| LBB26 EPX-026 | 180 | 147 | 21 | 39 | - |
| LBB26 EPX-019 | 196 | 147 | 21 | 39 | - |
| LBB26 EPX-013 | 196 | 147 | 21 | 39 | - |
| LBB26 EPX-007 | 196 | 147 | 21 | 39 | - |
| LBB26 EPX-005 | 196 | 147 | 21 | 39 | - |
| LBB26 EPX-003 | 196 | 147 | 21 | 39 | - |
| LBB36 H200 | 217 | 157 | 23 | 41.5 | 16.5 |
| LBB36 H060 | 217 | 157 | 23 | 41.5 | 16.5 |
| LBB36 H033 | 217 | 157 | 23 | 41.5 | 16.5 |
| LBB36 H026 | 217 | 157 | 23 | 41.5 | 16.5 |
| LBB36 H013 | 256 | 157 | 23 | 41.5 | 64.0 |
| LBB36 H007 | 256 | 157 | 23 | 41.5 | 64.0 |
| LBB36 H005 | 256 | 157 | 23 | 41.5 | 64.0 |
| LBB37 H230 | 217 | 157 | 23 | 41.5 | 16.5 |
| LBB37 H065 | 217 | 157 | 23 | 41.5 | 16.5 |
| LBB37 H037 | 217 | 157 | 23 | 41.5 | 16.5 |
| LBB37 H015 | 256 | 157 | 23 | 41.5 | 64.0 |
| LBB37 H006 | 256 | 157 | 23 | 41.5 | 64.0 |
| LBB45 H006 | 360 | 185 | 33 | 60 | 113 |
| LBB45 H017 | 360 | 185 | 33 | 60 | 113 |
| LBB45 H004 | 360 | 185 | 33 | 60 | 113 |

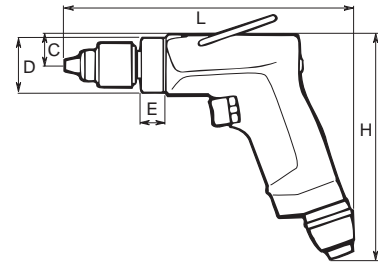

Accessories Included

Chuck, chuck key, hose nipple.

LBB16 and -36/37 with suspension yoke and with chuck guard where possible.

LBB16 and -36/37 have a 3/8" -24 UNF spindle thread.

LBB36 H005 and LBB37 H006 have a 1/2" -20 UNF thread.

LBB45 has a JT3 taper mount.

Optional Accessories

KEY CHUCKS

| Mount | Body diameter mm | Chuck capacity in | Ordering No. | | |
|-----------|---------------------|----------------------|------------------|--------------|-----------------|
| | | | Chuck (key incl) | Key only | Key designation |
| 1/2-20UNF | 43 | 5/8 | 4021 0289 01 | 4021 0465 00 | S2 |
| 3/8-24UNF | 30 | 1/4 | 4021 0283 00 | 4021 0293 00 | S1 |
| 3/8-24UNF | 30 | 5/16 | 4021 0495 00 | 4021 0293 00 | S1 |
| 3/8-24UNF | 36 | 3/8 | 4021 0416 00 | 4021 0449 00 | S8 |
| 3/8-24UNF | 46 | 1/2 | 4021 0289 00 | 4021 0465 00 | S2 |
| JT3 | 59 | 5/8 | 4021 0423 00 | 4021 0301 00 | S3 |



Key chuck

QUICK CHUCKS

| Mount | Chuck dia mm | Chuck capacity in | Ordering No. |
|-----------|-----------------|----------------------|--------------|
| 3/8-24UNF | 34 | 1/4 | 4021 0400 00 |
| 3/8-24UNF | 34 | 5/16 | 4021 0401 00 |
| 3/8-24UNF | 36 | 3/8 | 4021 0402 00 |
| 3/8-24UNF | 36 | 1/2 | 4021 0403 00 |



Quick chuck

Optional Accessories

COLLET CHUCK AND COLLETS

| Designation | Capacity | | Ordering No. |
|-------------|---------------|------|--------------|
| | mm | in | |
| Collet | 3 | | 4150 0081 00 |
| | 6 | | 4150 0075 00 |
| | 8 | 5/16 | 4150 0074 00 |
| | | 1/8 | 4150 0082 00 |
| | | 5/32 | 4150 0648 00 |
| | | 3/16 | 4150 0649 00 |
| | | 1/4 | 4150 0076 00 |
| | Collet holder | | |
| Collet nut | | | 4150 0760 00 |



Collet chuck and collets

CHUCK GUARDS

| For model | Max chuck dia mm | Ordering No. |
|--------------------|------------------|--------------|
| LBB16 ^a | 30 | 4110 1619 04 |
| LBB26 | 36 | 4110 1728 02 |
| LBB26 | 30 | 4110 1728 03 |
| LBB36 ^b | 36 | 4110 1415 00 |
| LBB37 ^b | 36 | 4110 1415 00 |



Chuck guard

^a The guards do not fit 1000 r/min models, 500 r/min and 300 r/min models.

^b The chuck guards do not fit the 500 r/min, 600 r/min or 700 r/min models.

FLEX CONNECT

| For model | Ordering No. |
|-----------|--------------|
| LBB16 | 4110 1601 80 |



Flex connect

SPOT SUCTION ATTACHMENT

| For model | Hose size in | Spot suction kit ^a Ordering No. | Hose kit Ordering No. |
|-----------|--------------|--|-----------------------|
| LBB16 | 1 1/4 | 4110 1715 80 | 4112 1227 00 |
| LBB26 | 1 1/4 | 4110 1715 84 | 4112 1227 00 |
| LBB36/37 | 1 1/4 | 4110 1716 80 | 4112 1227 00 |



Spot suction attachment

^a Spare part, nose piece kit, Ordering No. 4110 1700 90.

Other standard sizes of front nozzle available.

POWER FEED ARM FOR EXTRA FEED FORCE – LBB36 H005 AND LBB37 H006

| | Ordering No. |
|--|--------------|
| Adapter piece (SR295), lever arm (SR201), chain (SR202) and No. 2 Morse socket (SR206) | 4110 1416 80 |
| Two extension pieces (SR204-1 and SR204-2), 370 and 750 mm long | 4110 1417 80 |
| No. 2 Morse socket | 4110 1416 01 |



Power feed arm

Optional Accessories

SUPPORT HANDLES

| For model | Ordering No. |
|-----------|--------------|
| LBB16 | 4110 1355 92 |
| LBB26 | 4110 1355 95 |
| LBB36/37 | 4110 1355 82 |
| LBB45 | 4110 1355 84 |



OPTIONAL ACCESSORIES – LBB45

| Designation | Ordering No. |
|--------------------|--------------|
| No. 2 Morse socket | 4130 1080 00 |

Productivity Kits

| Model | Max air flow | Hose 16.4 ft | Coupling | Lubrication | Ordering No. |
|--------------------------------|--------------|--------------|--------------|-------------|--------------|
| MIDI Optimizer F/R EQ08US-C06 | 12 cfm | Cabclair 06 | ErgoQIC 08US | No | 8202 0850 21 |
| MIDI Optimizer F/RD EQ08US-C06 | 19 cfm | Cabclair 06 | ErgoQIC 08US | Yes | 8202 0850 22 |
| MIDI Optimizer F/RD EQ08US-C08 | 19 cfm | Cabclair 08 | ErgoQIC 08US | Yes | 8202 0850 23 |
| MIDI Optimizer F/R EQ08US-C08 | 19 cfm | Cabclair 08 | ErgoQIC 08US | No | 8202 0850 24 |
| MIDI Optimizer F/RD EQ10US-C10 | 34 cfm | Cabclair 10 | ErgoQIC 10US | Yes | 8202 0850 25 |
| MIDI Optimizer F/RD EQ10US-R10 | 34 cfm | Rubair 10 | ErgoQIC 10US | Yes | 8202 0850 26 |
| MIDI Optimizer F/RD EQ10US-C13 | 50 cfm | Cabclair 13 | ErgoQIC 10US | Yes | 8202 0850 27 |
| MIDI Optimizer F/RD EQ10US-R13 | 50 cfm | Rubair 13 | ErgoQIC 10US | Yes | 8202 0850 28 |

NOTE: Tool nipple is not included in the Productivity kit and needs to be order separately together with the tool.



Service Kits

| | |
|-----------|--------------|
| LBB16 | 4081 0271 90 |
| LBB26 | 4081 2028 90 |
| LGB/LBV34 | 4081 0035 90 |
| LBB36/37 | 4081 0194 90 |
| LBB45 | 4081 0139 90 |

Atlas Copco straight drills are primarily intended for vertical drilling operations and for drilling in cramped spaces.

- Quiet – Very low noise level.
- Very high power to weight ratio.
- Adjustable exhaust –The exhaust air is directed away from the operator.
- Lubrication-free – LBB16 drills are lubrication-free for clean working environment and operator comfort.



LBB16

| Model | Free speed ^a r/min | Chuck capacity in | Weight lb | Air consumption at free speed cfm | Hose size | | Air inlet thread NPT | Power hp | With chuck Ordering No. | Without chuck | |
|---------------------------------|----------------------------------|----------------------|--------------|---|-----------|-----|----------------------------|-------------|----------------------------|---------------|--------------|
| | | | | | mm | in | | | | Model | Ordering No. |
| Drills with rear exhaust | | | | | | | | | | | |
| LBB16 S260 | 26000 | 1/4 | 1.1 | 17 | 6.3 | 1/4 | 1/4 | 0.47 | 8421 0210 00 | S260-U | 8421 0210 10 |
| LBB16 S064 | 6400 | 1/4 | 1.1 | 17 | 6.3 | 1/4 | 1/4 | 0.47 | 8421 0210 01 | S064-U | 8421 0210 11 |
| LBB16 S045 | 4500 | 1/4 | 1.1 | 17 | 6.3 | 1/4 | 1/4 | 0.47 | 8421 0210 02 | S045-U | 8421 0210 12 |
| LBB16 S038 | 3800 | 1/4 | 1.1 | 17 | 6.3 | 1/4 | 1/4 | 0.47 | 8421 0210 03 | S038-U | 8421 0210 13 |
| LBB16 S029 | 2900 | 5/16 | 1.2 | 17 | 6.3 | 1/4 | 1/4 | 0.47 | 8421 0210 04 | S029-U | 8421 0210 14 |
| LBB16 S022 | 2200 | 3/8 | 1.5 | 17 | 6.3 | 1/4 | 1/4 | 0.47 | 8421 0210 05 | S022-U | 8421 0210 15 |
| LBB16 S012 | 1200 | 3/8 | 1.5 | 17 | 6.3 | 1/4 | 1/4 | 0.47 | 8421 0210 06 | S012-U | 8421 0210 16 |

^a The free speed can be reduced to 50% of the maximum speed using the trim valve.

Dimensions

| Model | L | H | A |
|------------|-----|----|-----|
| LBB16 S260 | 196 | 39 | 146 |
| LBB16 S064 | 196 | 39 | 146 |
| LBB16 S045 | 196 | 39 | 146 |
| LBB16 S038 | 196 | 39 | 146 |
| LBB16 S029 | 196 | 39 | 146 |
| LBB16 S022 | 219 | 39 | 159 |
| LBB16 S012 | 219 | 39 | 159 |

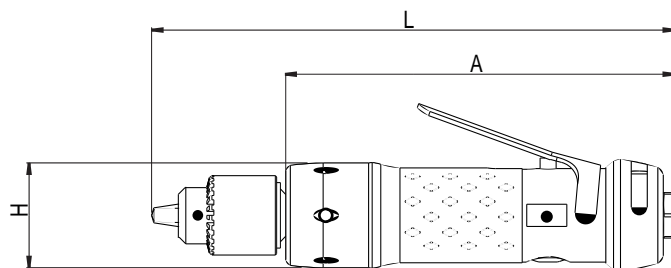

Accessories Included

Chuck, chuck key
Suspension yoke and chuck guard

Optional Accessories

KEY CHUCKS

| Mount | Body diameter mm | Chuck capacity in | Ordering No. | | |
|-----------|---------------------|----------------------|---------------------|--------------|--------------------|
| | | | Chuck (key incl) | Key only | Key designation |
| 1/2-20UNF | 43 | 5/8 | 4021 0289 01 | 4021 0465 00 | S2 |
| 3/8-24UNF | 30 | 1/4 | 4021 0283 00 | 4021 0293 00 | S1 |
| 3/8-24UNF | 30 | 5/16 | 4021 0495 00 | 4021 0293 00 | S1 |
| 3/8-24UNF | 36 | 3/8 | 4021 0416 00 | 4021 0449 00 | S8 |
| 3/8-24UNF | 46 | 1/2 | 4021 0289 00 | 4021 0465 00 | S2 |
| JT3 | 59 | 5/8 | 4021 0423 00 | 4021 0301 00 | S3 |



Key chuck

QUICK CHUCKS

| Mount | Chuck dia mm | Chuck capacity in | Ordering No. |
|-----------|-----------------|----------------------|--------------|
| 3/8-24UNF | 34 | 1/4 | 4021 0400 00 |
| 3/8-24UNF | 34 | 5/16 | 4021 0401 00 |
| 3/8-24UNF | 36 | 3/8 | 4021 0402 00 |
| 3/8-24UNF | 36 | 1/2 | 4021 0403 00 |



Quick chuck

COLLET CHUCK AND COLLETS

| Designation | Capacity | | Ordering No. |
|-------------|---------------|------|--------------|
| | mm | in | |
| Collet | 3 | | 4150 0081 00 |
| | 6 | | 4150 0075 00 |
| | 8 | 5/16 | 4150 0074 00 |
| | | 1/8 | 4150 0082 00 |
| | | 5/32 | 4150 0648 00 |
| | | 3/16 | 4150 0649 00 |
| | | 1/4 | 4150 0076 00 |
| | Collet holder | | |
| Collet nut | | | 4150 0760 00 |



Collet chuck and collets

SAFETY LEVER

| For model | Ordering No. |
|-----------|--------------|
| LBB16S | 4110 1787 90 |



Safety lever



Service Kits

LBB16 4081 0438 90

- Quiet – Very low noise level.
- Low air consumption – Good operating economy.
- Side exhaust – The air can be directed to suit the operator.
- Rear exhaust – The air is piped away through a pliant hose.
- Lubrication-free – For clean working environment and operator comfort.
- Collet chuck or threaded spindle.
- Multiple lever options.



| Model | Free speed r/min | Setting range rpm | Collet or chuck capacity in | Weight lb | Air consumption at free speed cfm | Hose dimension | | Air inlet thread NPT | Power hp | Ordering No. |
|--|---------------------|-------------------------|-----------------------------------|--------------|---|-------------------|-----|----------------------------|-------------|--------------|
| | | | | | | mm | in | | | |
| 30° angle head | | | | | | | | | | |
| LBV11 S029-S30 | 2900 | – | 13/64 | 1.1 | 8.5 | 5.0 | 1/8 | 1/8 | 0.16 | 8421 0108 70 |
| LBV16 032-30 | 3200 | 1500-3200 | 13/64 | 1.1 | 18.4 | 6.3 | 1/4 | 1/4 | 0.4 | 8421 0110 05 |
| LBV16 032-S30 | 3200 | 1500-3200 | 13/64 | 1.0 | 18.4 | 6.3 | 1/4 | 1/4 | 0.4 | 8421 0110 04 |
| LBV16 032-32 | 3200 | 1500-3200 | c | 1.1 | 18.4 | 6.3 | 1/4 | 1/4 | 0.4 | 8421 0110 07 |
| LBV16 032-S32 | 3200 | 1500-3200 | c | 1.0 | 18.4 | 6.3 | 1/4 | 1/4 | 0.4 | 8421 0110 06 |
| LBV16 045-30 | 4500 | 3200-4500 | 13/64 | 1.1 | 18.4 | 6.3 | 1/4 | 1/4 | 0.4 | 8421 0110 71 |
| LBV36 S030-30 ^e | 3000 | – | 13/64 | 2.2 | 36.0 | 10.0 | 3/8 | 1/4 | 0.73 | 8421 0414 70 |
| 45° angle head | | | | | | | | | | |
| LBV16 032-45 | 3200 | 1500-3200 | 13/64 | 1.1 | 18.4 | 6.3 | 1/4 | 1/4 | 0.4 | 8421 0110 59 |
| LBV16 032-46 | 3200 | 1500-3200 | c | 1.1 | 18.4 | 6.3 | 1/4 | 1/4 | 0.4 | 8421 0110 60 |
| 90° angle head | | | | | | | | | | |
| LBV11 S029-S90 | 2900 | – | 13/64 | 1.1 | 8.5 | 5.0 | 1/8 | 1/8 | 0.16 | 8421 0109 79 |
| LBV16 032-90 | 3200 | 1500-3200 | 13/64 | 1.1 | 18.4 | 6.3 | 1/4 | 1/4 | 0.4 | 8421 0110 00 |
| LBV16 032-S90 | 3200 | 1500-3200 | 13/64 | 1.0 | 18.4 | 6.3 | 1/4 | 1/4 | 0.4 | 8421 0110 01 |
| LBV16 032-92 | 3200 | 1500-3200 | c | 1.1 | 18.4 | 6.3 | 1/4 | 1/4 | 0.4 | 8421 0110 03 |
| LBV16 032-S92 | 3200 | 1500-3200 | c | 1.0 | 18.4 | 6.3 | 1/4 | 1/4 | 0.4 | 8421 0110 02 |
| LBV16 045-90 | 4500 | 3200-4500 | 13/64 | 1.1 | 18.4 | 6.3 | 1/4 | 1/4 | 0.4 | 8421 0110 20 |
| LBV16 045-92 | 4500 | 3200-4500 | c | 1.1 | 18.4 | 6.3 | 1/4 | 1/4 | 0.4 | 8421 0110 21 |
| LBV16 055-90 | 5500 | 4500-5500 | 13/64 | 1.1 | 18.4 | 6.3 | 1/4 | 1/4 | 0.4 | 8421 0110 23 |
| LBV16 055-S92 | 5500 | 4500-5500 | c | 1.0 | 18.4 | 6.3 | 1/4 | 1/4 | 0.4 | 8421 0110 58 |
| LBV36 S030-90 ^e | 3000 | – | 13/64 | 2.2 | 36.0 | 10.0 | 3/8 | 1/4 | 0.73 | 8421 0414 60 |
| LBV36 S030-92 ^e | 3000 | – | c | 2.2 | 36.0 | 10.0 | 3/8 | 1/4 | 0.73 | 8421 0414 64 |
| LBV36 S045-90 ^e | 4500 | – | 13/64 | 2.2 | 36.0 | 10.0 | 3/8 | 1/4 | 0.73 | 8421 0414 62 |
| 360° angle head | | | | | | | | | | |
| LBV16 032-90Z | 3200 | 1500-3200 | 13/64 | 1.1 | 18.4 | 6.3 | 1/4 | 1/4 | 0.4 | 8421 0110 64 |
| LBV16 032-92Z | 3200 | 1500-3200 | c | 1.1 | 18.4 | 6.3 | 1/4 | 1/4 | 0.4 | 8421 0110 68 |
| 90° angle head – large angle head | | | | | | | | | | |
| LBV16 005-91 | 500 | 200-500 | 1/4 | 1.2 | 18.4 | 6.3 | 1/4 | 1/4 | 0.4 | 8421 0110 11 |
| LBV16 005-93 | 500 | 200-500 | c | 1.2 | 18.4 | 6.3 | 1/4 | 1/4 | 0.4 | 8421 0110 12 |
| LBV16 010-91 | 1000 | 500-1000 | 1/4 | 1.2 | 18.4 | 6.3 | 1/4 | 1/4 | 0.4 | 8421 0110 16 |
| LBV16 010-93 | 1000 | 500-1000 | c | 1.2 | 18.4 | 6.3 | 1/4 | 1/4 | 0.4 | 8421 0110 17 |
| LBV16 018-91 | 1800 | 800-1800 | 1/4 | 1.2 | 18.4 | 6.3 | 1/4 | 1/4 | 0.4 | 8421 0110 18 |
| LBV16 018-93 | 1800 | 800-1800 | c | 1.2 | 18.4 | 6.3 | 1/4 | 1/4 | 0.4 | 8421 0110 19 |
| LBV16 032-91 | 3200 | 1500-3200 | 1/4 | 1.2 | 18.4 | 6.3 | 1/4 | 1/4 | 0.4 | 8421 0110 09 |
| LBV16 032-93 | 3200 | 1500-3200 | c | 1.2 | 18.4 | 6.3 | 1/4 | 1/4 | 0.4 | 8421 0110 10 |
| LBV16 032-S93 | 3200 | 1500-3200 | c | 1.2 | 18.4 | 6.3 | 1/4 | 1/4 | 0.4 | 8421 0110 39 |
| LBV16 045-91 | 4500 | 3200-4500 | 1/4 | 1.2 | 18.4 | 6.3 | 1/4 | 1/4 | 0.4 | 8421 0110 38 |
| LBV36 S030-91 ^e | 3000 | – | 1/4 | 2.2 | 36.0 | 10.0 | 3/8 | 1/4 | 0.73 | 8421 0414 50 |
| LBV36 S060-91 ^e | 6000 | – | 1/4 | 2.2 | 36.0 | 10.0 | 3/8 | 1/4 | 0.73 | 8421 0414 51 |
| LBV36 S030-93 ^e | 3000 | – | c | 2.2 | 36.0 | 10.0 | 3/8 | 1/4 | 0.73 | 8421 0414 52 |
| LBV36 S060-93 ^e | 6000 | – | c | 2.2 | 36.0 | 10.0 | 3/8 | 1/4 | 0.73 | 8421 0414 53 |
| 90° angle head – Key chuck models | | | | | | | | | | |
| LBV16 018-11 | 1800 | 800-1800 | 5/16 | 1.7 | 18.4 | 6.3 | 1/4 | 1/4 | 0.4 | 8421 0110 22 |
| LBV34 S005 ^b | 500 | – | 1/2 ^a | 4.6 | 15.9 | 10.0 | 3/8 | 1/4 | 0.6 | 8421 0309 04 |
| LBV34 S010 ^b | 1000 | – | 3/8 ^a | 4.4 | 15.9 | 10.0 | 3/8 | 1/4 | 0.6 | 8421 0309 12 |
| LBV34 S040 ^b | 4000 | – | 1/4 ^a | 3.3 | 15.9 | 10.0 | 3/8 | 1/4 | 0.6 | 8421 0309 46 |
| 90° angle head – heavy-duty | | | | | | | | | | |
| LBV37 030 | 3000 | – | c | 2.4 | 46 | 10.0 | 3/8 | 3/8 | 1.1 | 8421 0414 54 |
| LBV37 HD030 | 3000 | – | d | 2.4 | 46 | 10.0 | 3/8 | 3/8 | 1.1 | 8421 0414 56 |

^a Spindle thread, male 3/8"-24 UNF. ^b Side exhaust. ^c Internal thread 1/4"-28. ^d Internal thread 5/16". ^e Short lever as standard.

Dimensions

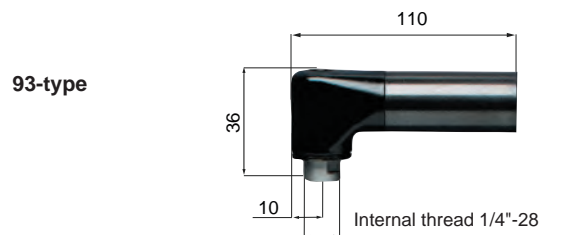
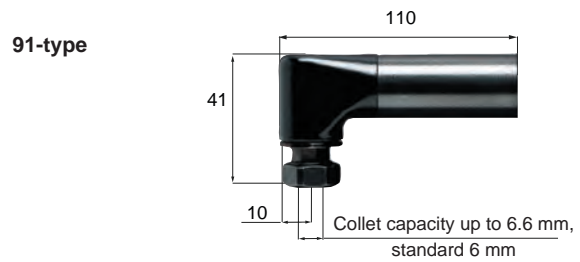
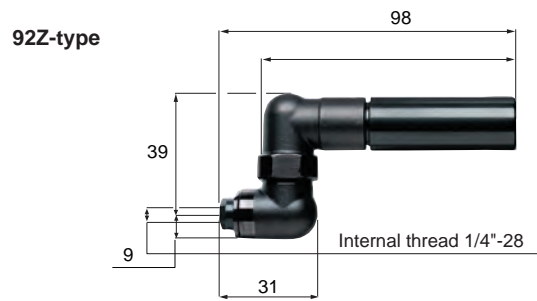
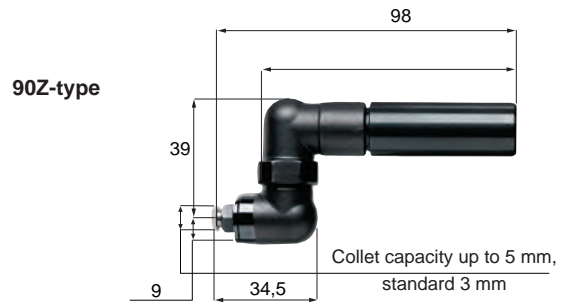
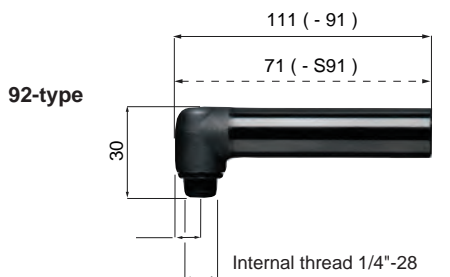
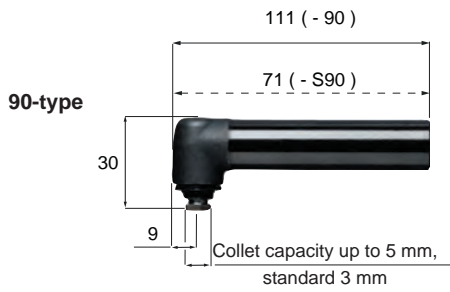
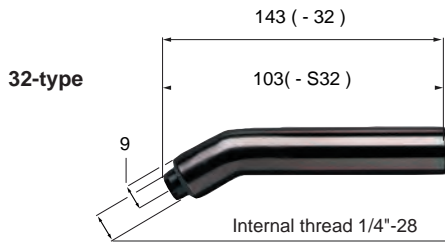
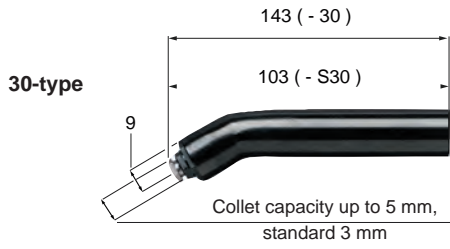

Dimensions

DRILLING CAPACITY

| Model | Angle head mm | | | | |
|----------------|---------------|-----|----|-----|----|
| | A | B | C | L | H |
| LBV11 S027-S30 | 59 | 25 | 18 | 224 | 30 |
| LBV11 S025-S90 | 44 | 30 | 18 | 204 | 30 |
| LBV16 032-S30 | 103 | 25 | 17 | 241 | 42 |
| LBV16 032-30 | 143 | 25 | 17 | 281 | 42 |
| LBV16 032-S32 | 103 | 25 | 17 | 241 | 42 |
| LBV16 032-32 | 143 | 25 | 17 | 281 | 42 |
| LBV16 032-90 | 111 | 30 | 17 | 248 | 42 |
| LBV16 032-S90 | 71 | 30 | 17 | 209 | 42 |
| LBV16 032-S92 | 71 | 30 | 17 | 209 | 42 |
| LBV16 032-92 | 111 | 30 | 17 | 249 | 42 |
| LBV16 032-90Z | 145 | 48 | 17 | 283 | 42 |
| LBV16 032-91 | 110 | 39 | 20 | 248 | 42 |
| LBV16 032-93 | 110 | 36 | 20 | 248 | 42 |
| LBV16 005-91 | 110 | 39 | 20 | 248 | 42 |
| LBV16 005-93 | 110 | 36 | 20 | 248 | 42 |
| LBV16 010-91 | 110 | 39 | 20 | 248 | 42 |
| LBV16 010-93 | 110 | 36 | 20 | 248 | 42 |
| LBV16 018-91 | 110 | 39 | 20 | 248 | 42 |
| LBV16 018-93 | 110 | 36 | 20 | 248 | 42 |
| LBV34 S040 | 92 | 97 | 20 | 255 | 43 |
| LBV34 S010 | 92 | 114 | 20 | 290 | 43 |
| LBV34 S005 | 92 | 120 | 20 | 290 | 43 |
| LBV36 S030-91 | 92 | 41 | 20 | 252 | 43 |
| LBV36 S060-91 | 92 | 41 | 20 | 252 | 43 |
| LBV36 S030-93 | 92 | 36 | 20 | 252 | 43 |
| LBV36 S060-93 | 92 | 36 | 20 | 252 | 43 |
| LBV36 S030-30 | 122 | 26 | 18 | 281 | 43 |
| LBV36 S045-30 | 122 | 26 | 18 | 281 | 43 |
| LBV36 S030-90 | 112 | 30 | 18 | 272 | 43 |
| LBV36 S045-90 | 112 | 30 | 18 | 272 | 43 |
| LBV36 S030-92 | 112 | 30 | 18 | 272 | 43 |
| LBV37 030 | 55 | 39 | 23 | 262 | 43 |
| LBV37 HD030 | 55 | 39 | 23 | 262 | 43 |

LBV11, -16, -36
30°

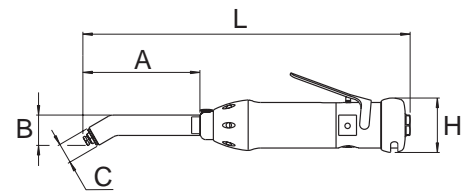

LBV11, -16, -36
90°

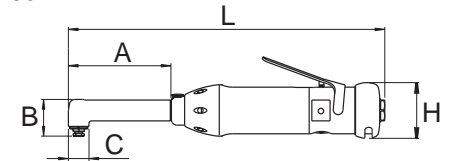

LBV16, -25
360°

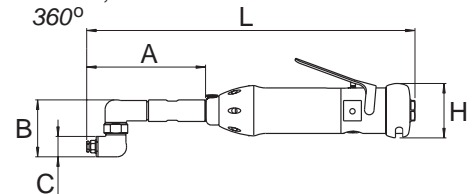

LBV34
90°

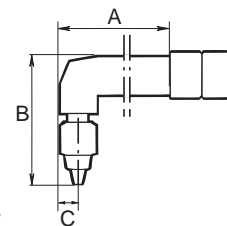

LBV37
90°

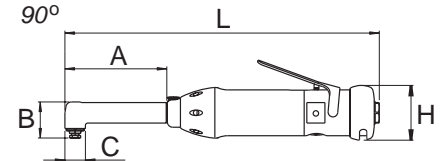

Accessories Included

KEY WRENCHES

Collet or chuck with key
3 mm collet (5.0 collet capacity head)
6 mm collet (6.6 collet capacity head)

Optional Accessories

SAFETY LEVERS

| For model | Ordering No. |
|-----------|--------------|
| LBV16 | 4110 1787 90 |
| LBV36/37 | 4150 1594 97 |



Safety lever

SHORT LEVERS

| For model | Ordering No. |
|-----------|--------------|
| LBV16 | 4210 2306 04 |



Short lever

COLLETS FOR 5.0 MM CAPACITY HEAD LBV11, LBV16 – (-30, -90, -90Z) AND LBV36 (-30, -90)

| Capacity mm | Ordering No. | Capacity mm | Ordering No. | Capacity in | Ordering No. |
|-------------|--------------|-------------|--------------|-------------|--------------|
| 1.0 | 4110 0438 01 | 3.4 | 4110 0438 33 | 1/16 | 4110 0438 19 |
| 1.5 | 4110 0438 02 | 3.5 | 4110 0438 13 | 3/32 | 4110 0438 20 |
| 1.8 | 4110 0438 28 | 3.6 | 4110 0438 24 | 1/8 | 4110 0438 21 |
| 2.0 | 4110 0438 03 | 3.7 | 4110 0438 34 | 5/32 | 4110 0438 22 |
| 2.1 | 4110 0438 29 | 3.8 | 4110 0438 14 | 3/16 | 4110 0438 23 |
| 2.2 | 4110 0438 04 | 3.9 | 4110 0438 35 | | |
| 2.3 | 4110 0438 30 | 4.0 | 4110 0438 15 | | |
| 2.4 | 4110 0438 05 | 4.1 | 4110 0438 25 | | |
| 2.5 | 4110 0438 06 | 4.2 | 4110 0438 26 | | |
| 2.6 | 4110 0438 07 | 4.3 | 4110 0438 36 | | |
| 2.7 | 4110 0438 31 | 4.4 | 4110 0438 37 | | |
| 2.8 | 4110 0438 32 | 4.5 | 4110 0438 16 | | |
| 2.9 | 4110 0438 08 | 4.6 | 4110 0438 38 | | |
| 3.0 | 4110 0438 09 | 4.7 | 4110 0438 39 | | |
| 3.1 | 4110 0438 10 | 4.8 | 4110 0438 18 | | |
| 3.2 | 4110 0438 11 | 4.9 | 4110 0438 40 | | |
| 3.3 | 4110 0438 12 | 5.0 | 4110 0438 27 | | |

Collets for 5.0 mm (Thread BSF 9/32 -40)

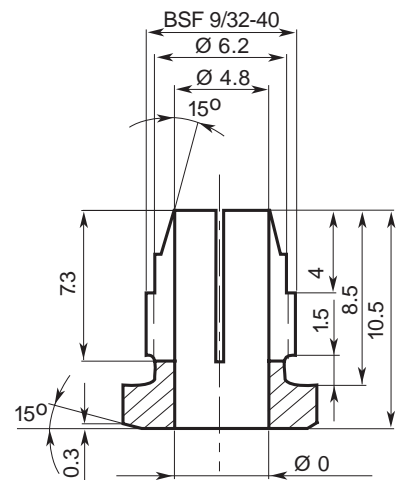

COLLETS FOR 6.6 MM CAPACITY HEAD LBV16 (-91) AND LBV36 (-91)

| Capacity mm | Ordering No. | Capacity mm | Ordering No. |
|-------------|--------------|-------------|--------------|
| 1.6 | 4110 1411 01 | 4.2 | 4110 1411 14 |
| 1.8 | 4110 1411 02 | 4.4 | 4110 1411 15 |
| 2.0 | 4110 1411 03 | 4.6 | 4110 1411 16 |
| 2.2 | 4110 1411 04 | 4.8 | 4110 1411 17 |
| 2.4 | 4110 1411 05 | 5.0 | 4110 1411 18 |
| 2.6 | 4110 1411 06 | 5.2 | 4110 1411 19 |
| 2.8 | 4110 1411 07 | 5.4 | 4110 1411 20 |
| 3.0 | 4110 1411 08 | 5.6 | 4110 1411 21 |
| 3.2 | 4110 1411 09 | 5.8 | 4110 1411 22 |
| 3.4 | 4110 1411 10 | 6.0 | 4110 1411 23 |
| 3.6 | 4110 1411 11 | 6.2 | 4110 1411 24 |
| 3.8 | 4110 1411 12 | 6.4 | 4110 1411 25 |
| 4.0 | 4110 1411 13 | 6.6 | 4110 1411 26 |

Collets for 6.6 mm

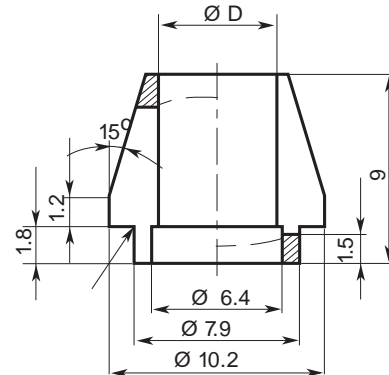

Collet nut 4110 1410 00, to be ordered separately.



Service Kits

| | |
|-------------------|--------------|
| LBV16 | 4081 0322 90 |
| LBV24 | 4081 0005 90 |
| LBV25 | 4081 0272 90 |
| LGB/LBV34 | 4081 0035 90 |
| LBV36 (30, 90/92) | 4081 0263 90 |
| LBV36 (91/93) | 4081 0251 90 |
| LBV37 | 4081 0431 90 |

The LBD16M and LBP16M are designed with the operator in focus. A lightweight tool with a powerful air motor combined with interchangeable angle heads equals excellent flexibility in any handheld drilling operation. Swap to a new head in a matter of seconds with the easy-to-use quick change mechanism. With the LBD16M and LBP16M, you are always ready to take on any job in ever changing drilling applications.

- Quick change system – Easy-to-use and robust quick change design for high durability.
- Indexable head – The head can be positioned in any direction for maximum accessibility.
- High power lubrication free motor – No more oil aerosols, for a safer and cleaner working environment.



LBP16M

LBD16M

| Model | Free speed ^a rpm | Motor speed ^b | Weight lb | Air consumption cfm | Hose size | | Air inlet thread NPT | Power hp | Ordering No. |
|-----------------------------|--------------------------------|--------------------------|--------------|------------------------|-----------|-----|----------------------------|-------------|--------------|
| | | | | | mm | in | | | |
| Straight motor units | | | | | | | | | |
| LBD16M-005 | 500 | 600 | 1.25 | 18.4 | 6.3 | 1/4 | 1/4 | 0.4 | 8421 0122 05 |
| LBD16M-010 | 1000 | 1200 | 1.25 | 18.4 | 6.3 | 1/4 | 1/4 | 0.4 | 8421 0122 10 |
| LBD16M-018 | 1800 | 2100 | 1.25 | 18.4 | 6.3 | 1/4 | 1/4 | 0.4 | 8421 0122 18 |
| LBD16M-032 | 3200 | 3600 | 1 | 18.4 | 6.3 | 1/4 | 1/4 | 0.4 | 8421 0122 32 |
| LBD16M-045 | 4500 | 5100 | 1 | 18.4 | 6.3 | 1/4 | 1/4 | 0.4 | 8421 0122 45 |
| LBD16M-055 | 5500 | 6200 | 1 | 18.4 | 6.3 | 1/4 | 1/4 | 0.4 | 8421 0122 55 |
| Pistol motor units | | | | | | | | | |
| LBP16M-005 | 500 | 600 | 1.2 | 20.0 | 6.3 | 1/4 | 1/4 | 0.45 | 8421 0124 05 |
| LBP16M-010 | 1000 | 1100 | 1.2 | 20.0 | 6.3 | 1/4 | 1/4 | 0.45 | 8421 0124 10 |
| LBP16M-018 | 1800 | 2100 | 1.2 | 20.0 | 6.3 | 1/4 | 1/4 | 0.45 | 8421 0124 18 |
| LBP16M-033 | 3300 | 3700 | 1.1 | 20.0 | 6.3 | 1/4 | 1/4 | 0.45 | 8421 0124 33 |
| LBP16M-045 | 4500 | 5100 | 1.1 | 20.0 | 6.3 | 1/4 | 1/4 | 0.45 | 8421 0124 45 |
| LBP16M-060 | 6000 | 6800 | 1.1 | 20.0 | 6.3 | 1/4 | 1/4 | 0.45 | 8421 0124 60 |

^a The free speed is given when used with a 90° angle head. ^b Multiply this value with the Speed ratio to get the free speed of each angle head.

ANGLE HEADS

| Model | Angle head | Weight lb | Collet capacity | Thread in | Speed ratio | Length | | Ordering No. |
|---|------------|--------------|-----------------|--------------|-------------|--------|------|--------------|
| | | | | | | mm | in | |
| Angle heads with collet – Short | | | | | | | | |
| BHM90SC-5-0 | 90° | 0.5 | 5.0 | – | 14:16 | 65.5 | 2.58 | 8421 0123 02 |
| Angle heads with collet – Standard | | | | | | | | |
| BHM90C-5-0 | 90° | 0.36 | 5.0 | – | 14:16 | 88.5 | 3.48 | 8421 0123 00 |
| BHM90C-6-6 | 90° | 0.55 | 6.6 | – | 14:16 | 89.6 | 3.53 | 8421 0123 05 |
| BHM90C-8-0 | 90° | 0.55 | 8.0 | – | 14:17 | 89.7 | 3.54 | 8421 0123 80 |
| BHM45C-5-0 | 45° | 0.44 | 5.0 | – | 14:15 | 117.3 | 4.62 | 8421 0123 10 |
| BHM30C-5-0 | 30° | 0.44 | 5.0 | – | 14:15 | 120.4 | 4.74 | 8421 0123 20 |
| BHM30C-6-6 | 30° | 0.44 | 6.6 | – | 14:15 | 127 | 5 | 8421 0123 15 |
| BHM90ZC-5-0 | 360° | 0.47 | 5.0 | – | 7:9 | 100.8 | 3.97 | 8421 0123 30 |
| BHM90ZC-6-6 | 360° | 0.47 | 6.6 | – | 7:9 | 108 | 4.25 | 8421 0123 40 |
| Angle heads with collet – Extended | | | | | | | | |
| BHM90EC-5-0 | 90° | 0.58 | 5.0 | – | 14:16 | 128.5 | 5.06 | 8421 0123 08 |
| BHM45EC-5-0 | 45° | 0.64 | 5.0 | – | 14:15 | 157.3 | 6.19 | 8421 0123 18 |
| BHM30EC-5-0 | 30° | 0.64 | 5.0 | – | 14:15 | 160.4 | 6.31 | 8421 0123 28 |
| BHM90Ezc-5-0 | 360° | 0.67 | 5.0 | – | 7:9 | 140.8 | 5.54 | 8421 0123 38 |
| Angle head with internal thread – Standard | | | | | | | | |
| BHM90T-1-4 | 90° | 0.36 | – | 1/4"-28 | 14:16 | 88.5 | 3.48 | 8421 0123 01 |
| BHM90LT-1-4 | 90° | 0.52 | – | 1/4"-28 | 14:16 | 89.6 | 3.53 | 8421 0123 06 |
| BHM45T-1-4 | 45° | 0.44 | – | 1/4"-28 | 14:15 | 118.2 | 4.65 | 8421 0123 11 |
| BHM30T-1-4 | 30° | 0.44 | – | 1/4"-28 | 14:15 | 121.1 | 4.77 | 8421 0123 21 |
| BHM90ZT-1-4 | 360° | 0.47 | – | 1/4"-28 | 7:9 | 101 | 3.98 | 8421 0123 31 |
| Angle head with internal thread – Extended | | | | | | | | |
| BHM90ET-1-4 | 90° | 0.58 | – | 1/4"-28 | 14:16 | 128.5 | 5.06 | 8421 0123 09 |
| BHM45ET-1-4 | 45° | 0.64 | – | 1/4"-28 | 14:15 | 157.9 | 6.22 | 8421 0123 19 |
| BHM30ET-1-4 | 30° | 0.64 | – | 1/4"-28 | 14:15 | 161.1 | 6.34 | 8421 0123 29 |
| BHM90EZT-1-4 | 360° | 0.67 | – | 1/4"-28 | 7:9 | 141 | 5.55 | 8421 0123 39 |
| Straight short angle head | | | | | | | | |
| BHM0C-5-0 | 0° | 0.31 | 5.0 | – | 1:1 | 78 | 3.07 | 8421 0123 43 |
| BHM0T-1-4 | 0° | 0.31 | – | 1/4"-28 | 1:1 | 78 | 3.07 | 8421 0123 44 |

Angle heads Standard/Extended (pictures shows extended versions)



Dimensions

ANGLE HEAD DIMENSIONS

| Model | A mm | B mm | C mm | L mm | H mm | Ordering No. |
|------------------------------|-------|------|------|-------|------|--------------|
| 90° heads | | | | | | |
| BHM90SC-5-0 | 65.5 | 29.8 | 17 | 106.2 | 19.8 | 8421 0123 02 |
| BHM90C-5-0 | 88.5 | 29.8 | 17 | 129.2 | 19.8 | 8421 0123 00 |
| BHM90C-6-6 | 90 | 39.3 | 20 | 130.3 | 20 | 8421 0123 05 |
| BHM90C-8-0 | 90 | 41.1 | 20 | 130.3 | 20 | 8421 0123 80 |
| BHM90EC-5-0 | 128.5 | 29.8 | 17 | 169.2 | 19.8 | 8421 0123 08 |
| BHM90T-1-4 | 88.5 | 30 | 17 | 129.2 | 19.8 | 8421 0123 01 |
| BHM90LT-1-4 | 90 | 36 | 20 | 130.3 | 20 | 8421 0123 06 |
| BHM90ET-1-4 | 128.5 | 30 | 14 | 169.2 | 19.8 | 8421 0123 09 |
| 30° heads | | | | | | |
| BHM30C-5-0 | 120.4 | 25 | 17 | 161 | 19.8 | 8421 0123 20 |
| BHM30C-6-6 | 127.3 | 32.3 | 17 | 168 | 19.8 | 8421 0123 15 |
| BHM30EC-5-0 | 160.4 | 25.2 | 17 | 201 | 19.8 | 8421 0123 28 |
| BHM30T-1-4 | 121.1 | 26.4 | 17 | 161.6 | 19.8 | 8421 0123 21 |
| BHM30ET-1-4 | 161.1 | 26.4 | 17 | 201.8 | 19.8 | 8421 0123 29 |
| 45° heads | | | | | | |
| BHM45C-5-0 | 117.3 | 30.5 | 17 | 158 | 19.8 | 8421 0123 10 |
| BHM45EC-5-0 | 157.3 | 30.5 | 17 | 198 | 19.8 | 8421 0123 18 |
| BHM45T-1-4 | 118.2 | 31.4 | 17 | 159 | 19.8 | 8421 0123 11 |
| BHM45ET-1-4 | 158.2 | 31.4 | 17 | 199 | 19.8 | 8421 0123 19 |
| 360° heads | | | | | | |
| BHM90ZC-5-0 | 100.8 | 45.9 | 17 | 141.5 | 19.8 | 8421 0123 30 |
| BHM90ZC-6-6 | 107.3 | 45.9 | 17 | 148 | 19.8 | 8421 0123 40 |
| BHM90EZC-5-0 | 140.8 | 45.9 | 17 | 181.5 | 19.8 | 8421 0123 38 |
| BHM90ZT-1-4 | 101 | 45.9 | 17 | 141.5 | 19.8 | 8421 0123 31 |
| BHM90EZT-1-4 | 141 | 45.9 | 17 | 181.5 | 19.8 | 8421 0123 39 |
| Straight heads | | | | | | |
| BHM0C-5-0 | 78 | - | 17 | 119 | 19.8 | 8421 0123 43 |
| BHM0T-1-4 | 78 | - | 17 | 119 | 19.8 | 8421 0123 44 |
| Extension - for chuck | | | | | | |
| EXTENSION | 35 | - | 17.5 | 76 | 28.5 | 4110 1692 90 |

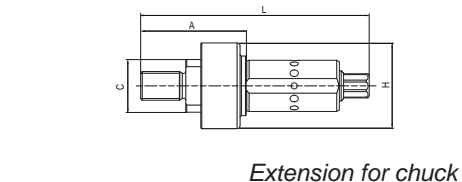
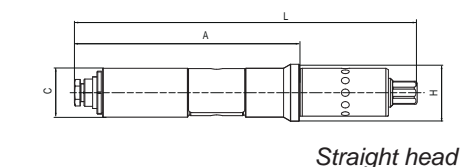
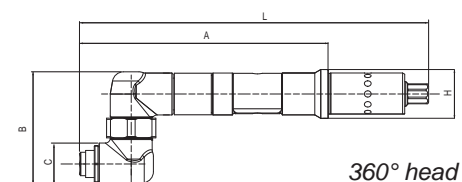
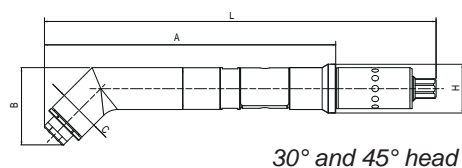
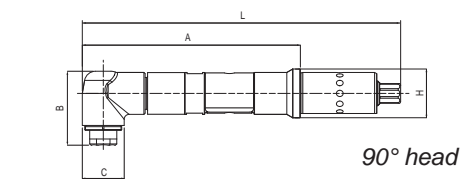

Optional Accessories



STRAIGHT DRILL HEAD FOR CHUCK

| For model | Ordering No. |
|----------------|--------------|
| LBD16M, LBP16M | 4110 1692 90 |

SAFETY LEVERS

| For model | Ordering No. |
|-----------|--------------|
| LBD16M | 4110 1787 80 |



SHORT LEVERS

| For model | Ordering No. |
|-----------|--------------|
| LBD16M | 4210 2306 04 |

COLLETS FOR 5.0 MM CAPACITY ANGLE HEAD BHMC-5-0 (-30, -45, -90, -90Z)

| Capacity mm | Ordering No. | Capacity mm | Ordering No. | Capacity in | Ordering No. |
|-------------|--------------|-------------|--------------|-------------|--------------|
| 1.0 | 4110 0438 01 | 3.4 | 4110 0438 33 | 1/16 | 4110 0438 19 |
| 1.5 | 4110 0438 02 | 3.5 | 4110 0438 13 | 3/32 | 4110 0438 20 |
| 1.8 | 4110 0438 28 | 3.6 | 4110 0438 24 | 1/8 | 4110 0438 21 |
| 2.0 | 4110 0438 03 | 3.7 | 4110 0438 34 | 5/32 | 4110 0438 22 |
| 2.1 | 4110 0438 29 | 3.8 | 4110 0438 14 | 3/16 | 4110 0438 23 |
| 2.2 | 4110 0438 04 | 3.9 | 4110 0438 35 | | |
| 2.3 | 4110 0438 30 | 4.0 | 4110 0438 15 | | |
| 2.4 | 4110 0438 05 | 4.1 | 4110 0438 25 | | |
| 2.5 | 4110 0438 06 | 4.2 | 4110 0438 26 | | |
| 2.6 | 4110 0438 07 | 4.3 | 4110 0438 36 | | |
| 2.7 | 4110 0438 31 | 4.4 | 4110 0438 37 | | |
| 2.8 | 4110 0438 32 | 4.5 | 4110 0438 16 | | |
| 2.9 | 4110 0438 08 | 4.6 | 4110 0438 38 | | |
| 3.0 | 4110 0438 09 | 4.7 | 4110 0438 39 | | |
| 3.1 | 4110 0438 10 | 4.8 | 4110 0438 18 | | |
| 3.2 | 4110 0438 11 | 4.9 | 4110 0438 40 | | |
| 3.3 | 4110 0438 12 | 5.0 | 4110 0438 27 | | |

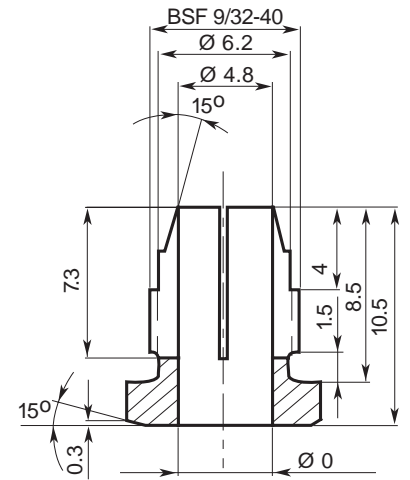

Collets for 5.0 mm (Thread BSF 9/32 -40)

COLLETS FOR 6.6 MM CAPACITY ANGLE HEAD BHMC-6-6 (-30, -90, -90Z)

| Capacity mm | Ordering No. | Capacity mm | Ordering No. |
|-------------|--------------|-------------|--------------|
| 1.6 | 4110 1411 01 | 4.2 | 4110 1411 14 |
| 1.8 | 4110 1411 02 | 4.4 | 4110 1411 15 |
| 2.0 | 4110 1411 03 | 4.6 | 4110 1411 16 |
| 2.2 | 4110 1411 04 | 4.8 | 4110 1411 17 |
| 2.4 | 4110 1411 05 | 5.0 | 4110 1411 18 |
| 2.6 | 4110 1411 06 | 5.2 | 4110 1411 19 |
| 2.8 | 4110 1411 07 | 5.4 | 4110 1411 20 |
| 3.0 | 4110 1411 08 | 5.6 | 4110 1411 21 |
| 3.2 | 4110 1411 09 | 5.8 | 4110 1411 22 |
| 3.4 | 4110 1411 10 | 6.0 | 4110 1411 23 |
| 3.6 | 4110 1411 11 | 6.2 | 4110 1411 24 |
| 3.8 | 4110 1411 12 | 6.4 | 4110 1411 25 |
| 4.0 | 4110 1411 13 | 6.6 | 4110 1411 26 |

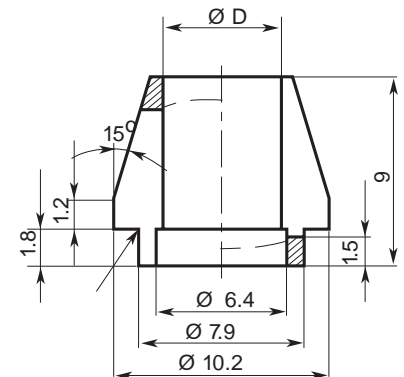

Collets for 6.6 mm

Collet nut 4110 1410 00, to be ordered separately.

COLLETS FOR 8.0 MM CAPACITY ANGLE HEAD BHMC-8-0 (-90)

| Capacity mm | Ordering No. | Capacity mm | Ordering No. |
|-------------|--------------|-------------|--------------|
| 6.8 | 4110 1812 01 | 7.6 | 4110 1812 05 |
| 7.0 | 4110 1812 02 | 7.8 | 4110 1812 06 |
| 7.2 | 4110 1812 03 | 8.0 | 4110 1812 07 |
| 7.4 | 4110 1812 04 | | |

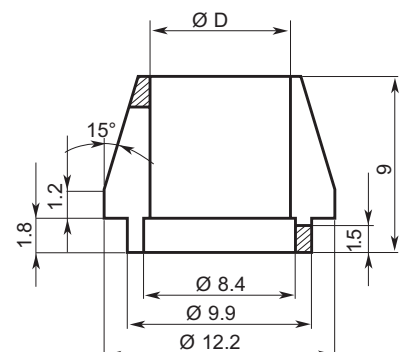

Collets for 8.0 mm



Service Kits

LBD16M 4081 0322 90

LBP16M 4081 0271 90

The Atlas Copco LBS36 drill is equipped with an integrated micro stop. It is designed for the aerospace industry where the focus is on high-precision drilling, reaming and countersinking.

- **Accurate** – The integrated micro stop function makes the LBS36 unique for high-precision drilling of rivet holes and other fasteners. Minimized spindle run-out is achieved by eliminating standard drill chuck.
- **Ergonomic handle design** – The integrated micro stop function makes the tool shorter and lighter in weight.
- **Flexible** – Can be used for drilling, reaming, countersinking and, in certain applications, a combined operation using a form bit.
- **Dust extraction** – Equipped with a specially designed spot suction system for working in composite materials.
- **Lubrication-free** – For clean working environment and operator comfort.



| Model | Free speed r/min | Spindle thread in/mm | Stroke | | Setting range ± | | Weight lb | Hose size | | Air consumption cfm | Air inlet thread NPT | Ordering No. |
|---------------|---------------------|----------------------------|--------|-----|--------------------|-----|--------------|-----------|-----|------------------------|----------------------------|--------------|
| | | | mm | in | mm | in | | mm | in | | | |
| LBS26 H033-40 | 3300 | 1/4"-28 | 40 | 1.6 | 6 | 1/4 | 2.0 | 10 | 3/8 | 31.8 | 3/8 | 8421 0220 40 |
| LBS26 H013-40 | 1300 | 1/4"-28 | 40 | 1.6 | 6 | 1/4 | 2.6 | 10 | 3/8 | 31.8 | 3/8 | 8421 0220 45 |
| LBS36 H033-40 | 3300 | 1/4"-28 | 40 | 1.6 | 6 | 1/4 | 2.6 | 10 | 3/8 | 34.9 | 3/8 | 8421 0220 80 |
| LBS36 H013-40 | 1300 | 1/4"-28 | 40 | 1.6 | 6 | 1/4 | 3.3 | 10 | 3/8 | 34.9 | 3/8 | 8421 0220 90 |

Dimensions

| Model | L mm | H mm | C mm |
|---------------|---------|---------|---------|
| LBS26 H033-40 | 253 | 146 | 21 |
| LBS26 H013-40 | 285 | 146 | 21 |
| LBS36 H033-40 | 281 | 157 | 21 |
| LBS36 H013-40 | 314 | 157 | 21 |

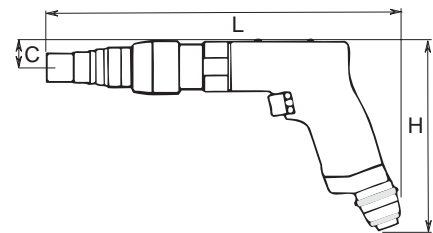

Accessories Included

Hose nipple
2x2 mm Allen wrenches

Optional Accessories

| Designation | | Attachment | Ordering No. |
|--|-------|------------|--------------|
| Plain base, dia 24 mm | Fig 1 | M 20x1 | 4110 1521 00 |
| Plain base for nylon ring (attached with thread M35x1) | Fig 2 | M 20x1 | 4110 1522 00 |
| Separate nylon ring for above base, outer dia 40 mm, thread M35x1 | Fig 3 | M 20x1 | 4110 1523 00 |
| Plain base, dia 14.5 mm | Fig 4 | M 20x1 | 4110 1520 00 |
| Tripod, nylon supported | Fig 5 | Dia 22 mm | 4110 1524 00 |

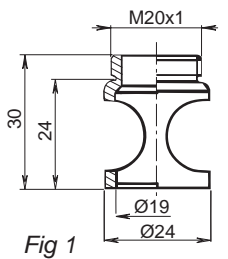

Fig 1

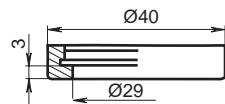

Fig 3

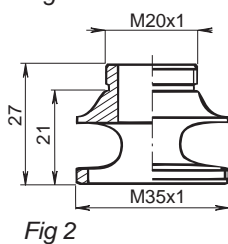

Fig 2

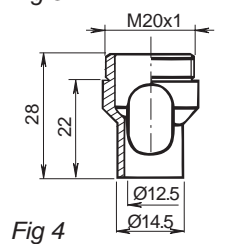

Fig 4

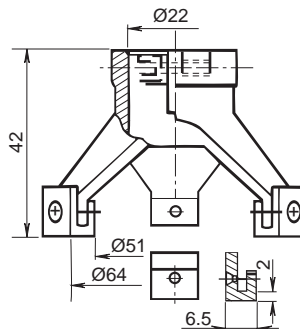

Fig 5



Service Kits

LBS26 4081 0507 90
LBS36 4081 0005 90

Atlas Copco tappers are designed for tapping and thread-cleaning operations with thread taps. The tools are fitted with a tap chuck as standard.

- Comfortable and effective – The ergonomically designed handle gives a comfortable grip and maximum performance.
- Higher productivity – Double speed when you withdraw the machine.
- Low noise level – Rear-directed exhaust gives a lower noise level.
- Lubrication-free – For a clean working environment and operator comfort.
- Quick change system – Upgrade your old tool, or order a new one with this system. Various tap holders can be used to change a broken tap or to change to a different tap size.
- Lower cost – The efficient air motor, together with interchangeable components from our standard drills, cut your costs.



| Model | Free speed | | Tapping capacity mm | Weight | | Hose dimension | | Air inlet thread BSP | Air consumption | | With chuck Ordering No. |
|---|------------------|------------------|------------------------|--------|-----|----------------|-----|-------------------------|-----------------|------|----------------------------|
| | Forward r/min | Reverse r/min | | kg | lb | mm | in | | l/s | cfm | |
| Pistol-grip tappers with air supply through handle | | | | | | | | | | | |
| LGB34 H007 | 700 | 1400 | 10 | 1.8 | 4.0 | 10.0 | 3/8 | 1/4 | 7.5 | 15.9 | 8421 0311 66 |
| LGB34 H007Q ^a | 700 | 1400 | 10 | 1.8 | 4.0 | 10.0 | 3/8 | 1/4 | 7.5 | 15.9 | 8421 0311 76 |
| LGB36 H007Q ^a | 700 | 1400 | 12 | 2.0 | 4.4 | 10.0 | 3/8 | 3/8 | 16.5 | 34.9 | 8421 0411 00 |
| Straight tappers | | | | | | | | | | | |
| LGB34 S007 | 700 | 1400 | 10 | 1.8 | 4.0 | 10.0 | 3/8 | 1/4 | 7.5 | 15.9 | 8421 0311 72 |

^a Quick change system.

Taper: Jacob 1

Dimensions

| Model | L mm | H mm | C mm |
|------------|---------|---------|---------|
| LGB34 H007 | 300 | 156 | 20 |
| LGB34 S007 | 293 | 43 | 21 |
| LGB36 H007 | 335 | 157 | 20 |

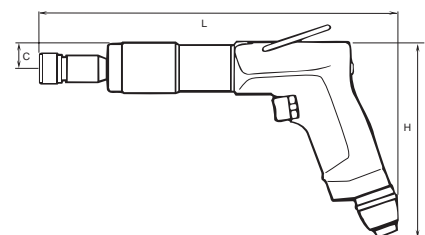

Accessories Included

Non Quick change system

LGB34 Chuck complete with collet 6.4-10 mm 4021 0469 00

Quick change system

Chuck plus one tap holder with collet for M6 shank Ø 6.3 mm.

Optional Accessories

COLLETS FOR NON QUICK CHANGE SYSTEM

| Model | Capacity | | Ordering No. |
|-------|-----------|---------------|--------------|
| | mm | inch | |
| LGB34 | 3.5 - 6.5 | 0.139 - 0.257 | 4021 0337 00 |
| | 4.5 - 8.1 | 0.176 - 0.320 | 4021 0336 00 |
| | 6.4 - 9.7 | 0.253 - 0.383 | 4021 0456 00 |

COLLETS FOR QUICK CHANGE SYSTEM

| Collets for tap size mm | Shank dia | | Ordering No. |
|----------------------------|-----------|-------------|--------------|
| | mm | in | |
| M2.2/M2.5 | 2.8 | | 4021 0414 01 |
| M3 | 3.15 | 1/8 | 4021 0414 02 |
| M3.5 | 3.5 | | 4021 0414 03 |
| M4 | 4.0 | | 4021 0414 04 |
| M4.5 | 4.5 | | 4021 0414 05 |
| M5 | 5.0 | 3/16 | 4021 0414 06 |
| M5.5 | 5.6 | 7/32 | 4021 0414 07 |
| M6 | 6.4 | 1/4 | 4021 0414 08 |
| M6 (DIN) | 6.0 | | 4021 0414 13 |
| M7 | 7.1 | 9/32 | 4021 0414 09 |
| M8/M11 | 8.0 | 5/16 & 7/16 | 4021 0414 10 |
| M9/M12 | 9.0 | 1/2 | 4021 0414 11 |
| M10 | 10.0 | 3/8 | 4021 0414 12 |

COMPLETING EXISTING EQUIPMENT WITH QUICK CHANGE SYSTEM

| Accessories | Length mm | Ordering No. |
|--------------------|--------------|--------------|
| Quick change chuck | 47 | 4021 0406 90 |
| Tap holder | 58 | 4021 0408 00 |



Service Kits

| | |
|-------|--------------|
| LGB34 | 4081 0035 90 |
| LGB36 | 4081 0194 90 |

Atlas Copco screw-feed drills are ideal for heavy-duty drilling operations requiring high feed forces. They can also be used for reaming and tube-rolling.

- **Reliable** – Simple, reliable design.
- **Constant speed** – The speed governor keeps the drilling speed constant and reduces air consumption as power is reduced.
- **Safer** – The safety catch prevents accidental starting. The throttle is also self-closing.



| Model | Forward | Reverse |
|-------|---------|---------|
| RAB9 | 1.14 hp | 0.74 hp |
| RAB12 | 2.0 hp | 1.5 hp |

| Model | Free speed r/min | Capacity | | | Morse taper No. | Length feed mm | Height in | Weight lb | Hose dimension | | Air consumption max output cfm | Distance centre to side mm | Air inlet thread NPT | Ordering No. |
|------------|------------------|-------------|------------|------------|-----------------|----------------|-----------|-----------|----------------|-----|--------------------------------|----------------------------|----------------------|--------------|
| | | Drilling mm | Reaming mm | Tapping mm | | | | | mm | in | | | | |
| RAB9 VR003 | 300 | 23 | 23 | 16 | 2 | 75 | 10.4 | 20.9 | 13 | 1/2 | 47 | 40 | 1/2 | 8421 5109 37 |
| RAB9 VR006 | 600 | 23 | 23 | 12 | 2 | 75 | 10.4 | 20.9 | 13 | 1/2 | 49 | 40 | 1/2 | 8421 5109 45 |
| RAB12 L150 | 140 | 51 | 40 | 32 | 4 | 90 | 15.2 | 32.8 | 16 | 5/8 | 64 | 50 | 1/2 | 8421 5112 08 |
| RAB12 L250 | 240 | 51 | 40 | 30 | 4 | 90 | 13.2 | 32.8 | 16 | 5/8 | 70 | 50 | 1/2 | 8421 5112 16 |
| RAB12 L450 | 475 | 32 | 32 | 24 | 3 | 90 | 13.4 | 28.4 | 16 | 5/8 | 68 | 50 | 1/2 | 8421 5112 24 |

Accessories Included

Hose nipple

Optional Accessories

SQUARE DRIVE ADAPTER

| Morse taper No. | Square drive in | Ordering No. |
|-----------------|-----------------|--------------|
| 3 | 1 | 4021 0394 00 |
| 4 | 1 | 4021 0395 00 |



Square drive adapter

Robust and versatile, the PFD-drills are your best choice for holemaking

PRODUCTIVITY

With this platform you have all you need for hole preparation. Reduce cycle time and increase output with a powerful turbine motor. This robust tool is well suited for factory environment and the long service intervals maximizes uptime of your investments.

HOLE QUALITY

Keep your workplace clean with Atlas Copco's ChipLet® feature which makes chips easy to evacuate. With ChipLet® during countersinking, you have a one-step process. Giving process improvements in terms of both productivity and quality.

ERGONOMICS

My operators will really appreciate how all the controls on the tool are grouped in one and the same place. This reduces the risk of operator errors. The tool is also very well balanced which makes it easy to move around.

SAFE OPERATION

The modular design means fewer back-up tools. You can also save on service as the platform is based on standard, reusable components.

SUPPORT

The modular approach means quick deliveries when needed, and makes it easy to re-work your existing products when urgent applications come up. With our technical documentation and support you will quickly put new tools to work on your assembly line.

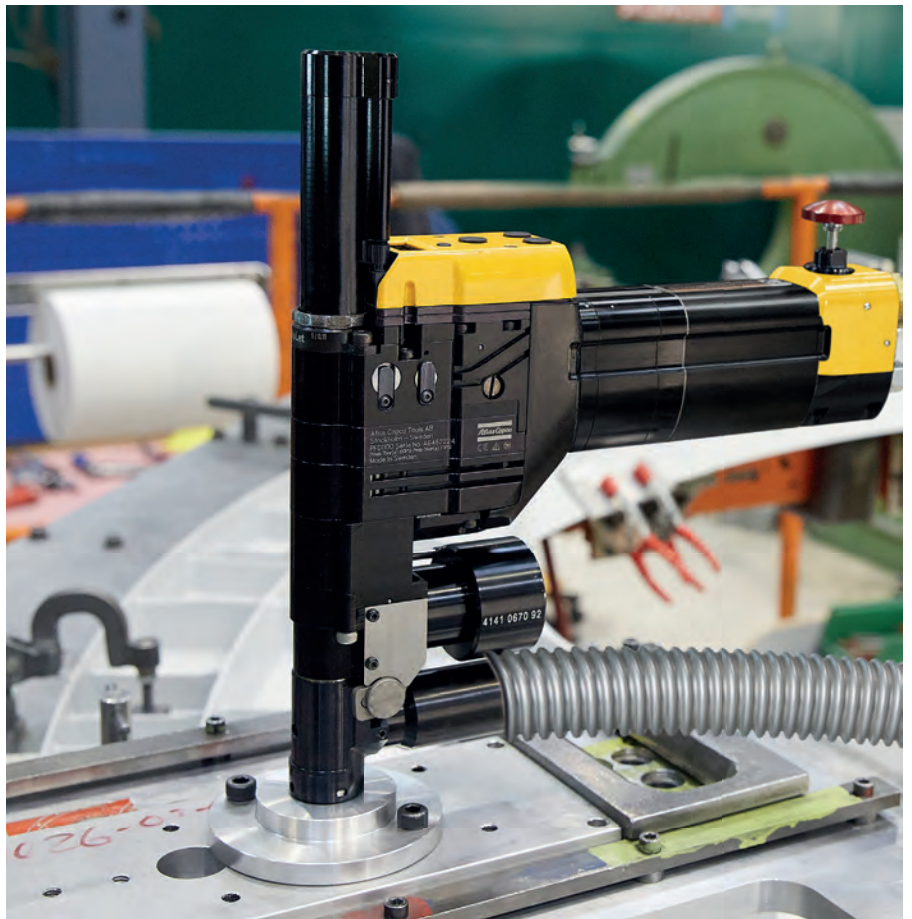

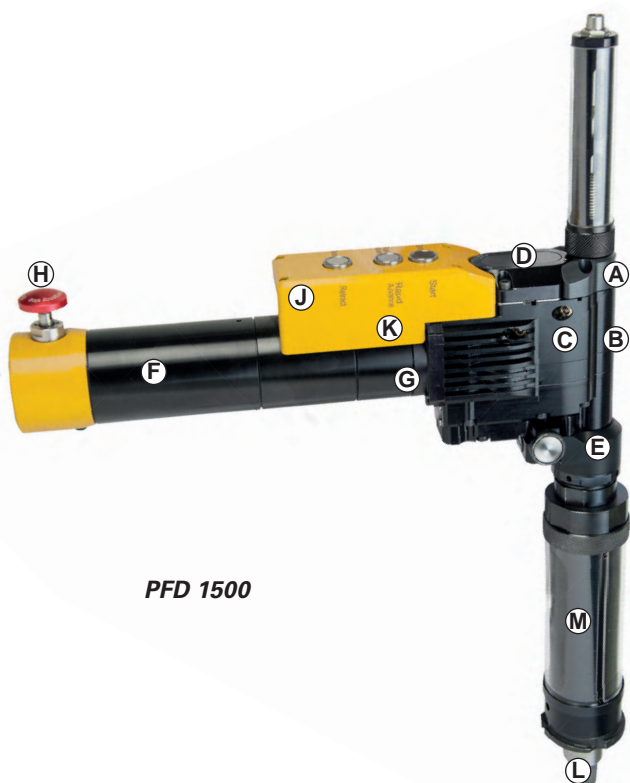

PFD 1500

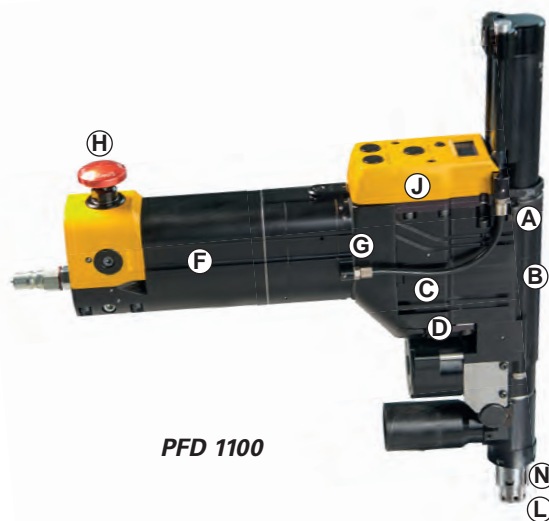

PFD 1100

PFD 1500

| Item | Ordering No. |
|---------------------|--------------|
| PFD1500RA-200-R | 8440 1500 39 |
| Indexer-1-9-16 | 4141 0306 90 |
| PFD1500-IPR2 | 4141 0034 92 |
| Spindle-1500-12-9-6 | 4141 0004 91 |
| Guard-1500-12 | 4141 0323 91 |
| Nose-8IN-1-1-2 | 4141 0245 90 |

Example: Twistlock model with rapid advance and indexer. Spindle with 9/16"-18" interface, speed of 200 rpm and feed of 0.05 mm/r (0.002 IPR). Suitable for drilling of 19 mm holes (3/4") in Ti or Ti/CFRP stacks.

PFD 1100

| Item | Ordering No. |
|--------------------|--------------|
| PFD1100RA-IFB110B | 8440 1110 66 |
| Spindle-CC-1100-2 | 4141 0742 90 |
| Guard-1100-2in-p | 4141 0826 92 |
| Guide-CC-R-1100-M6 | 4141 0743 91 |
| Bush-CC-1100-53 | 4141 0707 92 |
| Foot-CC-1100-MINI | 4141 0764 90 |
| Mandrel-CC-25.4-A | 4141 0806 28 |
| Collet-CC-1 | 4141 0813 28 |

Example: Concentric collet model with inboard lubricator, counter and ChipLet®. Spindle with M6 interface, speed of 2600 rpm and feed of 0.07 mm/r (0.003 IPR). Suitable for drill and countersink of Ø 6.35 (1/4") holes in Al or Al/CFRP stacks.

- (A) Optional ChipLet® module which effectively breaks chips while drilling for improved chip evacuation and hole quality.
- (B) Angle head with superior durability with double needle bearings for both feed and drive gear.
- (C) Overload clutch protects the angle head and drive train from overthrust.
- (D) The replaceable feed cassette system enables quick and easy change of feed rate.
- (E) Optional indexer which allows the tool to be locked in the jig also when free space is compromised.
- (F) High torque, high power governed air motor maintains cutting speed while drilling.
- (G) Easy-to-change split gearbox for quick adjustment of rpm.
- (H) Emergency stop fully compliant with the European machinery directive for a high level of safety.
- (J) Rapid advance of spindle reduces cycle time and makes setup a quick and safe task.
- (K) Reliable and user-friendly tool controls with optional cycle counter.
- (L) Best in class spindle power and thrust capabilities. A wide range of speeds and feeds.
- (M) A large selection of tool noses with or without vacuum port makes the tool fit existing drill jigs.
- (N) Concentric collet foot which allows clamp force for countersinking up to diameter 22 mm (7/8"). Debris protection and efficient vacuum exhaust of chips. Foot is modular and easily removed for drill bit change.

Specifications

| Feature | PFD1100 | | PFD1500 | |
|----------------------|-------------|------------|-------------|------------|
| | Metric | Imperial | Metric | Imperial |
| Motor | Turbine | Turbine | Vane | Vane |
| Drill and ream | yes | yes | yes | yes |
| Countersinking | yes | yes | no | no |
| Sound level | 78 dB(A) | 78 dB(A) | 83 dB(A) | 83 dB(A) |
| Spindle power | 1.7 kW | 2.3 hp | 1.5 kW | 2.0 hp |
| Max hole | 15.9 mm | 5/8" | 32 mm | 1 1/4" |
| Max countersink | 22 mm | 7/8" | N/A | N/A |
| Max speed | 7300 rpm | 7300 rpm | 2360 rpm | 2360 rpm |
| Min speed | 350 rpm | 350 rpm | 38 rpm | 38 rpm |
| Max thrust | 2000 N | 450 lbf | 4000 N | 900 lbf |
| Max clamp force (cc) | 1800 N | 400 lbf | N/A | N/A |
| Max feed | 0.17 mm/rev | 0.007 IPR | 0.25 mm/rev | 0.010 IPR |
| Tool weight (base) | 3.0 kg | 6.6 lb | 5.5 kg | 12.0 lb |
| Max air consumption | 30 l/s | 60 cfm | 35 l/s | 70 cfm |
| Air inlet | 1/2" BSP | 1/2" NPT | 1/2" BSP | 1/2" NPT |
| Operating pressure | 5.5–7.5 bar | 80-110 psi | 5.5–7.5 bar | 80-110 psi |
| Angle head radius | 16.0 mm | 5/8" | 17.8 mm | 0.7" |
| Air hose | 13 mm | 1/2" | 16 mm | 5/8" |

Collet



Mandrel



Counter sink stop nut



Optional Equipment

| Item | PFD1100 | PFD1500 |
|---------------------------|----------------|---------------------|
| Chiptlet® | yes | yes |
| Rapid advance | no | yes (with J-Clutch) |
| Lubrication pump | inboard, 30 ml | onboard, 55 ml |
| Counter | yes | yes |
| Indexer | yes | yes |
| Tool handle | no | yes |
| Nose sizes | 21k–23k | 23k–25k |
| Concentric collet | yes | no |
| Max collet outer diameter | 1 3/8" | N/A |

Tool nose with vacuum port



Tool nose



Tool nose indexer



Concentric collet unit



Air Installation

| Item | PFD1100 Light to Medium Duty Cycle | PFD1500 / PFD1100 Heavy Duty Cycle |
|----------------------|---------------------------------------|---------------------------------------|
| Swivel | MultiFlex with 1/2 | MultiFlex with 1/2 |
| Coupling | ErgoQIC 08 with H13 | ErgoQIC 10 with H16 |
| Air fitting | ErgoNIP 08 with 1/2 | ErgoNIP 10 with 1/2 |
| Hose | PVC 13, 30 m coil | PVC 16, 30 m coil |
| Clamp | clamp for PVC 13 | clamp for PVC 13 |
| Air preparation unit | MIDI Optimizer F/R A with 1/2 | Optimizer F/R A with 1/2 |
| Ball valve | BAL-1A with 1/2 | BAL-1A with 1/2 |
| Connection | Double with two 1/2 | Double with two 1/2 |

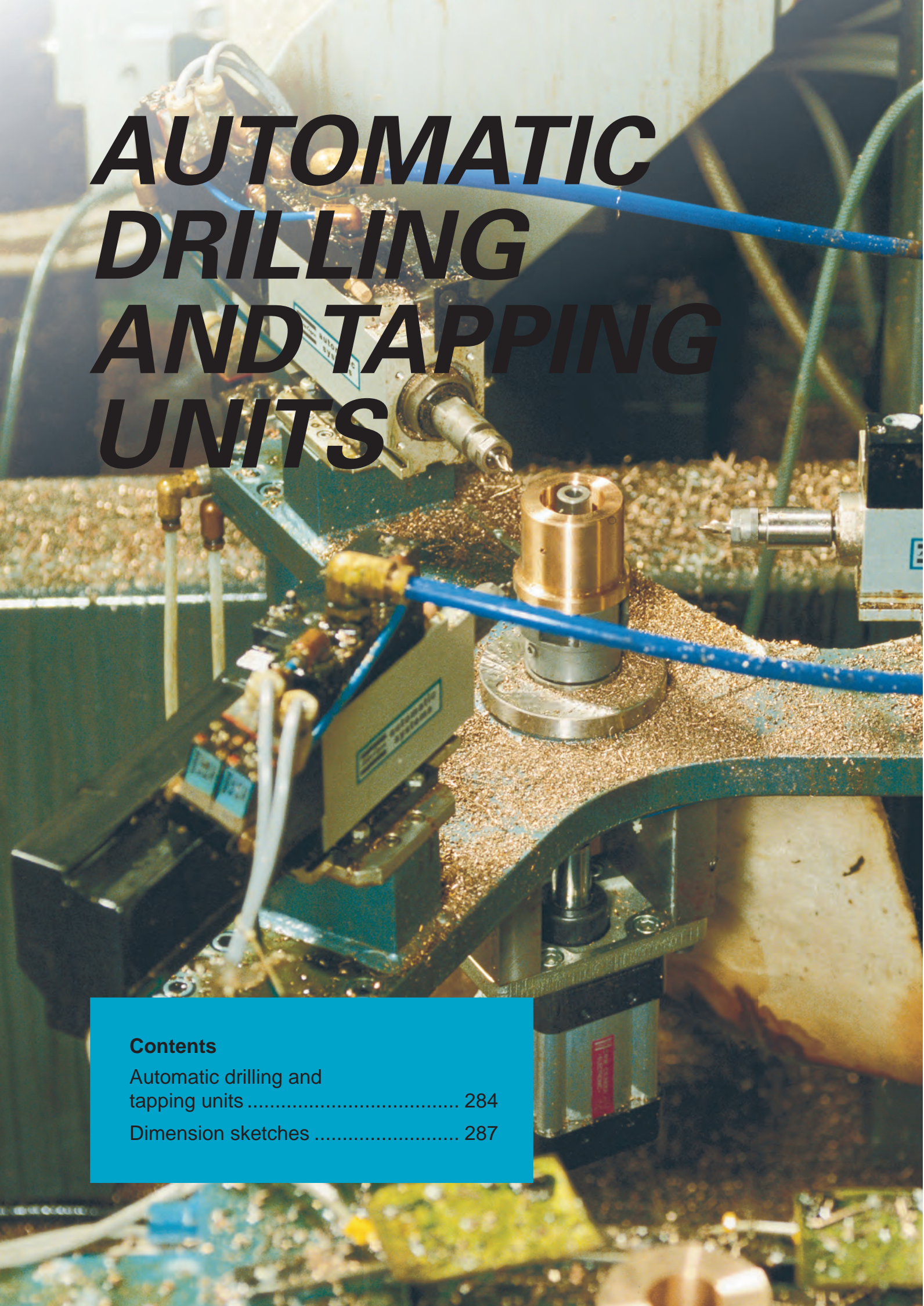
A close-up photograph of an industrial automatic drilling and tapping unit. The machine is a complex assembly of metal parts, including a drill bit, a tapping tool, and various sensors and actuators. A blue cable is connected to the machine. The background is a blurred industrial setting with other machinery and pipes.

AUTOMATIC DRILLING AND TAPPING UNITS

Contents

| | |
|--|-----|
| Automatic drilling and tapping units | 284 |
| Dimension sketches | 287 |

More mechanization in your drilling operations

Simple and cost effective, Atlas Copco automatic drilling and tapping units cut costs by reducing machining time in ancillary equipment, or in highly automated special machines. Modular designs allow the units to be easily replaced, transferred to other machines, or combined to form new special-purpose machines.



Selection Guide

Dimensions in mm



Steel



Aluminum

LBL45

| 025 | 015 | 010 | 007 | 003 |
|------|------|------|------------|------------|
| — | 7.0 | 10.0 | 14.0 (M8) | 20.0 (M12) |
| | | | | |
| | | | | |
| 10.0 | 14.0 | 16.0 | 22.0 (M12) | 32.0 (M16) |

LBL35

| 054 | 030 | 014 | 007 |
|-----|-----|-----------|------------|
| 3.0 | 5.0 | 8.0 (M4) | 11.0 (M8) |
| | | | |
| | | | |
| 5.0 | 7.0 | 10.0 (M5) | 13.0 (M10) |

LBL25

| 220 | 049 | 022 | 011 |
|-----|-----|-----|------|
| 1.2 | 3.2 | 5.0 | 8.0 |
| | | | |
| | | | |
| 2.0 | 5.0 | 6.5 | 10.0 |

These units are available in three sizes, LBL25, LBL35 and LBL45, each size covering a specific diameter range, totally up to 32 mm in aluminium.

The basic units can be fitted with different chucks, twin heads for simultaneous drilling of two holes and attachments for chip removal and tapping.

- **Highly dependable** – LBL drilling and tapping units feature quick and precise clamping, making them highly dependable.
- **Easy to build together** – Several holes can be drilled in a single operation since several of these compact units can easily be built together.
- **Low noise level** – The units have a low noise level as the exhaust air is discharged through silencers inside the protective casing.



| Model | Capacity | | Feed force N | Max output | | Feed stroke mm | Free speed r/min | Weight | | Air consumption | | | | Ordering No. |
|------------|-------------------|---------------------|-----------------|------------|-----|-------------------|---------------------|--------|------|-----------------|-----|------------|-----|--------------|
| | Steel mm | Alumi- num mm | | kW | hp | | | kg | lb | Max output | | Free speed | | |
| | | | | | | | | | | l/s | cfm | l/s | cfm | |
| LBL25E 049 | 3.2 | 5.0 | 350 | 0.22 | 0.3 | 80 | 4600 | 3 | 6.6 | 5.2 | 11 | 5.8 | 12 | 8421 9208 55 |
| LBL25E 022 | 5.0 | 6.5 | 350 | 0.22 | 0.3 | 80 | 2100 | 3 | 6.6 | 5.2 | 11 | 5.8 | 12 | 8421 9208 63 |
| LBL25E 011 | 8.0 | 10.0 | 350 | 0.22 | 0.3 | 80 | 1100 | 3 | 6.6 | 5.2 | 11 | 5.8 | 12 | 8421 9208 71 |
| LBL35E 007 | 11.0 ^c | 13.0 ^d | 1050 | 0.33 | 0.5 | 80 | 700 | 7 | 15.0 | 9.5 | 21 | 10.6 | 22 | 8421 9308 04 |
| LBL35E 014 | 8.0 ^a | 10.0 ^b | 1050 | 0.33 | 0.5 | 80 | 1400 | 7 | 15.0 | 9.5 | 21 | 10.6 | 22 | 8421 9308 12 |
| LBL35E 030 | 5.0 | 7.0 | 1050 | 0.33 | 0.5 | 80 | 3000 | 7 | 15.0 | 9.5 | 21 | 10.6 | 22 | 8421 9308 38 |
| LBL35E 054 | 3.0 | 5.0 | 1050 | 0.33 | 0.5 | 80 | 5400 | 7 | 15.0 | 9.5 | 21 | 10.6 | 22 | 8421 9308 46 |
| LBL45E 003 | 20.0 ^e | 32.0 ^f | 2500 | 0.80 | 1.1 | 120 | 320 | 16 | 35.0 | 20.0 | 44 | 9.0 | 19 | 8421 9408 03 |
| LBL45E 007 | 14.0 ^c | 22.0 ^d | 2500 | 0.80 | 1.1 | 120 | 700 | 16 | 35.0 | 20.0 | 44 | 9.0 | 19 | 8421 9408 29 |
| LBL45E 010 | 10.0 | 16.0 | 2500 | 0.80 | 1.1 | 120 | 1000 | 16 | 35.0 | 20.0 | 44 | 9.0 | 19 | 8421 9408 37 |
| LBL45E 025 | - | 10.0 | 2500 | 0.80 | 1.1 | 120 | 2500 | 16 | 35.0 | 20.0 | 44 | 9.0 | 19 | 8421 9408 52 |

Recommended max tapping size: ^aM4 ^bM5 ^cM8 ^dM10 ^eM12 ^fM16

Optional Accessories**LBL25**

| Designation | Ordering No. |
|---|--------------|
| Hydraulic damper (feed stroke 65 mm) | 4130 1844 80 |
| Key chuck (0-6.5 mm) | 4021 0283 00 |
| Key chuck (2-10 mm) | 4021 0416 00 |

*Hydraulic damper***LBL35**

| Designation | Ordering No. |
|---|--------------|
| Hydraulic damper (feed stroke 65 mm) | 4130 1844 80 |
| Key chuck (2.0-13.0 mm) | 4021 0452 00 |
| Sleeve chuck (2.0-9.5 mm) | 4021 0459 00 |
| Twin spindle head, speed ratio 1:1, center to center adjustment range 12.7-63.5 mm | 4130 1363 84 |
| Other multiple heads on request | |
| Tapping unit, M2-M7 SPD3, Taper socket J33 | 4130 1938 00 |
| Holder for tapping unit SPD3 | 4130 1787 00 |
| Collet 2.5-5 mm | 4021 0412 00 |
| Collet 5-6.3 mm | 4021 0413 00 |
| Tapping unit, M3-M12 SPD5, Tapping Socket J33 | 4130 1939 00 |
| Holder for tapping unit SPD5 | 4130 1860 00 |
| Collet 3.3-6.8 mm | 4021 0337 00 |
| Collet 4.5-8.7 mm | 4021 0336 00 |
| Collet 6-10 mm | 4021 0456 00 |

*Key chuck**Sleeve chuck**Morse taper socket***LBL45**

| Designation | Ordering No. |
|--|--------------|
| Hydraulic damper (feed stroke 110 mm) | 4130 1895 80 |
| Key chuck (3.2-16.0 mm) | 4021 0423 00 |
| Sleeve chuck (2.0-9.5 mm) | 4021 0458 00 |
| No. 2 Morse taper socket | 4130 1080 00 |
| No. 3 Morse taper socket | 4130 1079 00 |
| Twin spindle head, speed ratio 1:1, center to center adjustment range 19-95 mm | 4130 1364 82 |
| Other multiple heads on request | |
| Tapping unit, M15-M18 SPD7, Taper socket, J3 | 4130 1940 00 |

*Tapping unit**Twin spindle head*

Optional Accessories

PROGRAMMED DAMPING DEVICE

| Model | Ordering No. |
|------------|--------------|
| LBL35, -45 | 4130 1961 80 |

To be used together with the hydraulic damper.

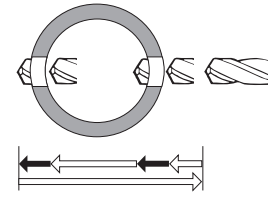

Programmed damping device

COLLETS FOR SLEEVE CHUCK LBL35/45 TWIN HEAD LBL45

| Size mm | Ordering No. |
|---------|--------------|
| 5.0 | 4130 1561 30 |
| 5.5 | 35 |
| 6.4 | 44 |
| 6.5 | 45 |
| 7.0 | 4130 1561 50 |
| 8.0 | 4130 1561 60 |
| 8.5 | 65 |
| 9.0 | 4130 1561 70 |
| 9.5 | 75 |

COLLETS FOR TWIN HEAD LBL35

| Size mm | Ordering No. |
|---------|--------------|
| 3.2 | 4130 1367 22 |
| 4.0 | 4130 1367 30 |
| 6.5 | 4130 1367 55 |

MOUNTINGS

| Ref. No. | Designation | Ordering No. | |
|----------|-------------|---------------------------|---------------------------|
| | | LBL25, LBL35 | LBL45 |
| 1 | Base plate | 4140 0077 80 | 4140 0081 80 |
| 2 | Base plate | 4140 0080 80 | 4140 0084 80 |
| 8 | Locking bar | 4140 0078 00 ^a | 4140 0082 00 ^a |

^a Two per unit.

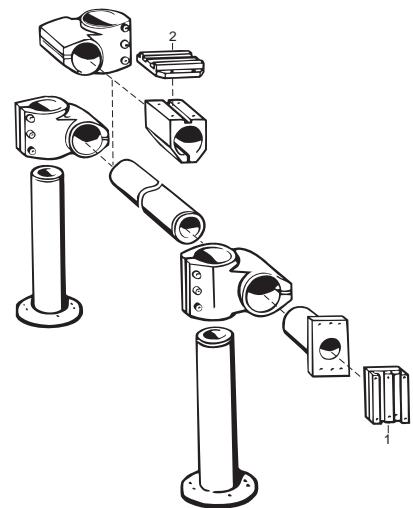

Dimensions

DIMENSION SKETCH - LBL25

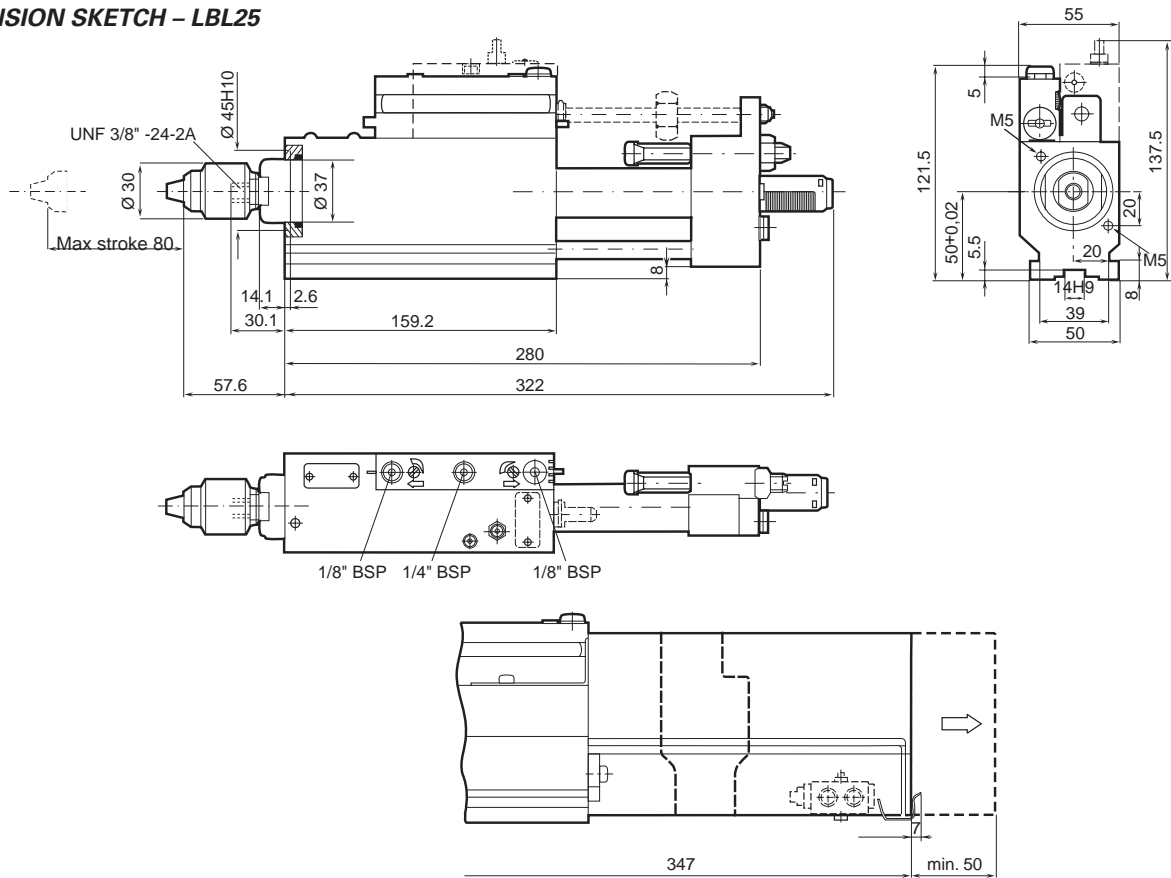

DIMENSION SKETCH - LBL35

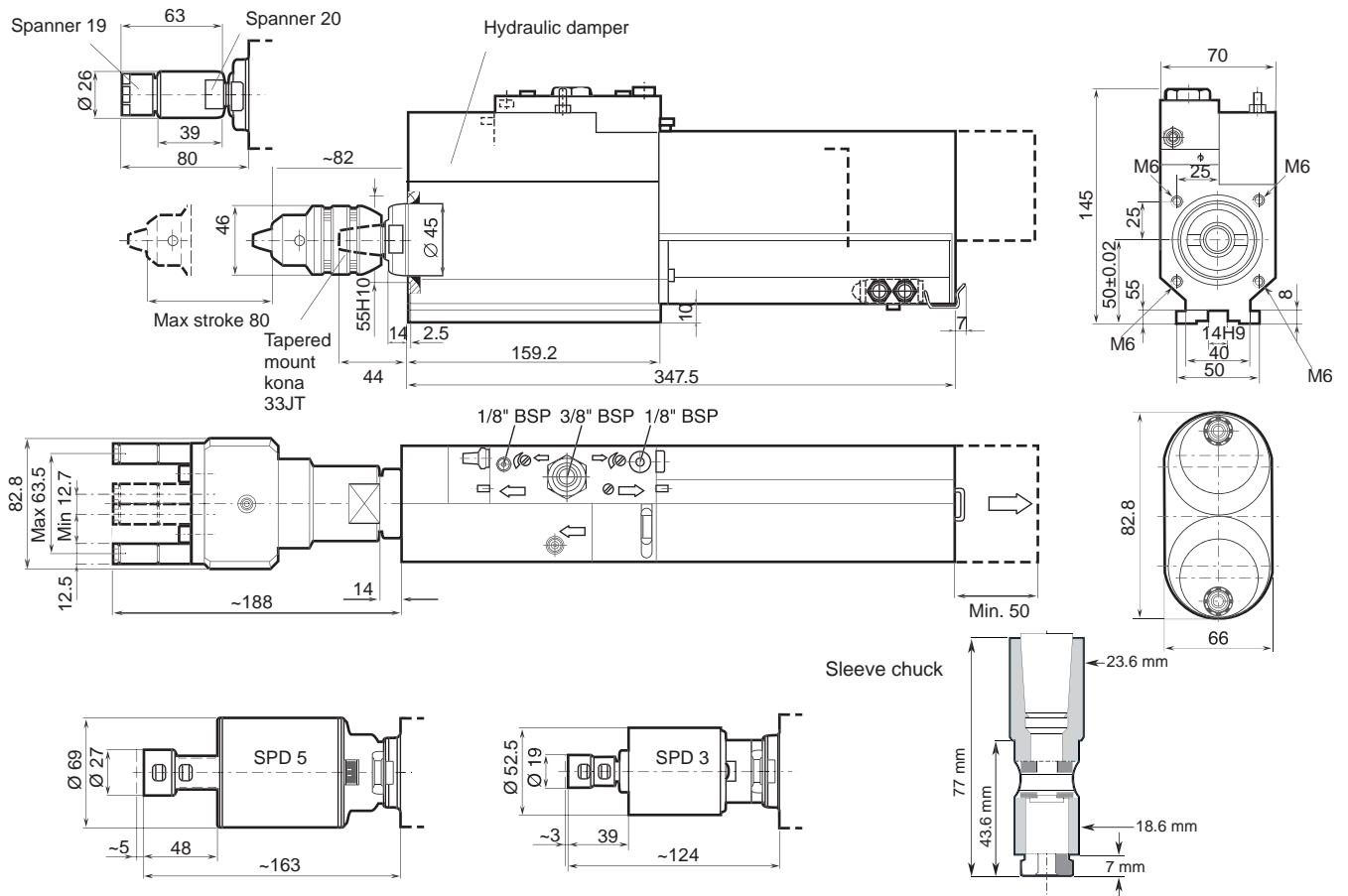

DIMENSION SKETCH – MOUNTINGS FOR LBL45E

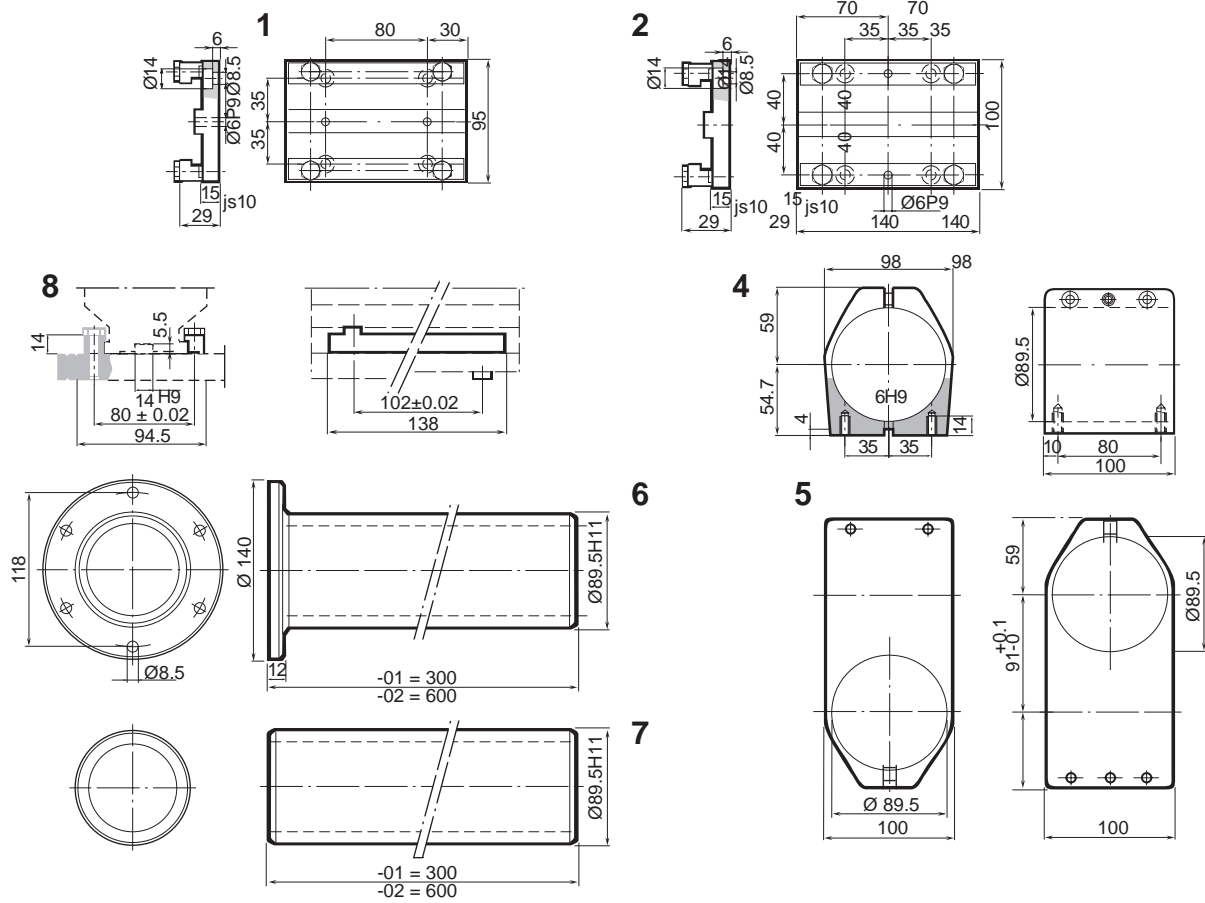

AIR LINE ACCESSORIES



Contents

| | | | |
|-----------------------------|-----|----------------------------|-----|
| Introduction..... | 291 | Hoses | 310 |
| Product safety..... | 292 | Spiral hoses..... | 315 |
| Air preparation units | 293 | Productivity kits..... | 316 |
| Optimizer air tool oil..... | 297 | Pre-mounted hose kits..... | 317 |
| Quick couplings | 298 | Hose reels | 318 |
| Claw couplings | 306 | Balancers..... | 322 |
| Ball valves | 307 | Blow gun..... | 325 |
| Swivel connectors..... | 308 | Test equipment | 325 |
| Fittings | 309 | | |

Ensure that your tools achieve their full potential

To ensure that you benefit from the full potential power of your tools, Atlas Copco has developed a full range of air line accessories for use with Atlas Copco tools and air motors. All accessories can be used for other applications and pneumatic equipment.

PRODUCTIVITY

By using Atlas Copco's air line accessories you ensure that you have a correct air line installation for your tool. This will provide the correct air flow to the tool, ensuring that you benefit from its full potential power, and that you reach the correct torque in torque-controlled tools. By using the recommended accessories you will also minimize the service requirements of the tool.

ENERGY EFFICIENCY

With a correct installation you will not only achieve the tool's full potential power, you will also reduce energy costs. All Atlas Copco accessories are designed for minimum pressure drop, which ensures that the compressor is not "working overtime".

SAFETY

All accessories are designed to meet the highest demands for a safe working environment. Atlas Copco has developed a wide range of safety couplings, balancers and hose reels to meet today's high standards in terms of workplace safety.

ERGONOMICS

Operator health and well-being are important factors. Atlas Copco accessories, such as torque arms, balancers, screw presenters and reaction bars, enable you to configure ergonomically correct workstations for your operators.

QUALITY

All Atlas Copco accessories are made of the highest quality materials for long production cycles and to withstand rough treatment. Choose Atlas Copco accessories and you will be sure of high quality products.



Product Safety

All local safety regulations with respect to installation, operation and overhaul must always be followed. Please read the separate instructions regarding safety which are supplied with all products in order to improve your own safety!

BALL VALVE

- Switch off the compressed air with the ball valve when you are not working (see fig. 1).
- Open all ball valves gently in order to discover improperly tightened devices (see fig. 5).

AIR PREPARATION UNITS

- Please check for solvents which change the structure of polycarbonate^a bowls.

These solvents make the polycarbonate brittle so it can break. Normally polycarbonate is not easy to break. If you need to use aggressive solvents, please contact us and we will help you choose the right equipment.

- Use bowl guard.

An easy way to eliminate this type of accident is to use a bowl guard on MINI and MIDI units. The MAXI unit has an aluminum bowl with a new, more chemical resistant plastic on the inside as standard.

Check that the bowls are properly tightened and that all units are fitted together before switching on the compressed air with the ball valve.

QUICK SAFETY COUPLINGS

To increase the safety and reduce the risk of operator injuries we recommend you to always buy couplings with a safety function. Couplings with a safety function are disconnected in two stages in order to vent the coupling and minimize the risk

of sudden component separation, which has the potential to cause operator injury.

Never open a quick coupling with a screwdriver in order to ventilate the air.

CLAW COUPLINGS

- Be very careful (see fig. 1+2+3).

They are always open and must be used very carefully. To increase safety when using claw couplings, we recommend the claw LNH claw coupling with a lock nut.

CLAMPS AND CONNECTIONS

- Avoid screwdrivers when tightening.

Check that they are properly tightened. Avoid screwdrivers when tightening, they can easily slip and damage your hand. Use a wrench. If you need to use a screwdriver, mount the clamp in a vice.

HOSES

When mounting hoses on hose connections, use water and soap in order to make the hose slip on to the connection.

Do not use oil. Water and soap will dry up. Remove leaking hoses. A small leakage can quickly become a large hole.

BLOW GUNS

- Use the safety version. It eliminates the risk of air at high pressure coming into direct contact with skin.

^a Polycarbonate has good chemical resistance to all solvents except chemicals containing acetone, benzol, glycerine, some hydraulic and synthetic oils, chloroform, methyl alcohol, carbon tetrachloride (and similar solvents), carbon disulphide, perchloroethylene, toluene, trichloroethylene, xylene (nitrocellulose, thinner), acetic acid.

FOLLOW THIS ORDER WHEN WORKING WITH CLAW COUPLINGS.

How to open a claw coupling:

- 1 Close the ball valve.



- 2 Run the tool so the air ventilates out.



- 3 Release the claw coupling.

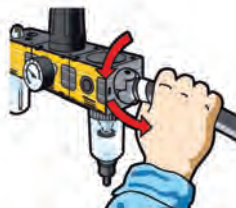

How to close a claw coupling:

- 4 Make sure that the two claw couplings are mounted together.

Use claw couplings with lock nut (LNH) or use a lock spring for safer locking.



- 5 Open the ball valve gently.



Get maximum productivity from your tools

Atlas Copco air preparation units are designed to help you get maximum productivity from your tools. They ensure minimal pressure drop and thus minimum energy losses in the air distribution system, benefiting the environment and cutting your operating costs. The lifetimes of your tools will be extended by using air preparation units and with that comes lower repair costs and less downtime.

A correct air installation ensures productivity and good total economy.

FILTER – FIL

Water and dirt in your compressed air system will cause extensive corrosion damage and wear.

PRODUCTIVITY

Atlas Copco filters are equipped with a cyclone system. Using centrifugal force, this separates out a high percentage of the heavier solid water particles, while the filter ensures that the amount of dirt entering your tool is kept to a minimum. This means longer working cycles for the tools and minimum service time.

REGULATOR– REG

Atlas Copco regulators ensure optimal flow at the specific flow rates required by Atlas Copco tools, or any other pneumatic tools.

ENERGY EFFICIENCY

By installing a regulator you will ensure that there will not be any unnecessary consumption of compressed air. The regulators reduce a variable primary pressure to a practically constant secondary pressure with a minimum of pressure drop.

PRODUCTIVITY

The regulator will optimize the performance of your tool, ensure torque accuracy and boost productivity.

LUBRICATOR – DIM

Atlas Copco oil lubricators ensure a long, efficient and trouble-free life for your pneumatic tools and components.

PRODUCTIVITY

The use of a lubricator will increase the power in vane motors by about 10-15%.

ENERGY EFFICIENCY

With the use of a lubricator you will prolong the lifetime of a vane motor up to three times and the motor will work much more efficiently, and with less friction.



Filter – FIL



Regulator – REG



Lubricator – DIM

The MIDI Optimizer is suitable for more than 90% of the Atlas Copco tool range and is the best choice for assembly tools, percussive tools, drills, nibblers and grinders up to Turbo. The MIDI Optimizer has a 1/2" NPT connection thread and a housing and bowl of high-tech polymer. The bowl has a highly chemical resistant polypropylene insert and the bowl is directly screwed to the housing for easy handling.

MIDI OPTIMIZER SELF-REGULATING NANO-LUBRICATOR

Adjusts automatically to the flow demand and ensures that the right amount of oil is supplied to the motor at all flow rates. This minimizes the lubrication needed. The nano oil mist, with a particle size of 200 nm, can be transported by the air stream up to 130 ft. This means there is no oil in the hose and direct lubrication is not necessary. The lubricator can be refilled during operation. EP-versions are adjusted for use with impulse tools.



WORKING TEMPERATURE

-40°F to +140°F at 145 psi
 +35°F to +140°F at 145 psi for filters
NOTE: For dry compressed air, ice formation must be avoided.

OPERATING PRESSURE

Inlet pressure 0-232 psi
 Outlet pressure 7-116 psi

STANDARD FILTER

30 µm

PRESSURE GAUGE

1/4" BSP
 Included in F/RD and FRD units

| Model | Economical air flow cfm | Maximum air flow cfm | Bowl material | Filter condensate drainage | Max condensate capacity oz | Max oil capacity oz | Weight lb | Ordering No. |
|------------------------------------|-------------------------|----------------------|-------------------------|----------------------------|----------------------------|---------------------|-----------|--------------|
| Filters | | | | | | | | |
| MIDI Optimizer FIL M/S | - | 248 | Polymer, plastic insert | Manual/semi auto | 2 | - | 0.66 | 9093 0021 04 |
| MIDI Optimizer FIL A | - | 248 | Polymer, plastic insert | Automatic | 2 | - | 0.66 | 9093 0021 03 |
| Regulators | | | | | | | | |
| MIDI Optimizer REG | - | 206 | - | - | - | - | 0.77 | 9093 0021 07 |
| MIDI Optimizer REG LP | - | 206 | - | - | - | - | 0.77 | 9093 0021 08 |
| Lubricators | | | | | | | | |
| MIDI Optimizer DIM | 66 | 254 | Polymer, plastic insert | - | - | 3 | 0.66 | 9093 0021 11 |
| Filter/regulator | | | | | | | | |
| MIDI Optimizer F/R M/S | - | 190 | Polymer, plastic insert | Manual/semi auto | 2 | - | 1.1 | 9093 0021 15 |
| MIDI Optimizer F/R A | - | 190 | Polymer, plastic insert | Automatic | 2 | - | 1.1 | 9093 0021 14 |
| Filter/regulator+lubricator | | | | | | | | |
| MIDI Optimizer F/RD A | 66 | 116 | Polymer, plastic insert | Automatic | 2 | 3 | 2.2 | 9093 0021 18 |
| MIDI Optimizer F/RD M/S | 66 | 116 | Polymer, plastic insert | Manual/semi auto | 2 | 3 | 2.2 | 9093 0021 19 |
| MIDI Optimizer F/RD A EP | 66 | 116 | Polymer, plastic insert | Automatic | 2 | 3 | 2.2 | 9093 0021 37 |
| MIDI Optimizer F/RD M/S EP | 66 | 116 | Polymer, plastic insert | Manual/semi auto | 2 | 3 | 2.2 | 9093 0021 38 |
| Filter+regulator+lubricator | | | | | | | | |
| MIDI Optimizer FRD M/S | 66 | 116 | Polymer, plastic insert | Manual/semi auto | 2 | 3 | 2.4 | 9093 0021 27 |
| MIDI Optimizer FRD A | 66 | 116 | Polymer, plastic insert | Automatic | 2 | 3 | 2.4 | 9093 0021 26 |

NOTE: **Economical air flow:** 116 psi inlet pressure, 91 psi outlet pressure, 3 psi pressure drop.
Maximum air flow: 145 psi inlet pressure, 91 psi outlet pressure, 15 psi pressure drop.

All separate units, mounting brackets, assembly kits and pressure gauges need to be ordered separately. MIDI F/RD unit is delivered complete with mounting bracket, assembly kit and pressure gauge.

EP For pulse tools, lubricator adjusted for impulsing tools
 A Automatic
 M/S Manual/semi automatic
 LP Lockable regulator

The high flow MAXI-B air preparation unit's main application is to prepare the air for pneumatic tools which are large air consumers when long distribution hoses and multi connectors are used. A good example is Atlas Copco Turbo grinders. The MAXI-B has a diecast zinc housing and aluminum bowls with polypropylene inserts and the bowl is directly screwed to the housing for easy handling.

WORKING TEMPERATURE

14°F to 122°F at 145 psi

NOTE: For dry compressed air, ice formation must be avoided.

OPERATING PRESSURE

Inlet pressure 0-254 psi

Outlet pressure 7-174 psi

STANDARD FILTER

30 µm

PRESSURE GAUGE

1/4" BSP



| Model | Economical air flow cfm | Maximum air flow cfm | Bowl | Filter condensate drainage | Max condensate capacity oz | Max oil capacity oz | Weight lb | Ordering No. |
|------------------------------------|-------------------------|----------------------|-------|----------------------------|----------------------------|---------------------|-----------|--------------|
| Filters | | | | | | | | |
| MAXI FIL 25BU-B | 225 | 636 | Metal | Semi/automatic | 4.4 oz | - | 2 | 9093 0074 31 |
| Regulators | | | | | | | | |
| MAXI REG 25BU | 180 | 566 | - | - | - | - | 2.6 | 9093 0074 71 |
| Lubricators | | | | | | | | |
| MAXI DIM 25BU | 184 | 636 | Metal | - | - | 16.9 | 1.8 | 9093 0075 31 |
| Filter/regulator | | | | | | | | |
| MAXI F/R 25BU-B | 178 | 485 | Metal | Semi/automatic | 4.4 oz | - | 3.3 | 9093 0075 61 |
| Filter+regulator+lubricator | | | | | | | | |
| MAXI FRD 25BU-B | 171 | 328 | Metal | Semi/automatic | 4.4 oz | 16.9 | 7.3 | 9093 0076 11 |

NOTE: **Economical air flow:** 116 psi inlet pressure, 91 psi outlet pressure, 3 psi pressure drop.
Maximum air flow: 145 psi inlet pressure, 91 psi outlet pressure, 15 psi pressure drop.

All separate units, mounting brackets, assembly kits and pressure gauges need to be ordered separately. MAXI F/RD unit is delivered complete with mounting bracket, assembly kit and pressure gauge.

Optional Accessories

COMMON ACCESSORIES

| Designation | Ordering No. | |
|-----------------------------|----------------|--------------|
| | MIDI OPTIMIZER | MAXI-B |
| Mounting bracket kit | 9093 0022 01 | 9093 0076 15 |
| Assembly kit | 9093 0022 02 | 9093 0076 31 |

Are included in combination units (FD, FTD, F/RD and FRD)
Common accessories have to be ordered separately for separate units.

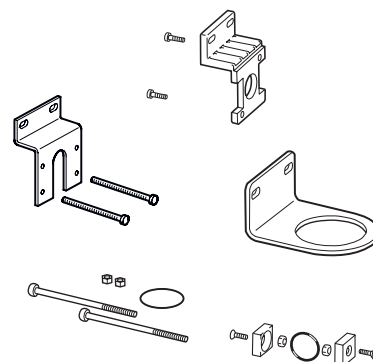

FILTER (FIL) ACCESSORIES (30 µm filter element is included with all filters)

| Designation | Ordering No. | |
|-----------------------|----------------|--------------|
| | MIDI OPTIMIZER | MAXI-B |
| Filter element | | |
| 30 µm | 9093 0023 04 | 9093 0076 61 |
| 5 µm | 9093 0023 05 | 9093 0076 71 |

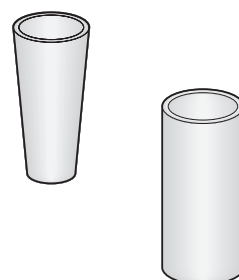

REGULATOR (REG) ACCESSORIES

| Designation | Ordering No. | |
|--------------------------------------|----------------|--------------|
| | MIDI OPTIMIZER | MAXI-B |
| Pressure gauge | | |
| 0-140 psi | | |
| Ø 50 mm | 9090 2052 00 | |
| Metal housing | 9090 2052 01 | |
| 0-230 psi | | |
| Ø 49 mm | 9090 0239 00 | 9090 0239 00 |
| Ø 63 mm | | 9093 0076 45 |
| Panel mounting pressure gauge | | |
| 0-140 psi | | |
| Ø 50 mm | 9090 1173 00 | |
| 0-230 psi | | |
| Ø 63 mm | | 9093 0076 43 |
| Key lock for regulator -LP | 9092 0074 11 | |

Pressure gauge 0-140 psi is included in the combination units (F/RD and FRD)
Pressure gauge has to be ordered separately for separate units.

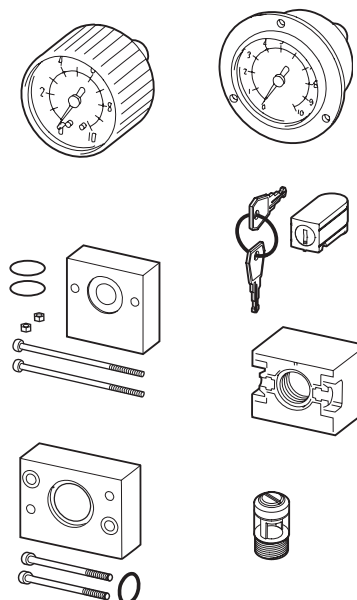

LUBRICATOR (DIM) ACCESSORIES

| Designation | Ordering No. | |
|-----------------------------------|----------------|--------------|
| | MIDI OPTIMIZER | MAXI-B |
| Air distribution block kit | 9093 0022 03 | 9093 0076 41 |
| Glass sight dome | | 9090 1873 00 |



FRL STAND

| Designation | Ordering No. |
|------------------------------|--------------|
| Suits all models | 9090 2101 00 |
| FRL-stand^a | 9090 3030 01 |

^a For impact wrenches and pulse tools up to 1/2" NPT air inlet, and maximum air flow 65 cfm. Includes: large metal gauge up to 145 psi, ErgoQIC 10US coupling, 16.9 oz of Optimizer oil, Turbo 13 hose with length 16.4 ft. The FRL-stand has NPT connection.

OPTIMIZER AIR TOOL OIL

Atlas Copco Optimizer air tool oil is a white, oil based lubricant for pneumatic tools. It has excellent antiwear properties and contains additives preventing oxidation and foaming. The Optimizer air tool oil provides a better working environment, compared to conventional mist lubrication oils and is recommended when stringent demands are placed on the working environment.

- Provides a better working environment.
- Excellent antiwear properties.
- Minimizes wear on components.



Technical Data

| | |
|--------------------|-------------------------|
| Temperature range | -13°F to +158°F |
| Density at 59°F | 0.13 ounce/gallon |
| Viscosity at 104°F | 0.34 in ² /s |
| Pour point | -54°F |
| Flash point COC | >338°F |

| Model | Ordering No. |
|--------------------|--------------|
| Optimizer 16.9 oz | 9090 0000 02 |
| Optimizer 33.8 oz | 9090 0000 04 |
| Optimizer 1 gallon | 9090 0000 06 |

Introduction – Quick Couplings

Simply the best choice!

Whenever tools or pneumatic equipment need to be changed, or you need to make quick connections of hoses to an air outlet, Atlas Copco couplings are simply the best choice.

ENERGY EFFICIENCY

All Atlas Copco couplings are designed for a minimum pressure drop to reduce energy consumption.

PRODUCTIVITY

Exceptionally high air flow will guarantee full power in the tools.

QUALITY

The bodies of the couplings are made of hardened steel with a no-leakage design for long service life and heavy duty applications.

ERGONOMICS

Compact dimensions and low weight.

SAFETY

ErgoQIC's are vented safety versions to minimize the risk of sudden component separation and sound bang. The safety features are according to EN 983 and ISO 4414.



Selection Guide

Atlas Copco offers a broad range of couplings. ErgoQIC 08, ErgoQIC 10, ErgoQIC 08US, ErgoQIC 10US, ErgoQIC 15US, QIC 10US, QIC 15US and CLAW. The ErgoQIC system is a ball valve coupling with a safety feature offering a higher flow than ordinary coupling systems. The Claw coupling is a large bore claw coupling system offering a very high air flow.

For assembly tools, riveting hammers and drills it is recommended that a smaller sized coupling such as ErgoQIC 08 / US is used, but for assembly tools and drills with higher air consumption than 20 l/s it is recommended that ErgoQIC 10,

Standard / Quick coupling / Flow capacity

| | | |
|--------------------------|--------------|---------|
| Atlas Copco standard | ErgoQIC 08 | 62 cfm |
| ISO 6150 B / US standard | ErgoQIC 08US | 34 cfm |
| Atlas Copco standard | ErgoQIC 10 | 129 cfm |
| ISO 6150 B / US standard | ErgoQIC 10US | 89 cfm |
| ISO 6150 B / US standard | ErgoQIC 15US | 161 cfm |
| ISO 6150 B / US standard | QIC 10US | 40 cfm |
| ISO 6150 B / US standard | QIC 15US | 85 cfm |

ErgoQIC 10US or ErgoQIC 15US are used. For grinders and percussive tools it is recommended that the bigger sized couplings ErgoQIC 10, ErgoQIC 10US

or ErgoQIC 15US and Claw are used. For smaller grinders with air consumption below 10 l/s ErgoQIC 08 /US can be used.

Atlas Copco Global standard

ERGOQIC 08

The ErgoQIC 08 is a full flow quick coupling with no air restriction inside the coupling. It is suitable for assembly tools, drills and small grinders. Upgrading any air system with ErgoQIC 08 will give the benefits of productivity and energy efficiency.

- Full flow coupling.
- Ergonomic design, small size and low weight.
- Strong and durable.
- Safety feature according to EN 983 / ISO 4414.





Technical Data

Max flow capacity 62 cfm (7.3 psi ΔP)
 Economical air flow 38 cfm (2.9 psi ΔP)
 Max working pressure 230 psi
 Temperature range 14°F to +158°F

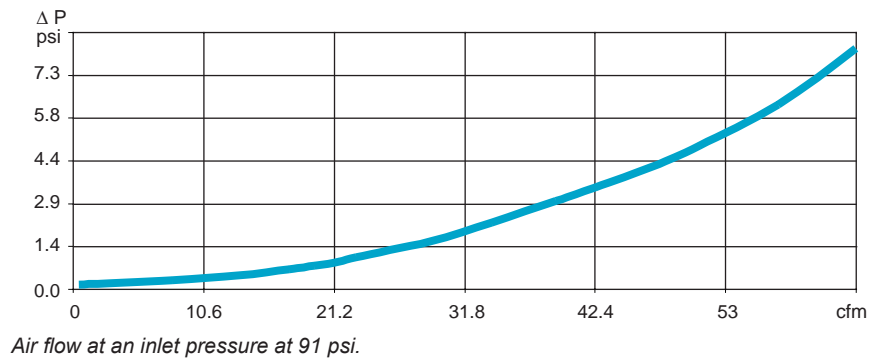
FLOW CHART. ERGOQIC 08 M15U AND ERGONIP 08 M10U

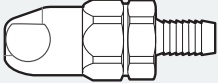

ERGOQIC 08 AND ERGONIP 08, 38 CFM (recommended air flow at 91 psi pressure)

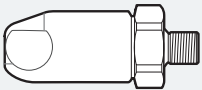
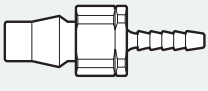
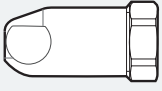
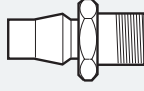
| Connection type | Coupling ErgoQIC 08 | Ordering No. | Size | | Connection type | Nipple ErgoNIP 08 | Ordering No. | Size | |
|---|---------------------|--------------|---------|------|---|-------------------|--------------|---------|------|
| | | | mm | in | | | | mm | in |
|  H – Hose | H06 | 8202 1110 04 | 6.3 | 1/4 |  H – Hose | H06 | 8202 1210 37 | 6.3 | 1/4 |
| | H08 | 8202 1110 12 | 8 | 5/16 | | H08 | 8202 1210 45 | 8 | 5/16 |
| | H10 | 8202 1110 38 | 10 | 3/8 | | H10 | 8202 1210 52 | 10 | 3/8 |
|  M – Male | M08U | 8202 1115 09 | 1/4 NPT | |  SH – Safety Hose ^a | SH06 | 8202 1210 39 | 6.3 | 1/4 |
| | M10U | 8202 1115 17 | 3/8 NPT | | | SH08 | 8202 1210 47 | 8 | 5/16 |
| | M15U | 8202 1115 25 | 1/2 NPT | | | SH10 | 8202 1210 50 | 10 | 3/8 |
|  F – Female | F08U | 8202 1115 30 | 1/4 NPT | |  M – Male | M06U | 8202 1215 08 | 1/8 NPT | |
| | F10U | 8202 1115 35 | 3/8 NPT | | | M08U | 8202 1215 16 | 1/4 NPT | |
| | | | | | | M10U | 8202 1215 24 | 3/8 NPT | |
| Protective cover | | 9090 1940 00 | | | F – Female | F10U | 8202 1215 35 | 3/8 NPT | |

^a For joining hoses longer than 3 meters.

ISO 6150-B / US standard

ERGOQIC 08US

The ErgoQIC 08US is a full flow quick coupling with no air restriction inside the coupling suitable for assembly tools, drills and small grinders. Upgrading any air system with ErgoQIC 08US will give the benefit of productivity and energy efficiency.

- Full flow coupling.
- Ergonomic design, small size and low weight.
- Strong and durable.
- Safety feature according to EN 983 / ISO 4414.



Technical Data

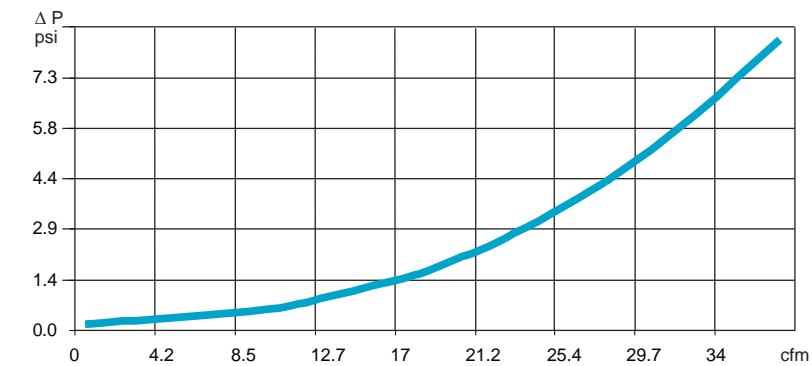

Max flow capacity 34 cfm (7.3 psi ΔP)
 Economical air flow 23 cfm (2.9 psi ΔP)
 Max working pressure 230 psi
 Temperature range 14°F to 158°F

FLOW CHART. ERGOQIC 08US AND NIP 08

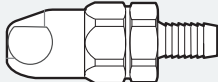
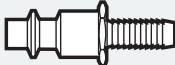
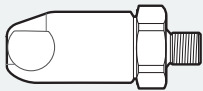
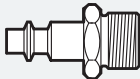

Air flow at an inlet pressure at 91 psi.

ERGOQIC 08US AND NIP 08, 23 CFM (recommended air flow at 91 psi pressure)

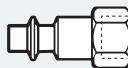
| Connection type | Coupling ErgoQIC 08US | | Size | | Connection type | Nipple NIP 08 | | Size | |
|--|-----------------------|--------------|---------|------|--|---------------|--------------|---------|------|
| | | Ordering No. | mm | in | | | Ordering No. | mm | in |
| H – Hose  | H06 | 8202 1103 00 | 6.3 | 1/4 | H – Hose  | H06 | 8202 1205 18 | 6.3 | 1/4 |
| | H08 | 8202 1103 01 | 8.0 | 5/16 | | H08 | 8202 1205 26 | 8.0 | 5/16 |
| | H10 | 8202 1103 02 | 10.0 | 3/8 | | H10 | 8202 1205 34 | 10.0 | 3/8 |
| | | | | | | H13 | 8202 1208 03 | 12.5 | 1/2 |
| M – Male  | M08U | 8202 1103 04 | 1/4 NPT | | M – Male  | M06U | 8202 1208 07 | 1/8 NPT | |
| | M10U | 8202 1103 06 | 3/8 NPT | | | M08U | 8202 1208 08 | 1/4 NPT | |
| | M15U | 8202 1103 08 | 1/2 NPT | | | M10U | 8202 1208 09 | 3/8 NPT | |
| F – Female  | F08U | 8202 1103 10 | 1/4 NPT | | F – Female  | F08U | 8202 1208 14 | 1/4 NPT | |
| | F10U | 8202 1103 12 | 3/8 NPT | | | F10U | 8202 1208 15 | 3/8 NPT | |

Atlas Copco Global standard

ERGOQIC 10

The ErgoQIC 10 is a full flow coupling with no air restriction inside the coupling. It is suitable for assembly tools, drills and grinders. Upgrading any air system with ErgoQIC 10 will give the benefits of productivity and energy efficiency.

- Extreme full flow coupling.
- Strong and durable.
- Minimized connection force.
- Safety feature according to EN 983 / ISO 4414.





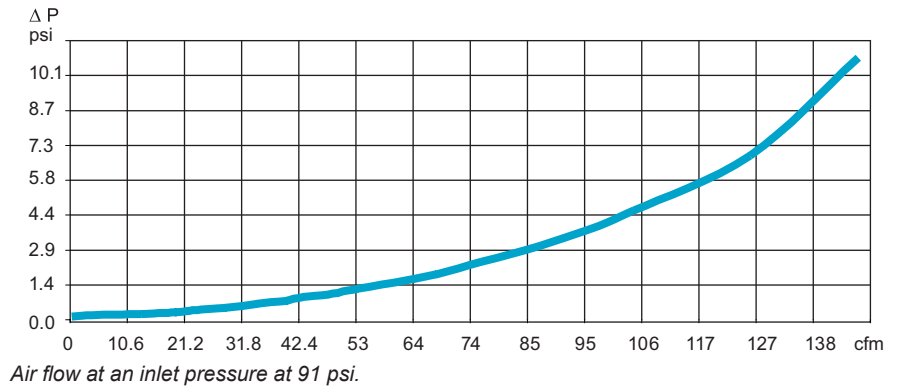

Technical Data

Max flow capacity 129 cfm (7.3 psi ΔP)
 Economical air flow 85 cfm (2.9 psi ΔP)
 Max working pressure 230 psi
 Temperature range 14°F to +158°F

FLOW CHART. ERGOQIC 10 M15U AND ERGONIP 10 M15U

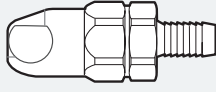

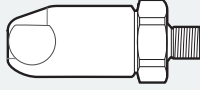
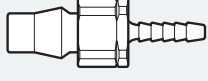
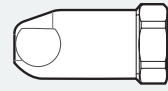
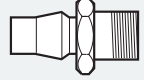
ERGOQIC 10 AND ERGONIP 10, 85 CFM (recommended air flow at 91 psi pressure)

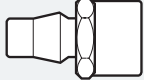
| Connection type | Coupling ErgoQIC 10 | Ordering No. | Size | | Connection type | Nipple ErgoNIP 10 | Ordering No. | Size | |
|---|---------------------|--------------|---------|------|---|-------------------|--------------|---------|------|
| | | | mm | in | | | | mm | in |
|  H – Hose | H06 | 8202 1120 30 | 6.3 | 1/4 |  H – Hose | H06 | 8202 1220 35 | 6.3 | 1/4 |
| | H08 | 8202 1120 40 | 8 | 5/16 | | H08 | 8202 1220 43 | 8 | 5/16 |
| | H10 | 8202 1120 02 | 10 | 3/8 | | H10 | 8202 1220 50 | 10 | 3/8 |
| | H13 | 8202 1120 10 | 12.5 | 1/2 | | H13 | 8202 1220 68 | 12.5 | 1/2 |
| | H16 | 8202 1120 50 | 16 | 5/8 | | H16 | 8202 1220 76 | 16 | 5/8 |
| | H20 | 8202 1120 60 | 19 | 3/4 | | H20 | 8202 1220 77 | 19 | 3/4 |
|  M – Male | M08U | 8202 1125 07 | 1/4 NPT | |  SH – Safety Hose ^a | SH06 | 8202 1220 37 | 6.3 | 1/4 |
| | M10U | 8202 1125 15 | 3/8 NPT | | | SH08 | 8202 1220 45 | 8 | 5/16 |
| | M15U | 8202 1125 23 | 1/2 NPT | | | SH10 | 8220 1220 52 | 10 | 3/8 |
| | | | | | | SH13 | 8202 1220 70 | 12.5 | 1/2 |
|  F – Female | F08U | 8202 1125 30 | 1/4 NPT | |  M – Male | M08U | 8202 1225 06 | 1/4 NPT | |
| | F10U | 8202 1125 35 | 3/8 NPT | | | M10U | 8202 1225 14 | 3/8 NPT | |
| | | | | | | M15U | 8202 1225 22 | 1/2 NPT | |
|  Protective cover | | 9090 1931 00 | | |  F – Female | F08U | 8202 1225 30 | 1/4 NPT | |
| | | | | | | F10U | 8202 1225 32 | 3/8 NPT | |
| | | | | | | F15U | 8202 1225 34 | 1/2 NPT | |

^a For joining hoses longer than 3 meters.

ISO 6150-B / US standard

ERGOQIC 10US

The ErgoQIC 10US is a full flow quick coupling with no air restriction inside the coupling suitable for assembly tools, drills and small grinders. Upgrading any air system with ErgoQIC 10US couplings will give the benefit of productivity and energy efficiency.

- Full flow coupling.
- Ergonomic design, small size and low weight.
- Strong and durable.
- Safety feature according to EN 983 / ISO 4414.



Nipple profile



Technical Data

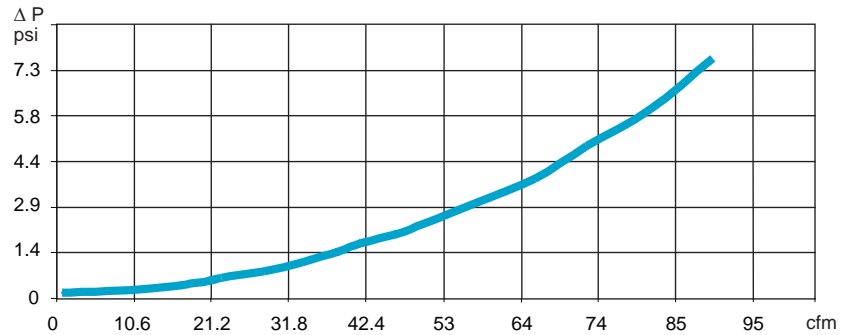

Max flow capacity 89 cfm (7.3 psi ΔP)
 Economical air flow 57 cfm (2.9 psi ΔP)
 Max working pressure 230 psi
 Temperature range 14°F to 158°F

FLOW CHART. ERGOQIC 10US AND NIP 10US

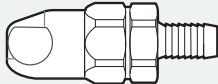

Air flow at an inlet pressure at 91 psi.

ERGOQIC 10US AND NIP 10US, 57 CFM (recommended air flow at 91 psi pressure)

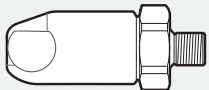
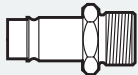
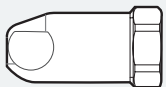
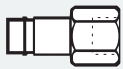
| Connection type | Coupling ErgoQIC 10US | | Size | | Connection type | Nipple NIP 10US | | Size | |
|--|-----------------------|--------------|---------|------|--|-----------------|--------------|---------|------|
| | | Ordering No. | mm | in | | | Ordering No. | mm | in |
| H – Hose  | H08 | 8202 1107 01 | 8.0 | 5/16 | H – Hose  | H08 | 8202 1210 70 | 8.0 | 5/16 |
| | H10 | 8202 1107 02 | 10.0 | 3/8 | | H10 | 8202 1210 71 | 10.0 | 3/8 |
| | H13 | 8202 1107 03 | 12.5 | 1/2 | | H13 | 8202 1210 72 | 12.5 | 1/2 |
| | H16 | 8202 1107 04 | 16.0 | 5/8 | | H13 | 8202 1210 73 | 16.0 | 5/8 |
| | H20 | 8202 1107 05 | 19.0 | 3/4 | | H20 | 8202 1210 74 | 19.0 | 3/4 |
| M – Male  | M08U | 8202 1107 06 | 1/4 NPT | | M – Male  | M08U | 8202 1210 78 | 1/4 NPT | |
| | M10U | 8202 1107 08 | 3/8 NPT | | | M10U | 8202 1210 79 | 3/8 NPT | |
| | M15U | 8202 1107 10 | 1/2 NPT | | | M15U | 8202 1210 80 | 1/2 NPT | |
| F – Female  | F08U | 8202 1107 12 | 1/4 NPT | | F – Female  | F08U | 8202 1210 84 | 1/4 NPT | |
| | F10U | 8202 1107 14 | 3/8 NPT | | | F10U | 8202 1210 85 | 3/8 NPT | |
| | F15U | 8202 1107 16 | 1/2 NPT | | | F15U | 8202 1210 86 | 1/2 NPT | |

ISO 6150-B / US standard

QIC 10US

The QIC 10US quick coupling is suitable for assembly tools, drills and small grinders. The QIC 10US has a wide range of connections available and it is interchangeable with US 3/8" standard nipples.

- High flow.
- One-hand operation.
- Strong and durable.
- Main market: Global.



Nipple profile



Technical Data

Max flow capacity 40 cfm (7.3 psi ΔP)
 Economical air flow 25 cfm (2.9 psi ΔP)
 Max working pressure 145 psi
 Temperature range -4°F to 176°F

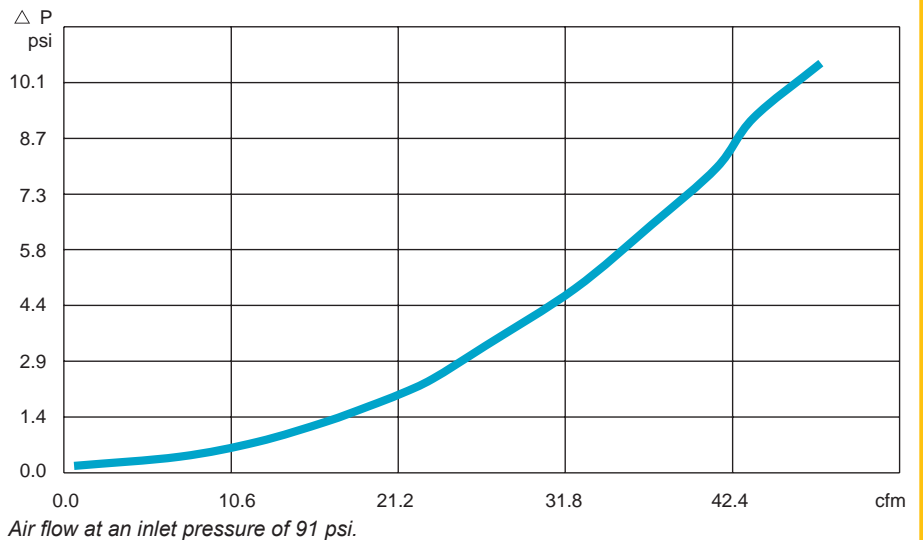
FLOW CHART. QIC 10US AND NIP 10US

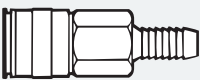

QIC 10US AND NIP 10US, 25 CFM (recommended air flow at 91 psi pressure)

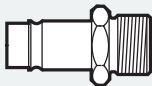
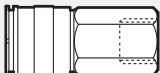
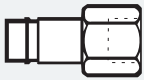
| Connection type | Coupling QIC 10US | Ordering No. | Size | | Connection type | Nipple NIP 10US | Ordering No. | Size | |
|--|-------------------|--------------|---------|------|---|-----------------|--------------|---------|------|
| | | | mm | in | | | | mm | in |
| H – Hose  | H08 | 8202 1307 01 | 8 | 5/16 | H – Hose  | H08 | 8202 1210 70 | 8 | 5/16 |
| | H10 | 8202 1307 02 | 10 | 3/8 | | H10 | 8202 1210 71 | 10 | 3/8 |
| | H13 | 8202 1307 03 | 12.5 | 1/2 | | H13 | 8202 1210 72 | 12.5 | 1/2 |
| | | | | | | H16 | 8202 1210 73 | 16 | 5/8 |
| | | | | H20 | | 8202 1210 74 | 19 | 3/4 | |
| M – Male  | M08U | 8202 1307 04 | 1/4 NPT | | M – Male  | M08U | 8202 1210 78 | 1/4 NPT | |
| | M10U | 8202 1307 05 | 3/8 NPT | | | M10U | 8202 1210 79 | 3/8 NPT | |
| | M15U | 8202 1307 06 | 1/2 NPT | | | M15U | 8202 1210 80 | 1/2 NPT | |
| F – Female  | F08U | 8202 1307 07 | 1/4 NPT | | F – Female  | F08U | 8202 1210 84 | 1/4 NPT | |
| | F10U | 8202 1307 08 | 3/8 NPT | | | F10U | 8202 1210 85 | 3/8 NPT | |
| | F15U | 8202 1307 09 | 1/2 NPT | | | F15U | 8202 1210 86 | 1/2 NPT | |

ISO 6150-B / US standard

ERGOQIC 15US

The ErgoQIC 15US is a full flow coupling with no air restriction inside the coupling suitable for large air consuming assembly tools, drills and grinders. Upgrading any air system with ErgoQIC 15US will give the benefit of productivity and energy efficiency.

- Extreme full flow coupling.
- Strong and durable.
- Minimized connection force.
- Safety feature according to EN 983 / ISO 4414.



Nipple profile



Technical Data

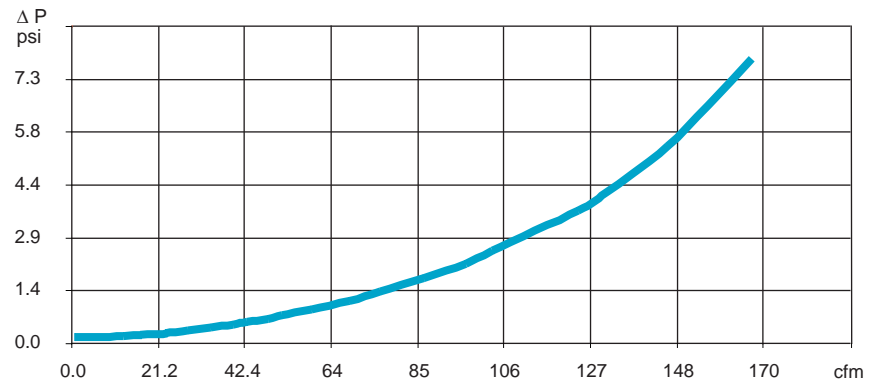

Max flow capacity 161 cfm (7.3 psi ΔP)
 Economical air flow 110 cfm (2.9 psi ΔP)
 Max working pressure 230 psi
 Temperature range 14°F to +158°F

FLOW CHART. ERGOQIC 15US AND NIP 15US

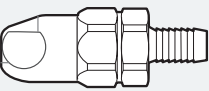

Air flow at an inlet pressure at 91 psi.

ERGOQIC 15 US AND NIP 15 US, 110 CFM (recommended air flow at 91 psi pressure)

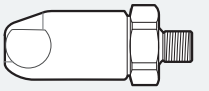
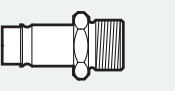
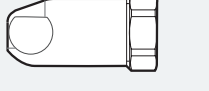
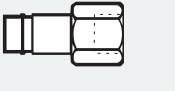
| Connection type | Coupling ErgoQIC 15US | | Size | | Connection type | Nipple NIP 15US | | Size | |
|--|-----------------------|--------------|------|-----|--|-----------------|--------------|------|-----|
| | | Ordering No. | mm | in | | | Ordering No. | mm | in |
| H – Hose  | H10 | 8202 1108 02 | 10.0 | 3/8 | H – Hose  | H10 | 8202 1215 40 | 10.0 | 3/8 |
| | H13 | 8202 1108 03 | 12.5 | 1/2 | | H13 | 8202 1215 41 | 12.5 | 1/2 |
| | H16 | 8202 1108 04 | 16.0 | 5/8 | | H16 | 8202 1215 42 | 16.0 | 5/8 |
| | H20 | 8202 1108 05 | 19.0 | 3/4 | | H20 | 8202 1215 43 | 19.0 | 3/4 |
| M – Male  | M10U | 8202 1108 08 | 3/8 | NPT | M – Male  | M10U | 8202 1215 49 | 3/8 | NPT |
| | M15U | 8202 1108 10 | 1/2 | NPT | | M15U | 8202 1215 50 | 1/2 | NPT |
| | | | | | | M20U | 8202 1215 51 | 3/4 | NPT |
| F – Female  | F10U | 8202 1108 14 | 3/8 | NPT | F – Female  | F10U | 8202 1215 54 | 3/8 | NPT |
| | F15U | 8202 1108 16 | 1/2 | NPT | | F15U | 8202 1215 55 | 1/2 | NPT |
| | | | | | | F20U | 8202 1215 56 | 3/4 | NPT |

ISO 6150-B / US standard

QIC 15US

The QIC 15US quick coupling is suitable for assembly tools, drills and grinders. The QIC 15US has a wide range of connections available and it is interchangeable with US 3/8" standard nipples.

- Exceptional high flow.
- One-hand operation.
- Strong and durable.
- Main market: Global.



Nipple profile



Technical Data

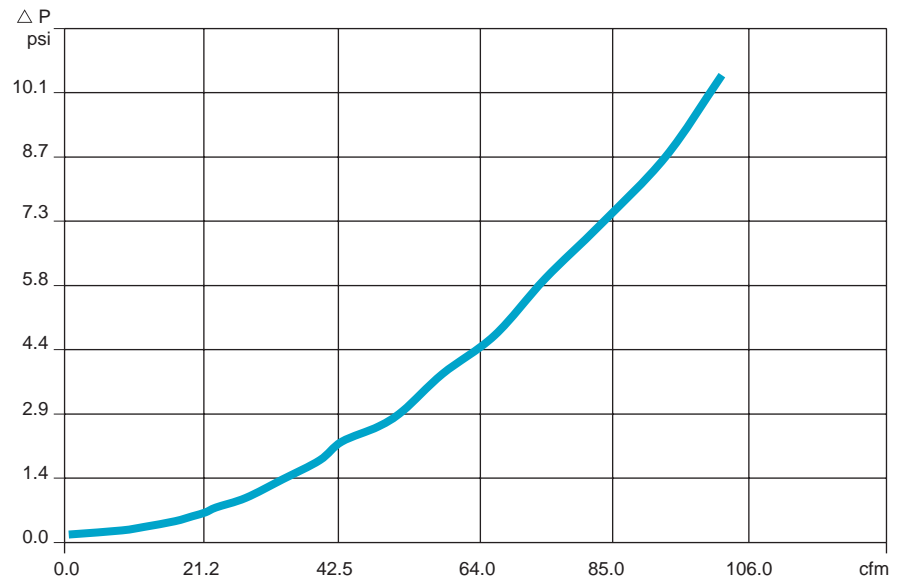

Max flow capacity 85 cfm (7.3 psi ΔP)
 Economical air flow 47 cfm (2.9 psi ΔP)
 Max working pressure 145 psi
 Temperature range -4°F to +176°F

FLOW CHART. QIC 15US AND NIP 15US

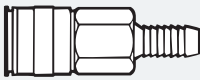

Air flow at an inlet pressure of 91 psi.

QIC 15US AND NIP 15US, 47 CFM (recommended air flow at 91 psi pressure)

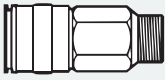
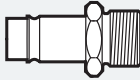
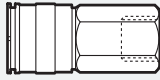
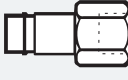
| Connection type | Coupling QIC 15US | Ordering No. | Size | | Connection type | Nipple NIP 15US | Ordering No. | Size | |
|--|-------------------|--------------|---------|-----|---|-----------------|--------------|---------|-----|
| | | | mm | in | | | | mm | in |
| H – Hose  | H13 | 8202 1308 02 | 12.5 | 1/2 | H – Hose  | H10 | 8202 1215 40 | 10 | 3/8 |
| | H16 | 8202 1308 20 | 16 | 5/8 | | H13 | 8202 1215 41 | 12.5 | 1/2 |
| | H20 | 8202 1308 03 | 19 | 3/4 | | H16 | 8202 1215 42 | 16 | 5/8 |
| | | | | | | H20 | 8202 1215 43 | 19 | 3/4 |
| M – Male  | M10U | 8202 1308 04 | 3/8 NPT | | M – Male  | M10U | 8202 1215 49 | 3/8 NPT | |
| | M15U | 8202 1308 05 | 1/2 NPT | | | M15U | 8202 1215 50 | 1/2 NPT | |
| | M20U | 8202 1308 06 | 3/4 NPT | | | M20U | 8202 1215 51 | 3/4 NPT | |
| F – Female  | F10U | 8202 1308 07 | 3/8 NPT | | F – Female  | F10U | 8202 1215 54 | 3/8 NPT | |
| | F15U | 8202 1308 08 | 1/2 NPT | | | F15U | 8202 1215 55 | 1/2 NPT | |
| | F20U | 8202 1308 09 | 3/4 NPT | | | F20U | 8202 1215 56 | 3/4 NPT | |

CLAW couplings are made from drop-forged, hardened steel which can withstand rough treatment and ensures a long life even under difficult conditions. The coupling head is the same for all sizes, which can therefore be freely combined.

The recommended maximum working pressure is 10 bar.

- Large bore – machined surfaces give low air resistance and minimum pressure drop.
- Robust claws – will withstand rough handling without deformation.
- Locking lugs – precision-made to provide a reliable lock.
- Special rubber packings – resistant to oil and temperature changes. Max. temperature 80°C (176°F).
- Packing seats – lathe-turned grooves ensure a leak-proof seal.
- Couplings are zinc-plated and thus effectively treated against corrosion.



FLOW CHART. FOR 2 PIECES OF CLAW

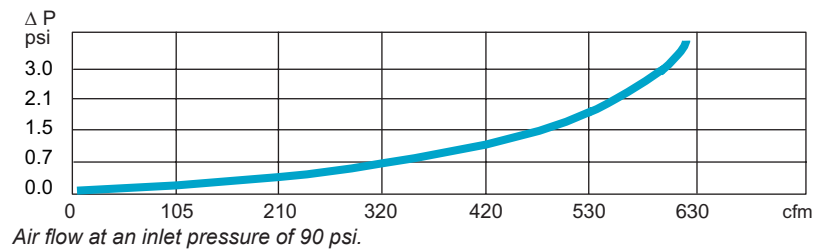

CLAW

| Connection type | Coupling CLAW | Ordering No. | Hose inner dia. | | Bore | | |
|-------------------------------------|---------------|--------------|-----------------|----------|------|----|-------|
| | | | mm | in | mm | in | |
| H – Hose | | H10 | 9001 0005 11 | 10.0 | 3/8 | 6 | 15/64 |
| | | H13 | 9001 0005 10 | 12.5 | 1/2 | 9 | 23/64 |
| | | H20 | 9001 0005 12 | 20.0 | 3/4 | 14 | 9/16 |
| | | H25 | 9001 0005 13 | 25.0 | 1 | 20 | 3/4 |
| M – Male thread | | M10 | 9001 0005 00 | 3/8" NPT | | 9 | 23/64 |
| | | M15 | 9001 0005 01 | 1/2" NPT | | 12 | 15/32 |
| | | M20 | 9001 0005 02 | 3/4" NPT | | 17 | 43/64 |
| | | M25 | 9001 0005 03 | 1" NPT | | 20 | 3/4 |
| F – Female thread | | F10 | 9001 0005 08 | 3/8" NPT | | 15 | 19/32 |
| | | F15 | 9001 0005 05 | 1/2" NPT | | 18 | 23/32 |
| | | F20 | 9001 0005 06 | 3/4" NPT | | 20 | 3/4 |
| | | F25 | 9001 0005 07 | 1" NPT | | 20 | 3/4 |
| Protection cover for CLAW couplings | | 9001 0005 22 | | | | | |
| Extra packing for CLAW couplings | | 9001 0005 15 | | | | | |
| Safety lock spring | | 9001 0005 23 | | | | | |

BAL-1A

The Atlas Copco valve BAL-1A are suitable for air, water and many other liquids and gases due to the choice of material.

- Lubricated with silicone-free grease which is important when spray-painting.
- Maximum through flow – Full bore valve to DIN standards.
- Housing and ball made of chrome-plated hot-stamped brass MS 58.
- Handle of enamelled aluminum.
- * With teflon seals.



Technical Data

Maximum working pressure: 232 psi
 Working temperature range:
 -22°F to +392°F.

| Model | Connection thread in NPT | Bore D in | L in | H in | I in | Ordering No. |
|-----------|--------------------------|-----------|------|------|------|--------------|
| BAL-1A 15 | 1/2 | 0.6 | 2.4 | 2 | 3.7 | 8202 0306 30 |
| BAL-1A 25 | 1 | 1 | 3.3 | 2.6 | 4.8 | 8202 0306 46 |

Dimensions

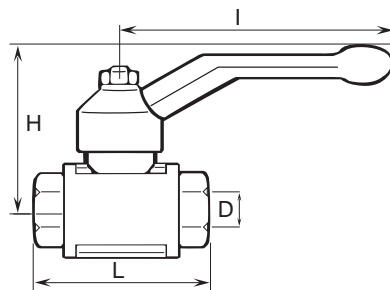

MULTIFLEX SWIVEL MULTI-DIRECTIONAL CONNECTOR

The MultiFlex swivel is an ingenious multi-directional connector. Connect your tool and the hose will stay in the ideal position however much you and the tool move around. The MultiFlex bends and rotates 360° in all directions while the hose stays straight. It takes the effort out of working in those cramped spaces. What's more, the hose feels almost weightless and it reduces hose wear. It's the magic of MultiFlex – a marriage of ergonomic thinking and ingenious design.

- Ergonomic.
- Reduces hose wear.
- High flow capacity.
- Minimum pressure drop.
- Strong and durable.



| Model | Max rec. air flow ^a | | Thread | | Weight lb | Length in | Dia in | Ordering No. |
|---------------------------------|--------------------------------|-----|-----------------|----------------|-----------|-----------|--------|--------------|
| | | | Inlet female in | Outlet male in | | | | |
| MultiFlex 1/8" NPT | 12 | 25 | 1/8 | 1/8 | 0.16 | 2.6 | 0.94 | 8202 1350 25 |
| MultiFlex 1/4" NPT | 12 | 25 | 1/4 | 1/4 | 0.16 | 2.6 | 0.94 | 8202 1350 26 |
| MultiFlex 3/8" NPT | 32 | 68 | 3/8 | 3/8 | 0.29 | 3.2 | 1.16 | 8202 1350 28 |
| MultiFlex 1/2" NPT | 32 | 68 | 1/2 | 1/2 | 0.28 | 3.2 | 1.16 | 8202 1350 30 |
| MultiFlex 1/8" NPT ^b | 12 | 25 | 1/8 | 1/8 | 0.17 | 2.6 | 1.06 | 8202 1350 50 |
| MultiFlex 1/4" NPT ^b | 12 | 25 | 1/4 | 1/4 | 0.17 | 2.6 | 1.06 | 8202 1350 51 |
| MultiFlex 1/2" NPT ^c | 54 | 114 | 1/2 | 1/2 | 0.72 | 3.87 | 1.54 | 8202 1350 62 |

^a The pressure drop will be 2.9 psi at an inlet pressure of 87 psi.

^b With cover.
^c HIGH FLOW.

FLOW CHART

MULTIFLEX 1/2" OR 3/8"

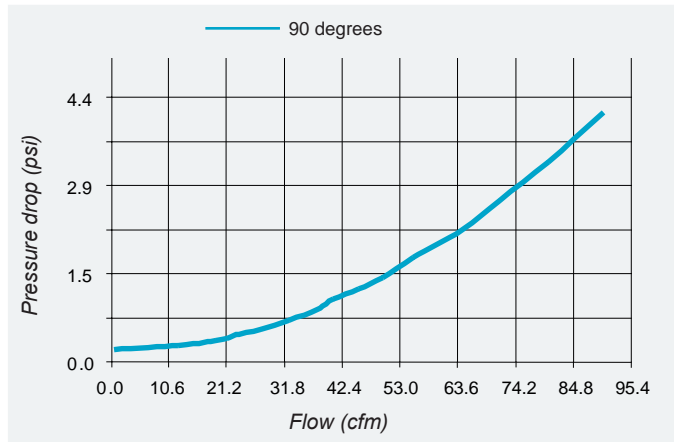

MULTIFLEX 1/8" OR 1/4"

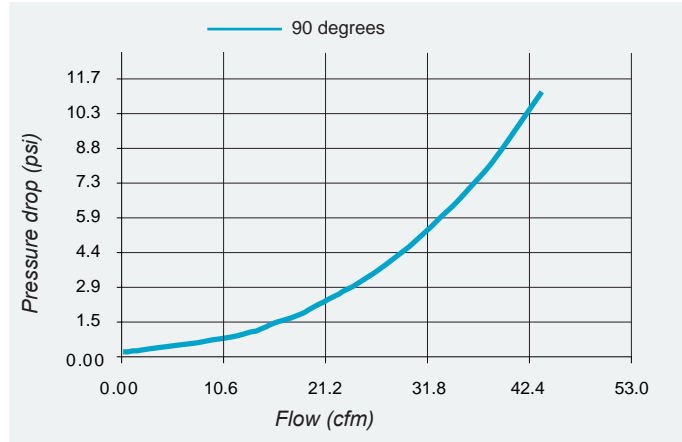

MULTIFLEX HIGH FLOW

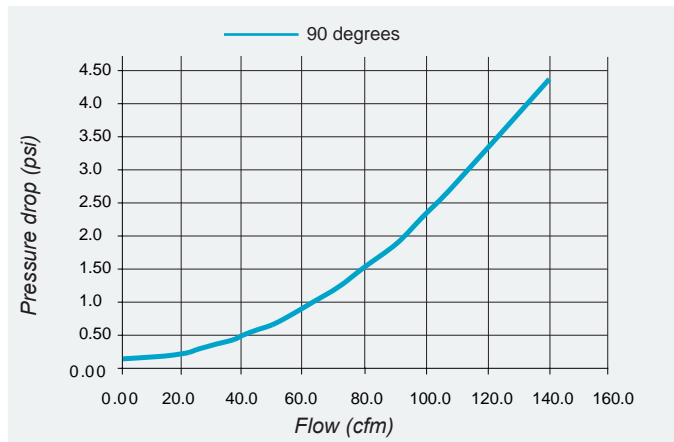

SIMPLE PRESSURE CLAMPS FOR PVC HOSES



| For CABLAIR | For PVC | One-lugged steel clamp mm | Ordering No. |
|-------------|---------|---------------------------|--------------|
| – | – | 5.2- 6.2 | 0347 0122 18 |
| – | – | 5.9- 7.0 | 0347 0122 19 |
| – | 03 | 7.0- 8.5 | 0347 0122 05 |
| 06 | 05 | 8.5-10.0 | 0347 0122 06 |
| 08 | 06 | 9.8-11.8 | 0347 0122 07 |
| – | 08 | 11.3-13.3 | 0347 0122 08 |
| 10 | – | 12.8-14.8 | 0347 0122 09 |
| – | 10 | 14.6-16.8 | 0347 0122 10 |
| 13 | – | 16.5-18.8 | 0347 0122 11 |
| – | 13 | 18.0-20.3 | 0347 0122 12 |
| 16 | – | 20.2-22.8 | 0347 0122 13 |
| – | – | 22.0-24.8 | 0347 0122 14 |
| 20 | – | 23.3-26.3 | 0347 0122 15 |
| – | – | 26.5-30.0 | 0347 0122 16 |
| 25 | – | 29.8-33.1 | 0347 0122 22 |

GASKETS



| For couplings with male parallel thread | Fiber gasket between material and nipple Ordering No. |
|---|---|
| M5 | 0657 5710 00 |
| 1/8" NPT | 0657 5742 00 |
| 1/4" NPT | 0657 5764 00 |
| 3/8" NPT | 0657 5785 00 |
| 1/2" NPT | 0653 0500 01 |
| 3/4" NPT | 0657 5823 00 |
| 1" NPT | 0657 5830 00 |

MEDIUM PRESSURE CLAMPS FOR PVC HOSES



| For CABLAIR | For PVC, POLUR | Medium clamp worm drive mm | Ordering No. |
|-------------|----------------|----------------------------|--------------|
| – | – | 8.0-14.0 | 0347 6102 00 |
| – | 08 | 11.0-17.0 | 0347 6103 00 |
| – | 10 | 11.0-17.0 | 0347 6103 00 |
| – | – | 13.0-20.0 | 0347 6104 00 |
| 16 | 13 | 15.0-24.0 | 0347 6105 00 |
| 20 | 16 | 19.0-28.0 | 0347 6106 00 |
| – | 20 | 22.0-32.0 | 0347 6107 00 |
| 25 | 25 | 26.0-38.0 | 0347 6109 00 |
| – | – | 32.0-44.0 | 0347 6111 00 |
| – | – | 38.0-50.0 | 0347 6112 00 |
| – | – | 50.0-65.0 | 0347 6113 00 |

DOUBLE CONNECTION

Male taper thread – male taper thread



| From thread in | To thread in | Ordering No. |
|----------------|--------------|--------------|
| 1/2 NPT | 1/2 NPT | 9090 0160 01 |
| 1 NPT | 1 NPT | 9090 0200 01 |

MEDIUM PRESSURE CLAMPS FOR RUBBER HOSES



| For TURBO | For RUBBER | Medium clamp worm drive mm | Ordering No. |
|-----------|------------|----------------------------|--------------|
| – | 06 | 11.0-17.0 | 0347 6103 00 |
| 13 | 10 | 13.0-20.0 | 0347 6104 00 |
| 16 | 13 | 15.0-24.0 | 0347 6105 00 |
| – | 16 | 19.0-28.0 | 0347 6106 00 |
| 20 | – | 22.0-32.0 | 0347 6107 00 |
| – | 20 | 26.0-38.0 | 0347 6109 00 |

HEAVY-DUTY PRESSURE CLAMPS FOR RUBBER HOSES



| For TURBO | For RUBBER | Heavy-duty clamp mm | Ordering No. |
|-----------|------------|---------------------|--------------|
| – | – | 22.0-25.0 | 9000 0194 00 |
| 20 | 16 | 25.0-28.0 | 9000 0195 00 |
| – | 20 | 29.0-32.0 | 9000 0196 00 |
| – | 25 | 34.0-38.0 | 9000 0197 00 |

Pressure drop diagram for straight hoses

This diagram helps you to choose the right hose according to the air consumption of the tool and the length of the hose. The purpose of the diagram is to ensure that the pressure drop in the hoses does not exceed 2.9 psi.

HOW TO READ THE DIAGRAM:

Look up the tools required air consumption at 87 psi.

Use this value in the diagram .

What length of hose do you need?

Look at the diagram to see which hose size you need.

Decide which type of hose you need, Atlas Copco Tools has seven different hoses covering all types of needs for pneumatic hand tools.

EXAMPLE

The tool has an air consumption of 21 cfm and the application requires a hose length of 23 ft. These two values have a cross point slightly under the 3/8 inch size hose (23 ft of 3/8 inch hose gives a value of approximately 23.3 cfm).

Therefore a 3/8 inch hose will be suitable.

PRESSURE DROP DIAGRAM FOR HOSES

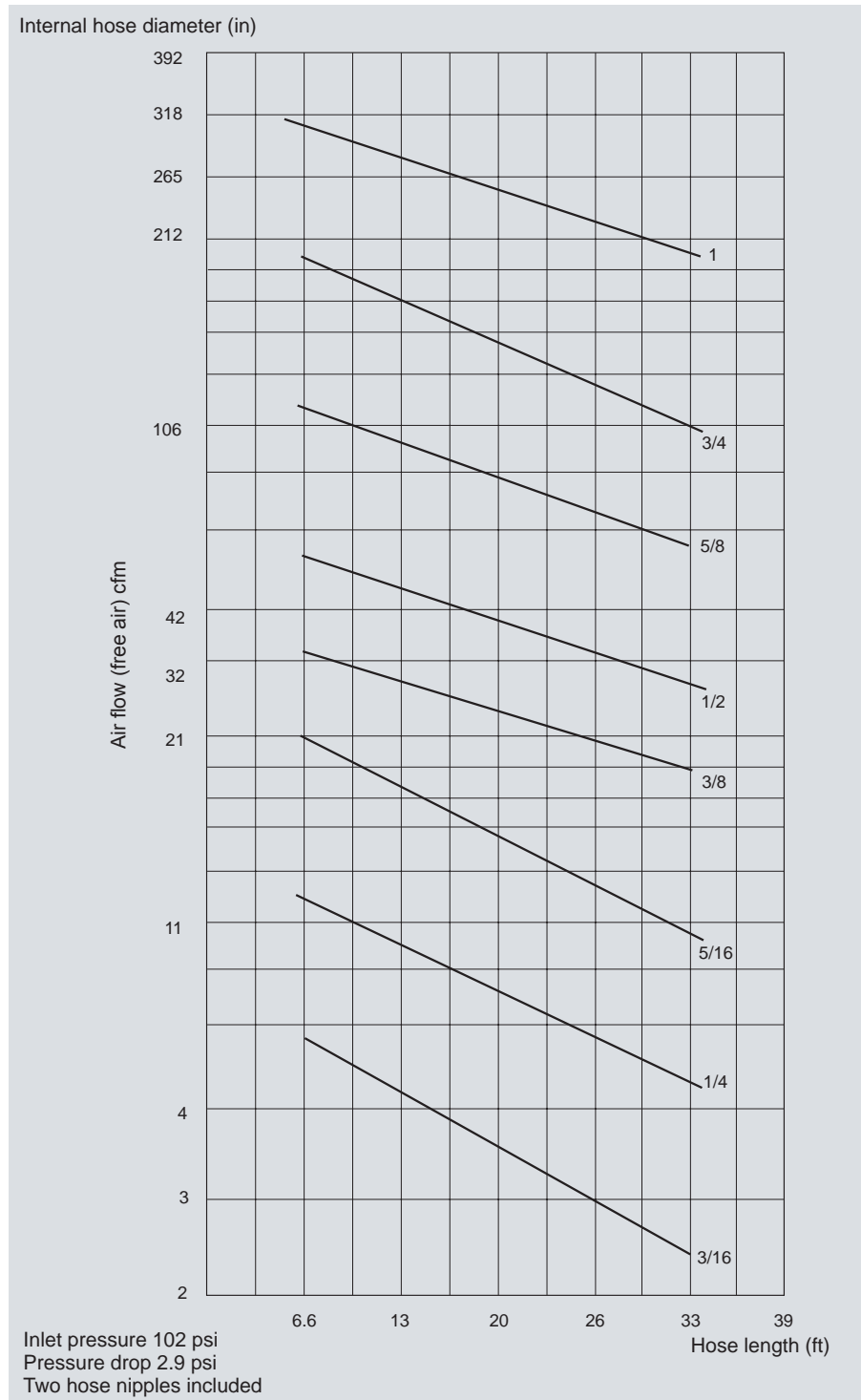

CABLAIR HOSES
SUPER-LIGHT FLEXIBLE PVC-HOSE

Cablair is made of high-strength, high performance PVC compound. The Cablair hose weighs 30-50% less and is much softer and more flexible than conventional PVC hoses. This ensures complete freedom of movement for operators of pneumatic hand tools in any working environment.

- Low weight.
- Extremely soft and flexible.
- Silicone free.
- Ergonomic.
- Working temperature +5°F to +140°F.



| Model | Hose inside dia in | Hose outside dia in | Max working pressure ^a psi | Max rec. air flow ^b cfm | Weight per 101 ft coil lb | Ordering No. |
|------------|--------------------|---------------------|---------------------------------------|------------------------------------|---------------------------|--------------|
| CABLAIR 06 | 1/4 | 7/20 | 260 | 9 | 2.6 | 9093 0035 11 |
| CABLAIR 08 | 1/3 | 2/5 | 260 | 16 | 3.7 | 9093 0035 41 |
| CABLAIR 10 | 2/5 | 1/2 | 203 | 28 | 4.6 | 9093 0035 71 |
| CABLAIR 13 | 1/2 | 13/20 | 188 | 45 | 6.6 | 9093 0036 01 |
| CABLAIR 16 | 5/8 | 4/5 | 160 | 91 | 11.9 | 9093 0036 31 |
| CABLAIR 20 | 3/4 | 19/20 | 160 | 159 | 12.8 | 9093 0036 61 |
| CABLAIR 25 | 1 | 1 1/5 | 145 | 265 | 23 | 9093 0036 91 |

^aWith a safety factor of 3 at 68°F (at the max temp of +140°F the working pressure should be reduced by 50%).
^bThe pressure drop will be 3 psi on a hose length of 16 ft.

CABLAIR ESD
EXTRA FLEXIBLE ANTISTATIC AIR HOSE

Cablair ESD is an extra flexible antistatic air hose designed specifically for use within the computer manufacturing industry. The hose possesses properties which enable ESDS (electrostatic sensitive devices) to be handled in a protected area with a low risk level, as a result of electrostatic discharge. In addition to a known demand in the computer industry, it is expected that potential exists in the electronics, radio and communication fields. The connection device must be earthed/grounded.

- Extra flexible.
- Antistatic.
- Silicone free.
- Testing in accordance with BS2050:1978 (1998) 4.12.
- Working temperature +5°F to +140°F.



| Model | Hose inside dia in | Hose outside dia in | Max working pressure ^a psi | Max rec. air flow cfm | Weight per 101 ft coil lb | Ordering No. |
|----------------|--------------------|---------------------|---------------------------------------|-----------------------|---------------------------|--------------|
| CABLAIR ESD 06 | 1/4 | 7/16 | 145 | 9 | 5 | 8202 0501 06 |
| CABLAIR ESD 08 | 5/16 | 1/2 | 130 | 16 | 5.6 | 8202 0501 08 |
| CABLAIR ESD 10 | 3/8 | 9/16 | 116 | 28 | 6 | 8202 0501 10 |
| CABLAIR ESD 13 | 1/2 | 23/32 | 101 | 45 | 9.7 | 8202 0501 13 |

^aWith a safety factor of 3 at 68°F (at the max temp of +140°F the working pressure should be reduced by 50%).

PVC HOSES

STRONG PVC HOSE FOR HEAVY-DUTY APPLICATIONS

The PVC hose has high resistance to abrasion, which makes it the ideal hose for tough working environments such as workshops, factories, garages, etc. It is mainly recommended for indoor use.

- Long service life.
- Pliable.
- Transparent.
- Working temperature +5°F to +140°F.



| Model | Hose inside dia in | Hose outside dia in | Max working pressure ^a psi | Max rec. air flow ^b cfm | Weight per 101 ft coil lb | Ordering No. |
|--------|--------------------|---------------------|---------------------------------------|------------------------------------|---------------------------|--------------|
| PVC 03 | 1/8 | 11/40 | 290 | 2 | 3 | 9093 0037 21 |
| PVC 05 | 3/16 | 7/20 | 261 | 5 | 4 | 9093 0037 51 |
| PVC 06 | 1/4 | 2/5 | 261 | 9 | 5.5 | 9093 0037 81 |
| PVC 08 | 5/16 | 1/2 | 261 | 16 | 6.4 | 9093 0038 11 |
| PVC 10 | 3/8 | 11/20 | 203 | 28 | 8 | 9093 0038 41 |
| PVC 13 | 1/2 | 7/10 | 188 | 45 | 13 | 9093 0038 71 |
| PVC 16 | 5/8 | 9/10 | 174 | 91 | 16 | 9093 0039 01 |
| PVC 20 | 3/4 | 1 | 174 | 159 | 18 | 9093 0039 31 |
| PVC 25 | 1 | 1 1/5 | 160 | 265 | 27.5 | 9093 0039 61 |

^aWith a safety factor of 3 at 68°F (at the max temp of +140°F the working pressure should be reduced by 50%).

^bThe pressure drop will be 3 psi on a hose length of 16 ft.

POLUR

HIGH RESISTANT POLYURETHANE HOSE

The Polur hose is the most environmentally friendly solution. It has high resistance to abrasion and it is oil resistant. The Polur hose has a much longer lifetime than PVC hoses. The Polur is ideal in tough working conditions such as workshops, factories, garages, shipyards and construction sites due to its flexibility, even at minus degrees. Polur is recommended for indoor and outdoor use.

- Oil resistant.
- Flexible.
- Long service life.
- Working temperature -22°F to +140°F.



| Model | Hose inside dia in | Hose outside dia in | Max working pressure ^a psi | Max rec. air flow ^b cfm | Weight per 82 ft coil lb | Ordering No. |
|----------|--------------------|---------------------|---------------------------------------|------------------------------------|--------------------------|--------------|
| POLUR 08 | 5/16 | 1/2 | 290 | 16 | 5 | 8202 0601 08 |
| POLUR 10 | 3/8 | 11/20 | 232 | 28 | 5.5 | 8202 0602 10 |
| POLUR 13 | 1/2 | 7/10 | 188 | 45 | 9 | 8202 0603 13 |

^aWith a safety factor of 3 at 68°F (at the max temp of +176°F the working pressure should be reduced by 50%).

^bThe pressure drop will be 3 psi on a hose length of 16 ft, including 2 nipples and at an inlet pressure of 101 psi.

TURBO **SUPER-LIGHT FLEXIBLE RUBBER** **HOSE**

The Turbo hose has been developed for flexible use both indoor and outdoor. The hose weighs 30-40% less than conventional rubber hoses, making it ideal for foundries, shipyards, engineering workshops and construction sites. The Turbo hose is oil resistant.

- Extremely low weight.
- Soft and flexible.
- Antistatic.
- Grinding and welding spatter resistant.
- Working temperature -22°F to +158°F.



| Model | Hose inside dia in | Hose outside dia in | Max working pressure ^a psi | Max rec. air flow ^b cfm | Weight per | | Ordering No. |
|----------|--------------------|---------------------|---------------------------------------|------------------------------------|---------------|----------------|--------------|
| | | | | | 65 ft coil lb | 101 ft coil lb | |
| TURBO 13 | 1/2 | 3/4 | 232 | 45 | 8.5 | – | 9093 0057 91 |
| TURBO 13 | 1/2 | 3/4 | 232 | 45 | – | 13 | 9093 0057 93 |
| TURBO 16 | 2/3 | 9/10 | 232 | 91 | 10.5 | – | 9093 0057 31 |
| TURBO 16 | 2/3 | 9/10 | 232 | 91 | – | 16 | 9093 0057 33 |
| TURBO 20 | 5/6 | 1 | 232 | 159 | 12 | – | 9093 0057 61 |
| TURBO 20 | 5/6 | 1 | 232 | 159 | – | 17.9 | 9093 0057 62 |

^a With a safety factor of 3 at 68°F.

^b The pressure drop will be 3 psi on a hose length of 16 ft, including 2 nipples and at an inlet pressure of 101 psi.

RUBBER **DURABLE REINFORCED HEAVY** **DUTY RUBBER HOSE**

The hose withstands rough handling and is suitable for the most demanding tasks in construction, mining, shipyards, foundries etc. The inner lining is black EPDM rubber, conductive to dissipate static electricity. Reinforcement with high tensile strength made of synthetic textile yarns.

- Durable.
- Antistatic.
- Grinding and welding spatter resistant.
- Working temperature -13°F to +158°F.



| Model | Hose inside dia in | Hose outside dia in | Max working pressure ^a psi | Max rec. air flow ^b cfm | Length ft | Weight lb | Ordering No. |
|-----------|--------------------|---------------------|---------------------------------------|------------------------------------|-----------|-----------|--------------|
| | | | | | | | |
| RUBBER 10 | 3/8 | 2/3 | 232 | 27 | 98 | 15.2 | 9030 2037 00 |
| RUBBER 13 | 1/2 | 5/8 | 232 | 44 | 98 | 27.1 | 9030 2038 00 |
| RUBBER 16 | 5/8 | 3/4 | 232 | 91 | 98 | 30.6 | 9030 2039 00 |
| RUBBER 20 | 3/4 | 1 1/5 | 232 | 159 | 98 | 42.5 | 9030 2040 00 |
| RUBBER 20 | 3/4 | 1 1/5 | 232 | 159 | 65 | 28.4 | 9030 2040 03 |
| RUBBER 25 | 1 | 1 1/2 | 232 | 265 | 98 | 52.9 | 9030 2041 00 |
| RUBBER 25 | 1 | 1 1/2 | 232 | 265 | 65 | 32.3 | 9030 2041 03 |

^a With a safety factor of 5 at 68°F.

^b The pressure drop will be 3 psi on a hose length of 16 ft, including 2 nipples and at an inlet pressure of 101 psi.

RUBAIR

DURABLE REINFORCED HEAVY DUTY RUBBER HOSE

The Rubair hose is double reinforced to fulfil all general heavy duty demands and is recommended for indoor and outdoor use. The Rubair hose is oil resistant.

- Durable.
- Antistatic.
- Grinding and welding spatter resistant.
- Working temperature -4°F to +176°F.



| Model | Hose inside dia in | Hose outside dia in | Max working pressure ^a psi | Max rec. air flow ^b cfm | Weight per 65 ft coil lb | Ordering No. |
|-----------|--------------------|---------------------|---------------------------------------|------------------------------------|--------------------------|--------------|
| RUBAIR 10 | 3/8 | 5/8 | 232 | 27 | 7.9 | 8202 0402 10 |
| RUBAIR 13 | 1/2 | 3/4 | 232 | 44 | 10.4 | 8202 0403 13 |
| RUBAIR 16 | 5/8 | 1 | 232 | 91 | 13.5 | 8202 0404 16 |
| RUBAIR 20 | 3/4 | 1 | 232 | 159 | 17.2 | 8202 0405 20 |
| RUBAIR 25 | 1 | 1 1/3 | 232 | 265 | 26.0 | 8202 0406 25 |

^a With a safety factor of 5 at 68°F.

^b The pressure drop will be 3 psi on a hose length of 16 ft, including 2 nipples and at an inlet pressure of 101 psi.

SPI

ELASTIC HOSE FOR VERTICAL AND HORIZONTAL APPLICATIONS

SPI elastic spiral hose is ideal for air tools used at varying distances from a fixed air outlet. It is easily stretched and retracts immediately when released. When used with hand tools, its self-storage principle ensures that the hose is kept off the floor and out of the way of the operator. The SPI 1 and SPI 2 have ball bearing swivels fitted on the long hose side to allow 360° rotation. All spiral hoses, except the SPI4, are fitted with plastic spring guard. SPI is the ideal hose in combination with a balancer.

- Self-retractable.
- Light and flexible.
- Strong and durable.
- Tubing material: Polyurethane (100% PUR).
- Hardness: Shore A 98 +2.
- Colour: Blue.
- Working pressure: 116 psi at 73°F.
- Burst pressure: 363 psi at 73°F.
- Temperature range: -40°F to +158°F.



Dimensions

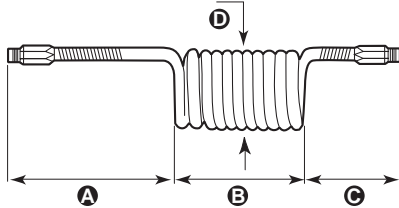

| Model | Hose inside dia in | Hose outside dia in | Max. rec. air flow ^a cfm | Working range ft | Length | | | Max spiral dia (D) ft | Male threads in NPT | Ordering No. |
|--------------|--------------------|---------------------|-------------------------------------|------------------|--------|--------|--------|-----------------------|---------------------|--------------|
| | | | | | (A) in | (B) in | (C) in | | | |
| SPI 1SPSW-M | 1/4 | 3/8 | 10 | 13 | 19 1/2 | 13 | 6 | 2 | 1/4 | 8202 0508 91 |
| SPI 2SPSW-M | 5/16 | 1/2 | 21 | 13 | 19 1/2 | 10 1/2 | 6 | 2 3/4 | 3/8 | 8202 0508 92 |
| SPI 2SPSW-L | 5/16 | 1/2 | 19 | 20 | 19 1/2 | 17 | 6 | 2 3/4 | 3/8 | 8202 0508 93 |
| SPI 2SPSW-XL | 5/16 | 1/2 | 13 | 26 | 19 1/2 | 23 1/2 | 6 | 2 3/4 | 3/8 | 8202 0508 94 |
| SPI 3SP-M | 7/16 | 5/8 | 47 | 13 | 19 1/2 | 10 | 6 | 4 | 3/8 | 8202 0508 95 |
| SPI 3SP-L | 7/16 | 5/8 | 36 | 20 | 19 1/2 | 15 1/2 | 6 | 4 | 3/8 | 8202 0508 96 |
| SPI 3SP-XL | 7/16 | 5/8 | 28 | 26 | 19 1/2 | 21 1/2 | 6 | 4 | 3/8 | 8202 0508 97 |
| SPI 4SP-L | 1/2 | 3/4 | 57 | 20 | 19 1/2 | 40 1/3 | 6 | 4 1/2 | 1/2 | 8202 0508 98 |
| SPI 4SP-XXL | 1/2 | 3/4 | 45 | 33 | 19 1/2 | 33 1/2 | 20 | 4 1/2 | 1/2 | 8202 0508 99 |

^a At inlet pressure 87 psi and pressure drop 7 psi. Teflon coating on NPT threads.

Productivity Kits

Productivity kits boost productivity, extend tool lifetime and ensure minimum pressure drop.

Each productivity kit includes ball valve, air preparation unit, and the couplings, hose and nipples needed for correct and safe installation of the tool.

Just choose the correct productivity kit based on the air flow requirement of the tool and whether the tool needs lubrication or not. You'll be surprised how much the productivity kit improves the performance of the tool.

- Improves the performance of the tool.
- Fast and easy installation.
- Extends tool lifetime.



PRODUCTIVITY KITS FOR SCREWDRIVERS, DRILLS AND GRINDERS

| Model | Max air flow | Hose 16.4 ft | Coupling | Lubrication | Ordering No. |
|--|--------------|--------------|--------------|-------------|--------------|
| For small screwdrivers and small drills | | | | | |
| MIDI Optimizer F/R EQ08US-C06 | 12 cfm | Cablaire 06 | ErgoQIC 08US | No | 8202 0850 21 |
| MIDI Optimizer F/RD EQ08US-C06 | 19 cfm | Cablaire 06 | ErgoQIC 08US | Yes | 8202 0850 22 |
| For screwdrivers and drills | | | | | |
| MIDI Optimizer F/RD EQ08US-C08 | 19 cfm | Cablaire 08 | ErgoQIC 08US | Yes | 8202 0850 23 |
| MIDI Optimizer F/R EQ08US-C08 | 19 cfm | Cablaire 08 | ErgoQIC 08US | No | 8202 0850 24 |
| For 1/2" drills and small nutrunners | | | | | |
| MIDI Optimizer F/RD EQ10US-C10 | 34 cfm | Cablaire 10 | ErgoQIC 10US | Yes | 8202 0850 25 |
| MIDI Optimizer F/RD EQ10US-R10 | 34 cfm | Rubber 10 | ErgoQIC 10US | Yes | 8202 0850 26 |
| For drills and nutrunners | | | | | |
| MIDI Optimizer F/RD EQ10US-C13 | 50 cfm | Cablaire 13 | ErgoQIC 10US | Yes | 8202 0850 27 |
| MIDI Optimizer F/RD EQ10US-R13 | 50 cfm | Rubber 13 | ErgoQIC 10US | Yes | 8202 0850 28 |
| For grinders, percussive tools and nutrunners | | | | | |
| MIDI Optimizer F/RD EQ10US-T13 | 65 cfm | Turbo 13 | ErgoQIC 10US | Yes | 8202 0850 29 |
| MIDI Optimizer F/R EQ10US-T13 | 65 cfm | Turbo 13 | ErgoQIC 10US | No | 8202 0850 30 |
| For large grinders | | | | | |
| MIDI Optimizer F/RD EQ15US-T16 | 85 cfm | Turbo 16 | ErgoQIC 15US | Yes | 8202 0850 31 |
| MAXI F/R EQ15US-T20 | 140 cfm | Turbo 20 | ErgoQIC 15US | No | 8202 0850 32 |
| MAXI F/RD EQ15US-T20 | 140 cfm | Turbo 20 | ErgoQIC 15US | Yes | 8202 0850 33 |

NOTE: Tool nipple is not included in the Productivity kit and needs to be order separately together with the tool.

PRODUCTIVITY KITS FOR IMPACT WRENCHES AND PULSE TOOLS

| Model | Max air flow | Hose 16.4 ft | Coupling | Lubrication | Ordering No. |
|--|--------------|--------------|--------------|-------------|--------------|
| For small impact wrenches and pulse tools | | | | | |
| MIDI Optimizer F/RD EP EQ08US-C08 | 19 cfm | Cablaire 08 | ErgoQIC 08US | Yes | 8202 0850 45 |
| For 1/2" impact wrenches and pulse tools | | | | | |
| MIDI Optimizer F/RD EP EQ10US-C10 | 34 cfm | Cablaire 10 | ErgoQIC 10US | Yes | 8202 0850 46 |
| For impact wrenches and pulse tools | | | | | |
| MIDI Optimizer F/RD EP EQ10US-C13 | 50 cfm | Cablaire 13 | ErgoQIC 10US | Yes | 8202 0850 47 |
| MIDI Optimizer F/RD EP EQ10US-T13 | 65 cfm | Turbo 13 | ErgoQIC 10US | Yes | 8202 0850 48 |

NOTE: Tool nipple is not included in the Productivity kit and needs to be order separately together with the tool.

PRE-MOUNTED HOSE KITS

Atlas Copco hose kits provides an easy way to choose the right hose and coupling combination for pneumatic tools. Each kit is ready for immediate use without the need of assembly tools.

- Correct combination hose – coupling.
- Leak free hose connections.
- Immediate use.



HOSE KITS

| Hose | Dia in | Length ft | Nipple | Coupling | Air inlet thread nipple, NPT | Ordering No. |
|----------|--------|-----------|------------|--------------|------------------------------|--------------|
| Cablaire | 1/4 | 16 | ErgoNIP 08 | ErgoQIC 08 | - | 8202 1182 01 |
| Cablaire | 1/4 | 16 | NIP 08 | ErgoQIC 08US | - | 8202 1182 16 |
| Cablaire | 5/16 | 16 | NIP 08 | ErgoQIC 08US | - | 8202 1182 21 |
| Cablaire | 3/8 | 16 | ErgoNIP 10 | ErgoQIC 10 | - | 8202 1182 05 |
| Cablaire | 3/8 | 16 | ErgoNIP 10 | ErgoQIC 08 | 1/4 | 8202 1180 10 |
| Cablaire | 3/8 | 16 | NIP 10US | ErgoQIC 10US | - | 8202 1182 17 |
| Cablaire | 3/8 | 32 | ErgoNIP 10 | ErgoQIC 08 | 1/4 | 8202 1180 13 |
| Cablaire | 1/2 | 16 | ErgoNIP 10 | ErgoQIC 10 | - | 8202 1182 10 |
| Cablaire | 1/2 | 16 | ErgoNIP 10 | ErgoQIC 08 | 1/4 | 8202 1180 11 |
| Cablaire | 1/2 | 16 | ErgoNIP 10 | ErgoQIC 10 | 3/8 | 8202 1180 12 |
| Cablaire | 1/2 | 16 | NIP 10US | ErgoQIC 10US | - | 8202 1182 18 |
| Cablaire | 1/2 | 28 | ErgoNIP 10 | ErgoQIC 10 | - | 8202 1182 20 |
| Cablaire | 1/2 | 32 | ErgoNIP 10 | ErgoQIC 08 | 1/4 | 8202 1180 14 |
| Cablaire | 1/2 | 32 | ErgoNIP 10 | ErgoQIC 10 | 3/8 | 8202 1180 15 |
| Rubber | 3/8 | 16 | NIP 10US | ErgoQIC 10US | - | 8202 1182 23 |
| Rubber | 1/2 | 16 | NIP 10US | ErgoQIC 10US | - | 8202 1182 24 |
| Turbo | 1/2 | 16 | NIP 10US | ErgoQIC 10US | - | 8202 1182 19 |
| Turbo | 5/8 | 16 | ErgoNIP 10 | ErgoQIC 10 | - | 8202 1180 34 |
| Turbo | 5/8 | 16 | NIP 15US | ErgoQIC 15US | - | 8202 1182 22 |
| Turbo | 5/8 | 32 | ErgoNIP 10 | ErgoQIC 10 | - | 8202 1180 46 |

HM LIGHT

The HM Light has a robust design with a high impact composite casing. The outlet slot is optimized to provide an ideal pull-out angle for the hose. The HM Light is recommended for small and medium screwdrivers, small and medium pulse tools, small drills, impact wrenches up to 1/2" size and riveting and chipping hammers.

- Snap-on, pivoting wall bracket
- PVC/PUR hose
- Hose end provided with pressed fitting and steel spiral hose protector (NPT and BSP)
- Hose easily replaced when needed
- Drum with ball bearings on both sides
- Working temperature: +32°F - +122°F
- Inlet hose length: 3.3 ft.



| Model | Hose length ft | Hose type | Hose inside dia | | Connection inlet hose inside dia (cut of hose) in | Connection distribution hose NPT | Economical air flow (at 3 psi pressure drop) cfm | Max air flow capacity (at 7 psi pressure drop) cfm | Weight | |
|----------------|-------------------|-----------|-----------------|------|--|-------------------------------------|---|---|--------|--------------|
| | | | mm | in | | | | | lb | Ordering No. |
| HM LIGHT 8-8 | 26 | PVC/PUR | 8 | 5/16 | 3/8 | 1/4 male thread | 8 | 15 | 9 | 8202 1183 41 |
| HM LIGHT 8-12 | 39 | PVC/PUR | 8 | 5/16 | 3/8 | 1/4 male thread | 6 | 11 | 14 | 8202 1183 42 |
| HM LIGHT 10-10 | 33 | PVC/PUR | 10 | 3/8 | 3/8 | 3/8 male thread | 13 | 21 | 12 | 8202 1183 43 |

Dimensions

HM LIGHT 8-8 (8-12)

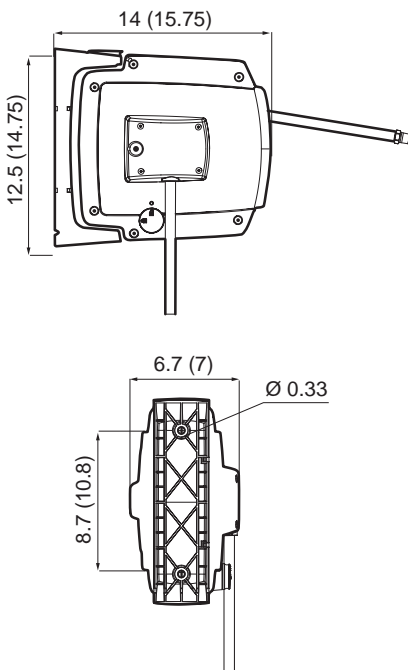

FLOW CHART.

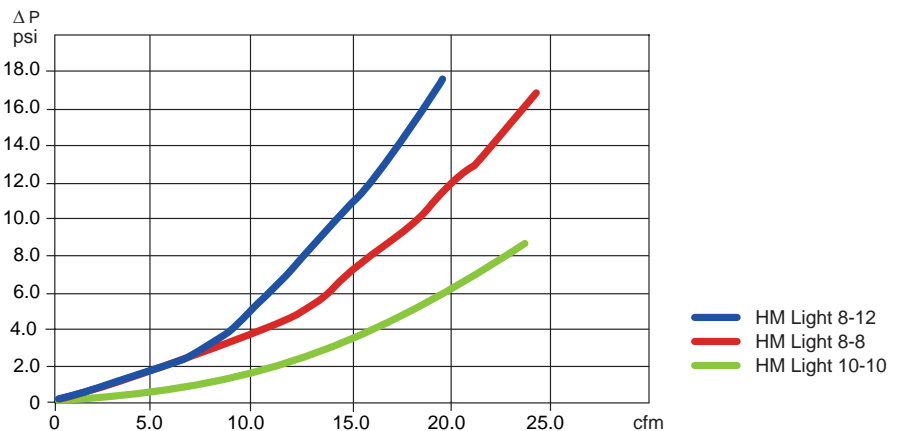

HM OPEN

The HM Open has an open composite casing and 10 mm or 13 mm hose. HM Open is a reliable, medium sized hose reel recommended for screwdrivers, impact wrenches, pulse tools, drills, chipping and riveting hammers and grinders up to 1000 W.

- Rubber hose
- Outlet roller position can be adjusted through 120 degrees for optimal pull-out angle
- Hose end provided with steel spiral hose protector (NPT and BSP)
- Latch function is easily disengaged
- Spring tension is easily adjusted
- Floor, wall or ceiling mounting
- Working temperature: +14°F - +140°F
- Inlet hose length: 3.3 ft.



| Model | Hose length ft | Hose type | Hose inside dia | | Connection inlet hose inside dia (cut of hose) | | Connection distribution hose NPT | Economical air flow (at 3 psi pressure drop) cfm | Max air flow capacity (at 7 psi pressure drop) cfm | Weight lb | Ordering No. |
|---------------|-------------------|-----------|-----------------|-----|--|-----------------|----------------------------------|---|---|--------------|--------------|
| | | | mm | in | mm | in | | | | | |
| HM OPEN 10-15 | 49 | Rubber | 10 | 3/8 | 1/2 | 3/8 male thread | 11 | 19 | 30 | 8202 1183 44 | |
| HM OPEN 10-20 | 66 | Rubber | 10 | 3/8 | 1/2 | 3/8 male thread | 11 | 15 | 36 | 8202 1183 45 | |
| HM OPEN 12-10 | 33 | Rubber | 12.5 | 1/2 | 1/2 | 1/2 male thread | 28 | 47 | 32 | 8202 1183 46 | |
| HM OPEN 12-15 | 49 | Rubber | 12.5 | 1/2 | 1/2 | 1/2 male thread | 23 | 36 | 35 | 8202 1183 47 | |

Pivoting wall brackets needs to be ordered separately.

Dimensions

HM OPEN 12-10 (12-15)

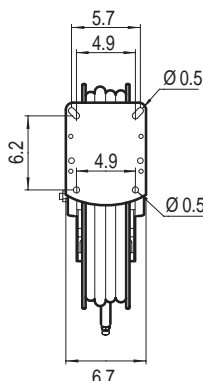
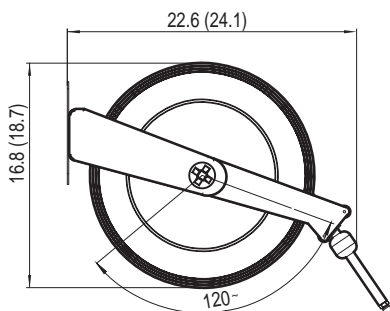

FLOW CHART.

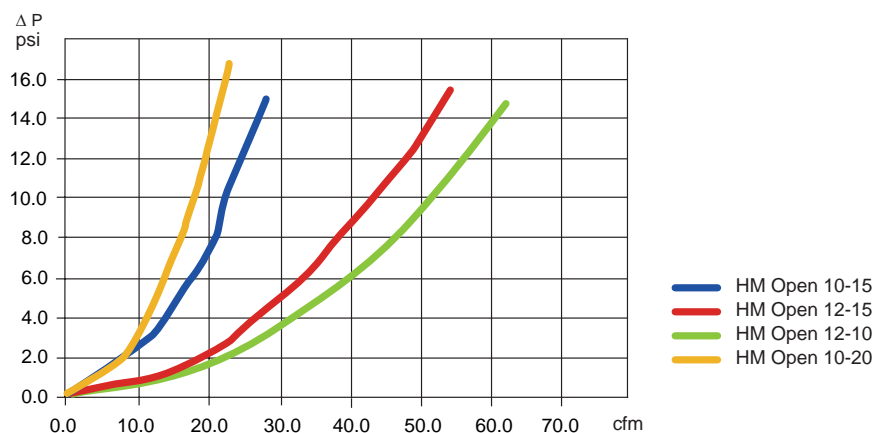

Accessories

| | Ordering No. |
|-----------------------|--------------|
| Pivoting wall bracket | 4390 2080 10 |

HM OPEN FLEX

Hose reels in the HM Open Flex series have an open steel casing and 3/8" or 1/2" hose. HM Open Flex hose reels are recommended for screwdrivers, impact wrenches, pulse tools, drills, chipping and riveting hammers and grinders up to 1.3 hp.

- Kink resistant PUR hose or spatter resistant rubber hose.
- Floor, wall or ceiling mounting.
- Revolving hinge for flexible use.
- Working temperature: -22°F to +140°F.
- Max working pressure: 290 psi.
- Inlet hose length: 5 ft.



| Model | Hose length ft | Hose type | Hose inside dia | | Connection inlet hose inside dia (cut of hose) in | Connection distribution hose NPT | Economical air flow (at 3 psi pressure drop) cfm | Max air flow capacity (at 7 psi pressure drop) cfm | Weight | |
|------------------|-------------------|-----------|-----------------|-----|--|----------------------------------|---|---|--------|--------------|
| | | | mm | in | | | | | lb | Ordering No. |
| HM OPEN XL 12-20 | 66 | Rubber | 12.5 | 1/2 | 1/2 | 1/2 male thread | 17 | 30 | 72 | 8202 1183 48 |
| HM OPEN XL 12-30 | 98 | Rubber | 12.5 | 1/2 | 1/2 | 1/2 male thread | 17 | 25 | 74 | 8202 1183 49 |
| HM OPEN XL 19-15 | 49 | Rubber | 19 | 3/4 | 3/4 | 3/4 male thread | 57 | 93 | 76 | 8202 1183 50 |
| HM OPEN XL 25-10 | 33 | Rubber | 25 | 1 | 1 | 1 male thread | 127 | 201 | 81 | 8202 1183 51 |

Pivoting wall brackets needs to be ordered separately.

Dimensions

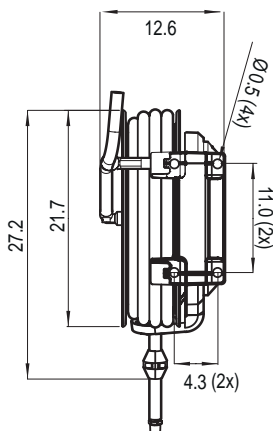
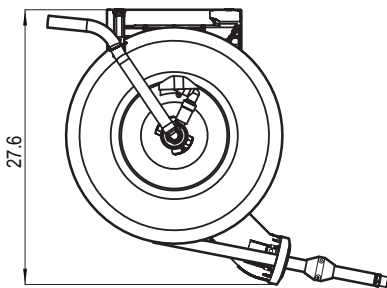

FLOW CHART.

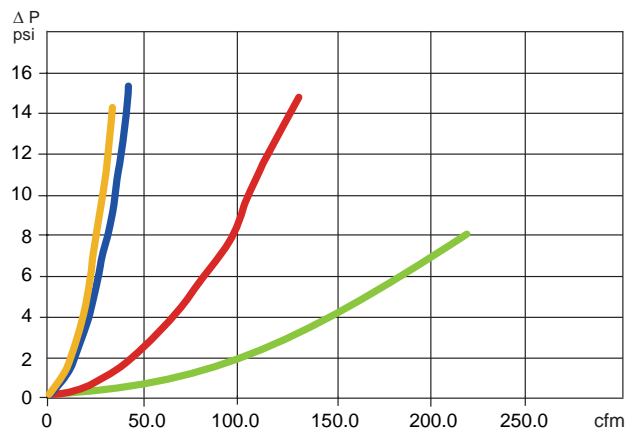

Accessories

| | Ordering No. |
|-----------------------|--------------|
| Pivoting wall bracket | 4390 2080 11 |

HOSE REEL BALANCER – HRIL

Models in the HRIL range of hose reel balancers are specifically designed for use with small pneumatic hand tools.

The integrated air hose and support cable ensure the work area is kept tidy and the tool is easy to control.

- Ergonomics – The retraction force over hose travel remains almost constant which minimizes load on the operator and ensures smooth operation.
- An easily adjusted rubber stop is fitted on the hose which allows the tool to be set at the optimum position.
- The retraction force is easily adjustable by means of a hand wheel on the rear casing (this can be removed if desired, once the retraction force is set).
- Long service life – The design features a rugged casing, self lubricating spindle bearing bushes and a 360 degrees rotary inlet connector.
- A durable hose is fitted with additional protection to prevent excessive bending around air connectors.
- Low pressure drop – The HRIL balancers have very good flow characteristics.



| Model | Capacity range | | Max rec. air flow ^a cfm | Hose travel ft | Weight | | Max working pressure psi | Dimensions | | | Ordering No. |
|--------|----------------|---------|---------------------------------------|-------------------|--------|-----|-----------------------------|------------|---------|---------|--------------|
| | kg | lb | | | kg | lb | | A in | B in | C in | |
| HRIL 3 | 0.5-1.4 | 1.1-3.1 | 11.7 | 3.3 | 1.2 | 2.6 | 147 | 3.6 | 5.2 | 6.8 | 8202 0601 10 |
| HRIL 4 | 0.7-2.0 | 1.5-4.4 | 13.8 | 3.3 | 1.4 | 3.1 | 147 | 3.6 | 5.2 | 6.8 | 8202 0601 28 |

^a At inlet pressure of 86 psi pressure drop is 5.7 psi.

Dimensions

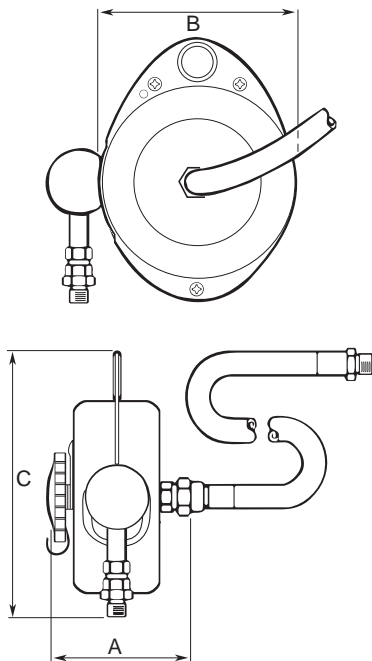

AIR LINE FITTINGS

All models have a NPT 1/4" inlet fitting.

HRIL 3 supplied with NPT 1/8" and NPT 1/4" outlet fittings.

HRIL 4 supplied with NPT 1/4" outlet fitting.

Optional Accessories

| Designation | Ordering No. |
|--------------|--------------|
| Safety chain | 4391 4045 90 |

COLIBRI – COL

Balancers in the unique COL range hold the load and keep it weightless throughout the entire cable length.

PRODUCTIVITY

COL balancers always hold the tool in the correct position.

ERGONOMIC

COL balancers reduce the stress level in the operator's muscles.

SAFETY

The load is not pulled back when released and the surroundings are protected from accidental hoisting of the load.

The cable locks in the event of spring failure (downward braking power).

In all models the braking function can be activated upwards by using the "bow and arrow" principle if you need to slacken the cable to change the tool.



Dimensions

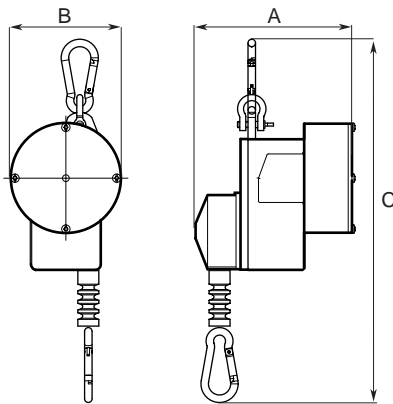

COLIBRI STANDARD

| Model | Capacity range | | Cable length ft | Weight | | Dimensions | | | Ordering No. |
|----------|----------------|----------|--------------------|--------|-----|------------|---------|---------|--------------|
| | kg | lb | | kg | lb | A in | B in | C in | |
| COL 1 01 | 0.7- 1.3 | 1.5- 2.9 | 5.6 | 0.5 | 1.1 | 4.3 | 2.8 | 9.6 | 8202 0750 01 |
| COL 1 02 | 1.0- 2.0 | 2.2- 4.4 | 1.7 | 0.5 | 1.1 | 4.3 | 2.8 | 9.6 | 8202 0750 19 |

NOTE: COL 1 01 comes with nylon cable.

Optional Accessories

SAFETY CHAIN

| | Ordering No. |
|-------|--------------|
| COL 1 | 4391 4045 90 |

RIL BALANCER

RIL balancers always keep the tool in place, handy and easily accessible. RIL balancers are available as retractors or weightless positioning balancers.

RIL RETRACTORS

- Adjustable wire stop.
- High quality spring and construction.
- Load range 0 to 22 lb.



Dimensions

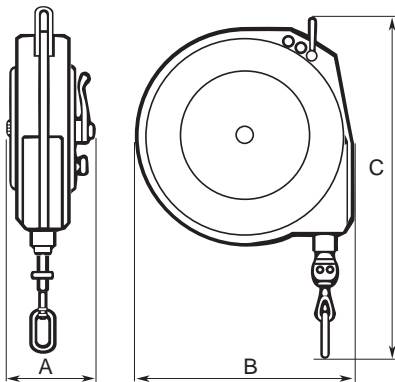

RIL – STANDARD DESIGN

| Model | Capacity range | | Cable length ft | Weight | | Dimensions | | | Ordering No. |
|-----------------------|----------------|-----------|--------------------|--------|-----|------------|---------|---------|--------------|
| | kg | lb | | kg | lb | A in | B in | C in | |
| RIL 1C | 0.0- 0.5 | 0.0- 1.7 | 4.9 | 0.6 | 1.3 | 2.0 | 4.2 | 9.4 | 8202 0700 02 |
| RIL 2C | 0.4- 1.0 | 0.9- 2.2 | 4.9 | 0.6 | 1.3 | 2.0 | 4.2 | 9.4 | 8202 0701 19 |
| RIL 4C | 1.0- 2.0 | 2.2- 4.4 | 4.9 | 0.6 | 1.3 | 2.0 | 4.2 | 9.4 | 8202 0702 18 |
| RIL 5C | 1.4- 2.3 | 3.1- 5.1 | 4.9 | 0.6 | 1.3 | 2.0 | 4.2 | 9.4 | 8202 0703 25 |
| RIL 5 | 0.4- 2.3 | 0.9- 5.1 | 7.9 | 2.0 | 4.4 | 2.8 | 6.2 | 12.1 | 8202 0703 09 |
| RIL 5LR ^b | 0.4- 2.3 | 0.9- 5.1 | 7.9 | 2.0 | 4.4 | 2.8 | 6.2 | 12.1 | 8202 0703 15 |
| RIL 10C | 2.0- 5.0 | 4.4-11.0 | 7.9 | 2.7 | 6.0 | 3.3 | 7.5 | 14.5 | 8202 0704 16 |
| RIL 10CS | 2.0- 5.0 | 4.4-11.0 | 7.9 | 2.7 | 6.0 | 3.3 | 7.5 | 14.5 | 8202 0704 20 |
| RIL 15C | 5.0- 7.0 | 11.0-15.4 | 7.9 | 3.2 | 7.1 | 3.3 | 7.5 | 14.5 | 8202 0705 15 |
| RIL 15CS ^a | 5.0- 7.0 | 11.0-15.4 | 7.9 | 3.2 | 7.1 | 3.3 | 7.5 | 14.5 | 8202 0705 20 |
| RIL 22C | 6.0-10.0 | 13.2-22.0 | 7.9 | 3.2 | 7.1 | 3.3 | 7.5 | 14.5 | 8202 0706 14 |
| RIL 22CS ^a | 6.0-10.0 | 13.2-22.0 | 7.9 | 3.2 | 7.1 | 3.3 | 7.5 | 14.5 | 8202 0706 20 |

^a Balancer equipped with automatic safety drum lock in case of spring failure.

^b Contains a lock ratchet to lock the cable in increments along its entire length.

NOTE: RIL 1C, 2C, 4C and 5C comes with nylon cable. All other models are equipped with steel wire.

Optional Accessories

SAFETY CHAIN

| | Ordering No. |
|--|--------------|
| 1C, 2C, 4C and 5C | 4391 4045 90 |
| 10C ^a , 15C ^a and 22C ^a | 4391 4156 00 |
| 5 | 4391 4046 90 |

^a Safety chain included.

WP BALANCER

Weightless positioning balancers with a cone-shaped drum hold the load and keep it weightless throughout the entire cable length. The casing for WP 05/10 are in plastic, the WP 20 in aluminium and the WP 30/40 models are in abrasion resistant aluminium.

All models except for the WP 20 comes with a swiveling safety hook.

PRODUCTIVITY

The WP balancers always hold the tool in the correct position and minimize worker fatigue.

ERGONOMIC

The WP balancers reduce stress level in the operators muscles.

SAFETY

The load is not pulled back when released and the environment is protected from accidental hoisting of the load.

- Steel cable with cable stop buffer.
- Safety chain.
- Quick and easy cable replacement.



Dimensions

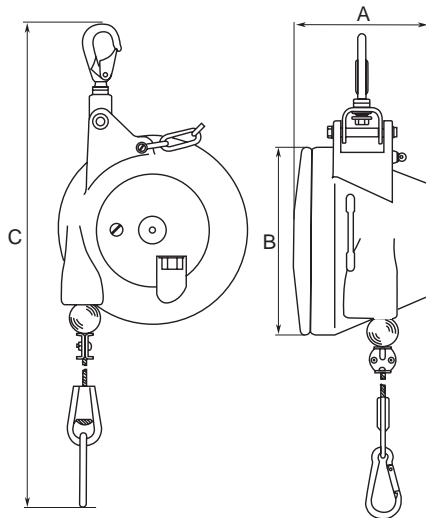

| Model | Capacity range | | Cable length ft | Weight | | Dimension in | | | Ordering No. |
|-----------------------------------|----------------|-----------|--------------------|--------|------|--------------|---------|---------|--------------|
| | kg | lb | | kg | lb | A in | B in | C in | |
| WP 05 - Standard | | | | | | | | | |
| WP 05-1 | 0.4-1.2 | 0.9-2.6 | 6.5 | 1.3 | 2.9 | 2.8 | 5.6 | 18.1 | 8202 0778 00 |
| WP 05-3 | 1.2-2.6 | 2.6-5.7 | 6.5 | 1.4 | 3.1 | 2.8 | 5.6 | 18.1 | 8202 0778 01 |
| WP 05-4 | 2.6-3.8 | 5.7-8.4 | 6.5 | 1.5 | 3.3 | 2.8 | 5.6 | 18.1 | 8202 0778 02 |
| WP 05-5 | 3.8-5.2 | 8.4-11.5 | 6.5 | 1.5 | 3.3 | 2.8 | 5.6 | 18.1 | 8202 0778 03 |
| WP 05-6 | 5.2-6.5 | 11.5-14.3 | 6.5 | 1.5 | 3.3 | 2.8 | 5.6 | 18.1 | 8202 0778 04 |
| WP 05 - Extended Cable - A | | | | | | | | | |
| WP 05-1-A | 0.4-1.2 | 0.9-2.6 | 18 | 1.3 | 2.9 | 2.8 | 5.6 | 18.1 | 8202 0778 05 |
| WP 05-3-A | 1.2-2.6 | 2.6-5.7 | 18 | 1.4 | 3.1 | 2.8 | 5.6 | 18.1 | 8202 0778 06 |
| WP 05-4-A | 2.6-3.8 | 5.7-8.4 | 18 | 1.5 | 3.3 | 2.8 | 5.6 | 18.1 | 8202 0778 07 |
| WP 05-5-A | 3.8-5.2 | 8.4-11.5 | 18 | 1.5 | 3.3 | 2.8 | 5.6 | 18.1 | 8202 0778 08 |
| WP 05-6-A | 5.2-6.5 | 11.5-14.3 | 18 | 1.5 | 3.3 | 2.8 | 5.6 | 18.1 | 8202 0778 09 |
| WP 10 - Standard | | | | | | | | | |
| WP 10-3 | 3-5 | 6.6-11 | 6.5 | 2.9 | 6.4 | 5.1 | 7.4 | 20.5 | 8202 0779 00 |
| WP 10-4.5 | 4.5-7 | 10-15.4 | 6.5 | 3.1 | 6.8 | 5.1 | 7.4 | 20.5 | 8202 0779 01 |
| WP 10-6 | 6-10 | 13-22 | 6.5 | 3.2 | 7.0 | 5.1 | 7.4 | 20.5 | 8202 0779 02 |
| WP 10-9 | 9-14 | 20-31 | 6.5 | 3.4 | 7.5 | 5.1 | 7.4 | 20.5 | 8202 0779 03 |
| WP 10-13 | 13-17 | 29-37 | 6.5 | 3.6 | 8.0 | 5.1 | 7.4 | 20.5 | 8202 0779 04 |
| WP 10-16 | 16-21 | 35-46 | 6.5 | 3.8 | 8.4 | 5.1 | 7.4 | 20.5 | 8202 0779 05 |
| WP 10 - Extended Cable - A | | | | | | | | | |
| WP 10-3-A | 3-5 | 6.6-11 | 18 | 2.9 | 6.4 | 5.1 | 7.4 | 20.5 | 8202 0779 06 |
| WP 10-4.5-A | 4.5-7 | 10-15.4 | 18 | 3.1 | 6.8 | 5.1 | 7.4 | 20.5 | 8202 0779 07 |
| WP 10-6-A | 6-10 | 13-22 | 18 | 3.2 | 7.0 | 5.1 | 7.4 | 20.5 | 8202 0779 08 |
| WP 10-9-A | 9-14 | 20-31 | 18 | 3.4 | 7.5 | 5.1 | 7.4 | 20.5 | 8202 0779 09 |
| WP 10-13-A | 13-17 | 29-37 | 18 | 3.6 | 8.0 | 5.1 | 7.4 | 20.5 | 8202 0779 10 |
| WP 10-16-A | 16-21 | 35-46 | 18 | 3.8 | 8.4 | 5.1 | 7.4 | 20.5 | 8202 0779 11 |
| WP 20 - Standard | | | | | | | | | |
| WP 20-15 | 15-25 | 33-55 | 6.5 | 7.8 | 17.2 | 6 | 8.6 | 20.5 | 8202 0780 00 |
| WP 20-25 | 25-35 | 55-77 | 6.5 | 8.9 | 19.6 | 6 | 8.6 | 20.5 | 8202 0780 01 |
| WP 20-35 | 35-45 | 77-99 | 6.5 | 9.5 | 21.0 | 6 | 8.6 | 20.5 | 8202 0780 02 |
| WP 20-45 | 45-55 | 99-121 | 6.5 | 9.8 | 21.5 | 6 | 8.6 | 20.5 | 8202 0780 03 |
| WP 30 - Standard | | | | | | | | | |
| WP 30-12 | 12-20 | 26-44 | 6.5 | 14.8 | 32.6 | 8 | 11.2 | 29.5 | 8202 0781 00 |
| WP 30-20 | 20-30 | 44-66 | 6.5 | 15.2 | 33.5 | 8 | 11.2 | 29.5 | 8202 0781 01 |
| WP 30-30 | 30-45 | 66-99 | 6.5 | 16.9 | 37.3 | 8 | 11.2 | 29.5 | 8202 0781 02 |
| WP 30-45 | 45-60 | 99-132 | 6.5 | 17.3 | 38.1 | 8 | 11.2 | 29.5 | 8202 0781 03 |
| WP 30-60 | 60-75 | 132-165 | 6.5 | 18.7 | 41.2 | 8 | 11.2 | 29.5 | 8202 0781 04 |
| WP 30-75 | 75-90 | 165-198 | 6.5 | 19.7 | 43.4 | 8 | 11.2 | 29.5 | 8202 0781 05 |
| WP 30-90 | 90-100 | 198-220 | 6.5 | 19.9 | 43.4 | 8 | 11.2 | 29.5 | 8202 0781 06 |
| WP 40 - Standard | | | | | | | | | |
| WP 40-100 | 100-115 | 220-254 | 10 | 42.0 | 43.9 | 13.7 | 12.6 | 31.5 | 8202 0782 00 |
| WP 40-115 | 115-130 | 254-287 | 10 | 44.0 | 97.0 | 13.7 | 12.6 | 31.5 | 8202 0782 01 |
| WP 40-130 | 130-140 | 287-309 | 10 | 46.0 | 101 | 13.7 | 12.6 | 31.5 | 8202 0782 02 |
| WP 40-140 | 140-150 | 309-331 | 10 | 48.0 | 106 | 13.7 | 12.6 | 31.5 | 8202 0782 03 |

BLOW GUN BG-SERIES

Atlas Copco blow guns BG-series are hard wearing, user friendly solution for all cleaning applications. The plastic body offer flexibility in handling for both left and right handed users, it insulate against cold and it reduce the risk of scratches to worksurfaces. The blow gun has excellent throtteling properties allowing easy regulation of the air flow. The blow guns have air inlet thread in brass that is fully covered by the plastic body. The blowguns are with star tip to reduce risk of damages or injuries if the tube is pressed against workpiece or skin and is therefore in compliance with the OSHA Safety Standards.

- High flow capacity
- Suspension
- Plastic body to avoid scratches
- Air inlet thread in brass
- Star tip, OSHA Safety Standards



| Model | Version | Working pressure psi | Air flow cfm | Weight | | Air inlet thread NPT | Ordering No. |
|----------------|-------------------------------|-------------------------|-----------------|--------|------|-------------------------|--------------|
| | | | | kg | lb | | |
| BG 2605-STSS U | Short tube, star tip | 91 | 14 | 0.12 | 0.26 | 1/4 | 8202 1006 08 |
| BG 2606-STSS U | Long tube, star tip, silencer | 91 | 13 | 0.14 | 0.31 | 1/4 | 8202 1006 09 |

Test Equipment

AIR LEAKAGE DETECTOR

The air leakage detector is used to find leaks (e.g. in compressed air installations, vacuum installations, etc.) It works by "listening" on a frequency band normally containing no interference and non-audible for humans (>20kHz). Leaking compressed air or electrical flashover (sparks) generate, e.g. ultrasonic sound.

The equipment is delivered in a suitcase and consists of: Detecting device, headphone set and directional probe.

Ordering No. 8202 9002 00.



AIR MOTORS

Contents

| | |
|---------------------------|-----|
| Vane air motors | 327 |
| LZB vane air motors | 328 |
| LZL vane air motors..... | 328 |
| Air motor support..... | 329 |

Air motors from Atlas Copco – the reliable, cost-effective solution when applying power to rotating machines. Consider the air motor features and characteristics giving large benefits to the designer:

- Power-to-weight performance that is superior to most other motors, in fact, 75% lighter and 85% smaller than an asynchronous electric motor with the same output.
- Can be held stalled at full torque indefinitely, and accepts repeated starting and stopping without limitation.
- Torque, speed and direction of rotation can be changed easily using simple control methods.
- Output that automatically adjusts to match the applied load.
- Controllable over a wide speed range.
- Ideal for many applications in hazardous or hostile environments.
- Smooth start-up to minimize “shock” loading on transmission components.
- Unaffected by, and will not generate, electrical interference.



FEATURES FOR LZB MOTORS

Lubrication-free air motors for sensitive processes where hygienic operation is crucial

Equipped with low friction vanes and sealed bearings the lubrication-free motors release no lubricants into the air. They offer a viable drive solution for sensitive processes and hygienic environments where oil contamination would be at best a problem and, at worst, a catastrophe.

Stainless steel air motors for harsh and aggressive environments

The stainless steel air motors are ideal for harsh or even aggressive environments where hygiene is essential. They have a “clean” design with no pockets where dirt can collect. They are fitted with double shaft seals to prevent water from entering the gears. Lubrication-free versions are also available.

High torque air motors when a real workhorse is needed

Fitted with extra strong planetary gears the high torque air motors provide torques up to 680 Nm. The gears are dimensioned to stand being loaded at full stall torque indefinitely. Despite their strength the high torque air motors are compact compared to solutions with helical or worm gears. Lubrication-free versions are also available.

Customized air motors to your individual specifications

Whatever the requirement, Atlas Copco is always happy to help customers find solutions to their special needs. For OEMs, for instance, a customized air motor can be the most efficient solution when integrating an air motor into a machine or a tool. Special motors may have unique casings or mounting arrangements. They may utilize non-standard materials or surface coatings and be designed to achieve a specific output.

For more information on Atlas Copco vane motors visit our web site.

Explosion proof certified versions



Our air motors are available with explosion proof certification as standard, in compliance with the European Union's ATEX Directive on equipment for potentially explosive environments.

LZB

0.1 – 2.80 KW

The Atlas Copco LZB vane air motors are compact in design, light in weight and available in a variety of different gear ratios to meet a variety of speed requirements. They are particularly suited to be built into hand held machines and also many different types of industrial equipment. These data are a summary of our range; please consult our air motor catalogue or our website to choose the right one for you.



| Model | Max output | | Speed range at max output r/min | Torque range at max output | | Min start torque range | | Free speed r/min | No. of gear ratios | Motor diameter | |
|-----------------------|------------|------|------------------------------------|----------------------------|----------|------------------------|-----------|---------------------|--------------------|----------------|-----|
| | kW | hp | | Nm | ft lb | Nm | ft lb | | | mm | in |
| Non-reversible | | | | | | | | | | | |
| LZB14 | 0.16 | 0.21 | 320-9100 | 0.17-4.8 | 0.13-3.5 | 0.23-8.5 | 0.17-6.27 | 700-19500 | 5 | 27 | 1.1 |
| LZB22 | 0.27 | 0.36 | 210-9600 | 0.27-11.8 | 0.20-8.7 | 0.32-22 | 0.24-16.2 | 480-21500 | 7 | 36 | 1.4 |
| LZB33/34 | 0.39 | 0.52 | 10-9400 | 0.40-349 | 0.30-257 | 0.69-680 | 0.51-502 | 20-19000 | 17 | 42 | 1.7 |
| LZB42 | 0.71 | 0.95 | 23-10000 | 0.68-272 | 0.5-201 | 1.09-435 | 0.80-321 | 42-19000 | 12 | 46 | 1.8 |
| LZB46 | 0.84 | 1.13 | 25-10800 | 0.74-299 | 0.55-221 | 1.20-485 | 0.88-358 | 45-20000 | 12 | 46 | 1.8 |
| LZB54 | 1.20 | 1.61 | 70-10000 | 1.15-161 | 0.85-119 | 1.80-261 | 1.33-193 | 125-18000 | 10 | 60 | 2.4 |
| LZB66 | 1.87 | 2.51 | 55-8200 | 2.2-308 | 1.62-227 | 3.2-456 | 2.4-336 | 110-16000 | 10 | 60 | 2.4 |
| LZB77 | 2.80 | 3.75 | 80-1220 | 22-332 | 16-245 | 35-536 | 26-395 | 165-2600 | 7 | 100 | 3.9 |
| Reversible | | | | | | | | | | | |
| LZB14 | 0.11 | 0.15 | 250-7000 | 0.15-4.3 | 0.11-3.2 | 0.24-6.9 | 0.18-5.1 | 490-13000 | 5 | 27 | 1.1 |
| LZB22 | 0.16 | 0.21 | 5-7000 | 0.24-10.5 | 0.18-7.7 | 0.32-14 | 0.24-10.3 | 5-13100 | 9 | 36 | 1.4 |
| LZB33/34 | 0.25 | 0.34 | 7-7000 | 0.34-300 | 0.25-221 | 0.46-412 | 0.34-304 | 10-13300 | 21 | 42 | 1.6 |
| LZB42 | 0.53 | 0.71 | 19-8000 | 0.63-255 | 0.46-188 | 0.85-344 | 0.63-254 | 33-14200 | 12 | 46 | 1.8 |
| LZB46 | 0.63 | 0.84 | 20-8500 | 0.71-287 | 0.52-212 | 0.96-388 | 0.71-286 | 35-15800 | 12 | 46 | 1.8 |
| LZB54 | 0.82 | 1.10 | 47-6800 | 1.15-161 | 0.85-119 | 1.40-207 | 1.03-153 | 90-12000 | 10 | 60 | 2.4 |
| LZB66 | 1.46 | 1.96 | 50-7500 | 1.9-259 | 1.4-191 | 2.4-337 | 1.8-249 | 90-13500 | 10 | 60 | 2.4 |
| LZB77 | 2.40 | 3.22 | 80-1280 | 18-274 | 13.3-202 | 24-374 | 18-276 | 155-2300 | 7 | 100 | 3.9 |

The LZB14, LZB22 and LZB33 models are available in lubrication-free versions. LZB14, LZB22 and LZB33 can be obtained in a stainless steel version. The standard non-reversible motors have clockwise rotation but can also be obtained with anti-clockwise rotation.

LZL

1.7 – 6.5 KW

The Atlas Copco LZL vane motors are reversible air motors which have been designed to offer outstanding starting and low speed performance. These general purpose motors are powerful, durable and offer long service life.



| Model | Torque at 3000 r/min | | Power at 3000 r/min | | Stall torque | | Air consumption at 3000 r/min ^a | | Max allowed speed r/min | Weight | |
|---------|----------------------|-------|---------------------|------|--------------|-------|--|-----|----------------------------|--------|-----|
| | Nm | ft lb | kW | hp | Nm | ft lb | l/s | cfm | | kg | lb |
| LZL03 M | 1.3 | 0.95 | 0.41 | 0.55 | 3.3 | 2.4 | 16 | 34 | 3000 | 2.9 | 6.4 |
| LZL05 M | 2.0 | 1.5 | 0.63 | 0.84 | 5.8 | 4.3 | 25 | 52 | 3000 | 3.9 | 8.6 |

^aNote that the air consumption in a typical mixing application normally is less than 50% of the values in the table
LZL 03/05 available with IEC and Nema flange. LZL05 also available in stainless steel.

| Model | Max output | | Speed at max output r/min | Torque at max output | | Min start torque | | Max allowed speed r/min | No. of gear ratios |
|-------------------------------|------------|-----|------------------------------|----------------------|---------|------------------|----------|----------------------------|--------------------|
| | kW | hp | | Nm | ft lb | Nm | ft lb | | |
| Motor only | | | | | | | | | |
| LZL03 S | 1.7 | 2.5 | 7500 | 2.2 | 1.6 | 2.8 | 2.1 | 11000 | – |
| LZL05 S | 2.1 | 2.8 | 6300 | 3.1 | 2.3 | 4.8 | 3.5 | 9200 | – |
| LZL15 | 3.2 | 4.3 | 4500 | 6.8 | 5.0 | 10.9 | 8.0 | 7200 | – |
| LZL25 | 5.0 | 6.7 | 4000 | 12.0 | 8.8 | 18.0 | 13.2 | 6000 | – |
| LZL35 | 6.5 | 8.7 | 3100 | 20.0 | 14.7 | 32.0 | 23.6 | 5000 | – |
| With helical gear unit | | | | | | | | | |
| LZL05 a | 2.0 | 2.6 | 45-512 | 36-403 | 27-297 | 56-624 | 41-460 | 65-740 | 6 |
| LZL15 a | 3.0 | 4.1 | 26-389 | 74-1071 | 55-790 | 116-1668 | 86-1230 | 43-639 | 6 |
| LZL25 a | 4.8 | 6.4 | 25-370 | 128-1836 | 94-1354 | 192-2754 | 141-2031 | 36-531 | 6 |
| LZL35 a | 6.2 | 8.3 | 61-464 | 128-944 | 94-696 | 192-1417 | 141-1045 | 111-838 | 4 |

^a Not ATEX certified.

CUSTOMIZED AIR MOTORS TO YOUR INDIVIDUAL SPECIFICATIONS

Whatever the requirement, Atlas Copco is always happy to help customers find solutions to their special needs. For OEMs, for instance, a customized air motor can be the most efficient solution when integrating an air motor into a machine or tool.

Special motors may have unique casings or mounting arrangements. They may utilize non-standard materials or surface coatings and be designed to achieve a specific output.



SELECT YOUR AIR MOTOR IN 30 SECONDS!

Designed for Windows-based PCs, Atlas Copco has developed an Air Motor Selection Guide. It stores data on all of Atlas Copco's air motors.

The designer specifies the required torques and speed of the motor and within seconds the program chooses the optimum motor. It also supplies complete documentation with performance curves and motor data.

Visit <http://www.atlascopco.com/airmotors/> to access the program.



AIR MOTOR DRAWING LIBRARY

CAD-drawings of any of the hundreds of different Atlas Copco air motors are available to designers, just download (in both 2D and 3D formats) via Internet from Atlas Copco Drawing Library. These CAD-drawings can then be quickly and easily inserted into the designer's machine drawing.



WHEN MORE INFORMATION IS REQUIRED

For further information on Atlas Copco vane motors please ask for a copy of our Air Motor catalogue or browse to our Links and Downloads section on www.atlascopco.com to download the catalog.

HOISTS AND TROLLEYS



Atlas Copco



Atlas Copco

Contents

| | |
|-------------------|-----|
| Air hoists..... | 332 |
| Trolleys | 333 |
| Accessories | 334 |

2.5t

Explosion-proof operation and stepless control for a smoother safer lift

Atlas Copco air hoists and trolleys are the industry benchmark for fast, precise and reliable lifting of heavy loads – even in cramped and sometimes hostile industrial environments.



Compact and lightweight, they are easy to control, survive rough handling and provide heavyweight performance.

EXPLOSION PROOF FOR SAFE OPERATION

Our air hoists and trolleys are ideal for lift applications in hazardous environments. All are certified Explosion-proof, to stringent European standards, in compliance with the EU ATEX Directive. Available in six sizes, they offer lift capacities from 250 kg to 5 tons. Hoists are certified to level Ex II 2 GD ck T5 IIC T100°C and trolleys are certified to Ex II 2 GD c T5 IIB T100°C.

SIMPLE INSTALLATION

The trolleys are easy to install. The wheels are designed so that the trolley is equally suitable on both parallel and tapered I-beam section beams. The distance between the wheels is easily adjusted to suit the beam width by turning the suspension yoke.



Selection guide

AIR HOIST SELECTION PROGRAM

The fastest way to choose correct hoists and accessories is by using the Windows based computer program available on our website.

To order your hoist or trolley with accessories factory fitted, simply list all items required and add the
Ordering No. 8990 0001 00

EXAMPLE: To order a 500 kg hoist with motor driven trolley, four button five-metre long pendant control and a load chain for a ten-metre lift, send the following:

| Order to be sent | Comments |
|-------------------|---|
| 1 x 8451 1540 28 | LLA500 ATEX Hoist block |
| 11 x 4310 2293 00 | Load chain for hoist = Required height of lift + 0.5 m, (see technical data for LLA Hoists) |
| 1 x 8451 1520 14 | TLT1000-M-N Motor driven trolley |
| 1 x 4310 2263 90 | 4 button handle + hoist actuator |
| 5 x 4310 2310 96 | Hose set for 4 button pendant control |
| 1 x 8990 0001 00 | Instruction to assemble above items |

- **Precise and stepless speed control** – Through effective stepless control with excellent creep characteristics the LLA air hoists are fast to use over the entire speed range.
- **Heavy duty performance** – These air hoists can continually operate at maximum load with frequent start and stop cycles without risk of damage.
- **Elimination of load sink** – The patented brake mechanism eliminates load-sink when starting lifting, and automatically holds the load if the air supply fails.
- **Compact size** – The small dimensions make the LLA hoists easy to install, even in the most restricted space. Also the low weight means the hoists can easily be moved for maintenance or relocation purposes.
- **Lubrication free**



| Model | Max lifting capacity lb | Lifting speed at full load | | Chain drops qty | Weight excl chain | | Chain weight | | Required chain-length metre | Air consumption | | Hose size | | Air inlet thread BSP | Ordering No. |
|------------------------------|----------------------------|-------------------------------|--------|--------------------|----------------------|-------|-----------------|-------|-----------------------------------|-----------------|-----|-----------|-----|----------------------------|--------------|
| | | m/min | ft/min | | kg | lb | kg/m | lb/ft | | l/s | cfm | mm | in | | |
| LLA250-L ATEX ^a | 550 | 18.6 | 61.0 | 1 | 12.7 | 28.0 | 0.9 | 0.6 | Lifting height + 0.5 | 37 | 78 | 12.5 | 1/2 | 1/2 | 8451 1550 17 |
| LLA500-L ATEX ^a | 1100 | 12.6 | 41.3 | 1 | 12.7 | 28.0 | 0.9 | 0.6 | Lifting height + 0.5 | 38 | 81 | 12.5 | 1/2 | 1/2 | 8451 1550 25 |
| LLA500-L-W ATEX ^c | 1100 | 12.6 | 41.3 | 1 | 12.7 | 28.0 | 0.9 | 0.6 | Lifting height + 0.5 | 38 | 81 | 12.5 | 1/2 | 1/2 | 8451 1540 93 |
| LLA980-L ATEX ^a | 2160 | 6.3 | 20.7 | 2 | 14.5 | 32.0 | 0.9 | 0.6 | 2 x Lifting height + 0.5 | 38 | 81 | 12.5 | 1/2 | 1/2 | 8451 1550 15 |
| LLA1000-L ATEX ^b | 2200 | 6.3 | 20.7 | 2 | 15.0 | 32.0 | 0.9 | 0.6 | 2 x Lifting height + 0.5 | 38 | 81 | 12.5 | 1/2 | 1/2 | 8451 1550 32 |
| LLA2500-L ATEX ^b | 5500 | 3.2 | 10.5 | 1 | 42.5 | 93.7 | 2.9 | 1.9 | Lifting height + 0.6 | 40 | 85 | 12.5 | 1/2 | 1/2 | 8451 1550 41 |
| LLA3000-L ATEX ^a | 6000 | 3.2 | 10.5 | 1 | 42.5 | 93.7 | 2.9 | 1.9 | Lifting height + 0.6 | 40 | 85 | 12.5 | 1/2 | 1/2 | 8451 1550 74 |
| LLA5000-L ATEX ^b | 11000 | 1.6 | 5.2 | 2 | 65.5 | 144.4 | 2.9 | 1.9 | 2 x Lifting height + 0.9 | 40 | 85 | 12.5 | 1/2 | 1/2 | 8451 1550 58 |

^a Without overload protection device.

^b Overload protection device included.

^c Unpainted, corrosion resistant.

Performance figures are at 6.3 bar (91 psi) working pressure.

NOTE: Load chain and control chain must be ordered separately.

Dimensions

| Model | A | | B | | C | | D | |
|---------------------|-----|------|-----|-----|-----|------|----|-----|
| | mm | in | mm | in | mm | in | mm | in |
| LLA250-L ATEX | 377 | 14.8 | 122 | 4.8 | 390 | 15.4 | 29 | 1.1 |
| LLA500-L ATEX | 377 | 14.8 | 122 | 4.8 | 390 | 15.4 | 29 | 1.1 |
| LLA980-L ATEX | 445 | 17.5 | 122 | 4.8 | 390 | 15.4 | 29 | 1.1 |
| LLA1000-L ATEX | 495 | 19.4 | 122 | 4.8 | 390 | 15.4 | 29 | 1.1 |
| LLA2500/3000-L ATEX | 575 | 22.6 | 212 | 8.3 | 546 | 21.5 | 50 | 2.0 |
| LLA5000-L ATEX | 785 | 30.9 | 249 | 9.8 | 546 | 21.5 | 60 | 2.4 |

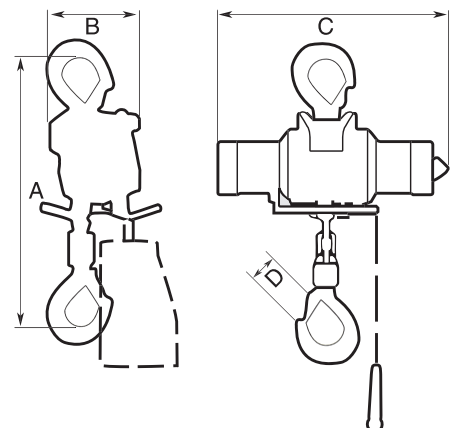

Atlas Copco trolleys are available in 3 sizes, for maximum loads of 1, 3 and 5 tonnes. All models can be offered with air motor drive. Pendant Control are not included with the trolleys (must be ordered separately). The 3 and 5 tonne includes handle for control chain (control chain must be ordered separately). The 1 and 3 tonne trolleys are also available in manual versions.

- Lubrication free



| Model | Max capacity | | Max speed with full load | | Air consumption | | Beam width | | Curve radius min | | Weight | | Ordering No. |
|--------------------------|--------------|------|--------------------------|--------|-----------------|---------|------------|----------|------------------|------|--------|--------------|--------------|
| | lb | | m/min | ft/min | l/s | cfm | mm | in | mm | in | kg | lb | |
| Manual | | | | | | | | | | | | | |
| TLT1000-H-N | 2200 | | - | - | - | - | 50-160 | 2-6.3 | 1250 | 50 | 9.4 | 21 | 8451 1520 06 |
| TLT1000-H-W | 2200 | | - | - | - | - | 161-280 | 6.3-11 | 1250 | 50 | 11 | 24 | 8451 1520 63 |
| TLT3000-H-N | 6600 | | - | - | - | - | 74-180 | 2.9-7.1 | 2200 | 86.6 | 32 | 70 | 8451 1520 55 |
| TLT3000-H-W | 6600 | | - | - | - | - | 181-300 | 7.1-11.8 | 2200 | 86.6 | 34 | 75 | 8451 1520 89 |
| Motor driven | | | | | | | | | | | | | |
| TLT1000-M-N ^a | 2200 | 14 | 45.9 | 4 | 8.5 | 50-160 | 2-6.3 | 1250 | 50 | 11 | 24 | 8451 1520 14 | |
| TLT1000-M-W ^a | 2200 | 14 | 45.9 | 4 | 8.5 | 161-280 | 6.3-11 | 1250 | 50 | 12 | 27 | 8451 1520 71 | |
| TLT3000-M-N ^b | 6600 | 17.8 | 58.4 | 42 | 89 | 74-180 | 2.9-7.1 | 2200 | 86.6 | 48 | 106 | 8451 1520 30 | |
| TLT3000-M-W ^b | 6600 | 17.8 | 58.4 | 42 | 89 | 181-300 | 7.1-11.8 | 2200 | 86.6 | 52 | 114 | 8451 1520 97 | |
| TLT5000-M ^b | 11000 | 16.2 | 53.1 | 42 | 89 | 181-300 | 7.1-11.8 | 2500 | 98.4 | 74 | 163 | 8451 1520 48 | |

^a Pendant control must be ordered separately.

^b Includes handle for control chain. Control chain must be ordered separately.

Performance figures are at 6.3 bar (91 psi) working pressure.

Motor-driven trolleys have 1/2" BSP air connection.

12.5 mm (1/2") hose size is recommended for TLT1000-MN/MW, 20 mm for TLT3000-MN/MW and TLT5000-M.

Dimensions

| Model | A | | B | | C | | D | | E | | F | |
|---------------------|----|-----|----|-----|-----------------|------------------|-----|-----|-----|------|----|-----|
| | mm | in | mm | in | mm | in | mm | in | mm | in | mm | in |
| Manual | | | | | | | | | | | | |
| TLT1000-H-N | 26 | 1.1 | 52 | 2.0 | 212 | 8.3 | - | - | 264 | 10.4 | - | - |
| TLT1000-H-W | 26 | 1.1 | 52 | 2.0 | Beam width + 57 | Beam width + 2.3 | - | - | 264 | 10.4 | - | - |
| TLT3000-H-N | 35 | 1.4 | 78 | 3.1 | 262 | 10.3 | - | - | 384 | 15.2 | - | - |
| TLT3000-H-W | 35 | 1.4 | 78 | 3.1 | Beam width + 89 | Beam width + 3.5 | - | - | 384 | 15.2 | - | - |
| Motor driven | | | | | | | | | | | | |
| TLT1000-M-N | 24 | 1.0 | 52 | 2.0 | 212 | 8.3 | 225 | 8.9 | 264 | 10.4 | - | - |
| TLT1000-M-W | 24 | 1.0 | 52 | 2.0 | Beam width + 57 | Beam width + 2.3 | 225 | 8.9 | 264 | 10.4 | - | - |
| TLT3000-M-N | 37 | 1.5 | 78 | 3.1 | 262 | 10.3 | 148 | 5.9 | 380 | 15.0 | 94 | 3.7 |
| TLT3000-M-W | 37 | 1.5 | 78 | 3.1 | Beam width + 89 | Beam width + 3.5 | 148 | 5.9 | 380 | 15.0 | 94 | 3.7 |
| TLT5000-M | 41 | 1.6 | 93 | 3.7 | Beam width + 97 | Beam width + 3.8 | 166 | 6.6 | 437 | 17.2 | 59 | 2.4 |

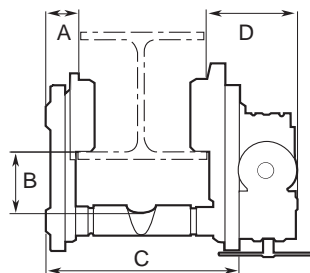

Accessories Included

FOR HOISTS

Wooden handle for pull chain
Hose nipple BSP 1/2"
Suspension hook and load hook

FOR TROLLEYS

TLT3000-MN/MW/5000-M
Wooden handle for pull chain

Optional Accessories

FOR AIR HOISTS

| Designation | LLA250/500/ 980/1000 ATEX Ordering No. | LLA500-L-W ATEX Ordering No. | LLA2500/ 3000/5000 ATEX Ordering No. |
|-----------------------------------|--|---------------------------------|--|
| Load chain, zinc plated, per m | 4310 2293 00 | 4310 2293 00 | 4310 2296 00 |
| Control chain, zinc plated, per m | 4310 0748 00 | 4310 0748 00 | 4310 0748 00 |
| 2 button pendant control | | | |
| Handle and actuators only | 4310 2301 90 | 4310 2301 91 | 4310 2302 90 |
| Hose set per m | 4310 2310 91 | 4310 2310 91 | 4310 2310 91 |
| 4 button pendant control | | | |
| Handle and actuators only | 4310 2303 90 | – | 4310 2304 90 |
| Hose set per m | 4310 2310 94 | – | 4310 2310 93 |
| Twist rod control | | | |
| Complete (1.1-2.0 m) | 4310 0774 91 | 4310 0774 91 | 4310 0774 91 |
| Extension set (1.1-1.9 m) | 4310 0780 91 | 4310 0780 91 | 4310 0780 91 |
| Articulating link | 4310 0876 91 | 4310 0876 91 | 4310 0876 91 |
| Chain collectors | | | |
| PVC for length of chain | | | |
| – 4 m | 4310 0742 04 | 4310 0742 04 | – |
| – 7 m | 4310 0742 07 | 4310 0742 07 | 4310 2291 07 |
| –12 m | 4310 0742 12 | 4310 0742 12 | – |
| –18 m | 4310 0742 18 | 4310 0742 18 | – |
| –25 m | 4310 0742 25 | 4310 0742 25 | – |
| Chain collectors | | | |
| Steel for length of chain | | | |
| –12 m | – | – | 4310 2102 80 |
| –18 m | – | – | 4310 2109 80 |
| Overload protection device | | | |
| LLA250 ATEX | 4310 0812 83 | – | – |
| LLA500 ATEX | 4310 0812 84 | 4310 0812 84 | – |
| LLA980 ATEX | 4310 0812 85 | – | – |
| LLA3000 ATEX | – | – | 4310 0806 90 |
| LLA1000/2500/5000 ATEX | incl as standard | – | incl as standard |
| Safety hooks, zinc plated | 4310 0739 01 | 4310 0739 01 | – |
| Chain stop, zinc plated | 4310 0740 91 | 4310 0740 91 | 4310 2097 91 |

NOTE: For items specified per metre, the required length should be indicated by multiplying the Ordering No. by the required length, ie. to order 12 m of chain for an LLA250 the order should be **12 x 4310 2293 00**.

When ordering load chain, follow the recommendations on chain given in the technical data for LLA hoists.

FOR TROLLEYS

| Designation | TLT1000-M Ordering No. | TLT3000-M Ordering No. | TLT5000-M Ordering No. |
|---------------------------------|---------------------------|---------------------------|---------------------------|
| Zinc plated control chain per m | | 4310 0748 00 | 4310 0748 00 |
| 2 button pendant control | | | |
| Handle and actuator only | 4310 0835 91 | 4310 2301 90 | 4310 2301 90 |
| Hose kit per m | 4310 2310 92 | 4310 2310 91 | 4310 2310 91 |

SERVICE



Contents

| | |
|------------------------------------|-----|
| Introduction..... | 336 |
| Service packages | 337 |
| Service packages for new equipment | 339 |

It pays to let the original manufacturer service your tools

An Atlas Copco service program is designed to cut your production costs. The savings you can expect depend on how your production looks today – line assembly or fixed stations, tool types used, applications, frequency of tool use, work environment and other factors.

An Atlas Copco ToolScan or a ToolScan RCM on your tool population will give you the answers to these questions. By acting on the recommendations provided, many customers have reported savings in production costs of up to 60%.

A properly serviced tool will perform correctly for longer periods, it will also consume less energy and get the job done faster.

Use our Operating Cost Savings Calculator on your tools to identify potential savings.

ARE YOU GETTING THE MOST FROM YOUR AIR TOOLS?

- Would your tools work better with a Preventive Maintenance Program (PM)?
- Are the tools correctly adjusted for the application?
- Have you checked your air line for correct flow, air quality, leakages, etc.?
- Is your air line system correctly dimensioned?
- Are there areas with significant pressure drops?
- Do you know the status and number of tools in your production?
- What is the power efficiency (l/kWs) of your tools?
- Do you use the optimal tool for each application?



WOULD YOU LIKE TO REDUCE THE OPERATING COSTS FOR YOUR ELECTRIC TOOLS?

- Have you calculated the total operating cost of your tools and the impact a Preventive Maintenance Program could have?
- Are you currently performing any preventive maintenance, or just repairs when tools break down?

With our ToolScan RCM process we can optimize a Preventive Maintenance Program for your type of production. This can provide cost savings of up to 60% and, in some cases, even more. Our RCM Operating Cost Savings Calculator helps you to identify your total potential savings.

HOW COULD YOUR PRODUCTION BE OPTIMIZED?

- Is your operation really a zero-fault production?
- Could productivity be improved on your line?
- In new production projects is the focus on quality and efficiency?

Bolted joint issues arise in all types of assembly. While the tooling is often wrongly blamed, in most cases there are other factors affecting the bolted joint. In Production Optimization we take care of these issues, both in existing production and in new projects.

Your ideal Service Partner

At Atlas Copco, we continuously seek ways to improve our customers' operations, as well as our own. With this in mind, we are determined to be the world's most professional supplier of industrial service solutions for fixtured and hand-held power tools. To achieve that we have developed a range of standard service packages that will help our customers to improve their quality and productivity in production.

EFFECTIVE SERVICE PACKAGES

REPAIR

With today's high demands on minimizing downtime for our customers, we focus on specialized workshops that can handle quick repairs and complete overhauls in the most cost-efficient way. To do that we keep a large inventory of spare parts in stock, and we have upgraded with factory fixtures and test equipment to increase our efficiency. With all this, plus certified mechanics dedicated to specific tool models, we've minimized lead times and improved the quality of each repair. After service all tools are rigorously tested to Atlas Copco specifications.

Using the box system:

- Place the broken tool in the box.
- Sign up for direct repair according to the fixed price or a quote.
- The tool is repaired, tested and sent back to you with a full report.

TOOLSCAN™

Our ToolScan™ report informs you of the status of your air tools and air supply at each workstation. The service is carried out by a highly experienced certified technician and covers the following areas:

- AirScan of the air supply at each workstation.
- Status and performance check of the tools.
- Other services can be added.
- A report informing you of the status of your air supply and tools, including recommendations for improvements. You can then, together with your team, decide the next step without a binding agreement.



CALIBRATION

With our network of calibration laboratories we can offer a complete package of calibration services to help you control quality for all assembly tools and measurement equipment in your production.

An efficient way to control quality:

- Traceability and document management.
- Calibration/verification of transducerized tools and controllers.
- Torque adjustment and capability test.
- Verification test for a specific application.
- Accredited and factory calibration of measurement equipment.
- Testing and calibration of click and torque wrenches.
- Other special requests, such as angle calibration, etc.
- We remind you for your next calibration.



PREVENTIVE MAINTENANCE

Like other machines, Atlas Copco industrial power tools need regular maintenance in order to fulfill their full potential in terms of performance and reliability. Different agreements are available, tailored to your needs. We offer maintenance both on-site or off-site, or a combination. With our Operating Cost Calculator, you can calculate the potential savings a preventive maintenance program will provide for your specific operation.

FULL COVERAGE

A fixed budget for all tool maintenance. Our Full Coverage option keeps power tools in top operating condition and provides a fixed budget for all tool maintenance. Other services can be added. To develop the optimum service program for their specific manufacturing operation, customers can take advantage of our unique ToolScan RCM process. For your new tools, take a look at our ToolCover.

Full Coverage includes:

- Repair, including parts.
- Calibration.
- Preventive maintenance program.
- On-site/off-site options.
- Other services can be added.

TOOLSCAN RCM

RCM (Reliability Centered Maintenance) is a proven method of rationalizing and optimizing maintenance costs in manufacturing industries. With ToolScan RCM we balance maintenance against the operational cost of a failure. Based on our extensive tool failure statistics, we analyze your total operating costs, the tool applications and the probability of tool failure. With this information we create the optimum maintenance program for your specific production operation.

OUTSOURCING SOLUTIONS

We have extensive experience of outsourcing solutions and currently have more than 120 Tool Management Centers located inside customer facility. These are examples of the areas we cover:

Focus on your core business:

- Preventive maintenance, repair and calibration of all brands and types of tools.
- Installation and start-up support.
- Service management system, including developing Key Performance Indicators.
- Line and process support.
- Back-up tool/equipment and spare parts management.
- Other customer requests.

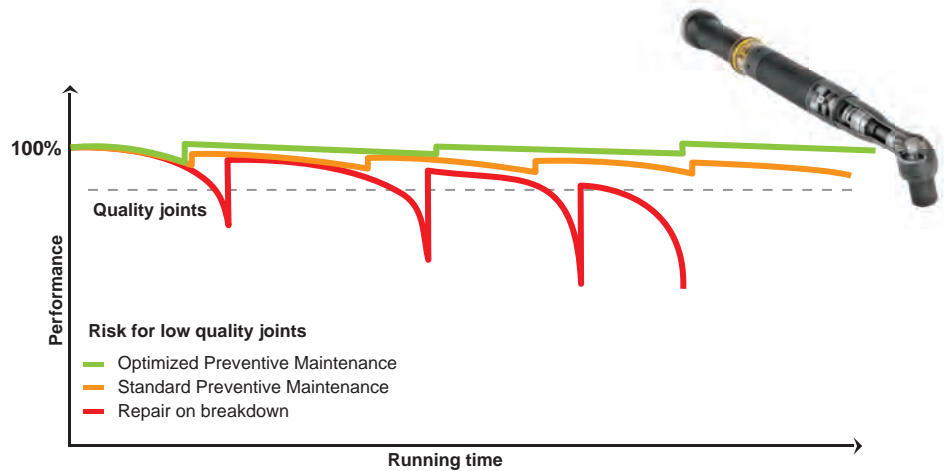

By keeping your assembly tool in the low risk area the chance of failures and torque scatter is minimized.

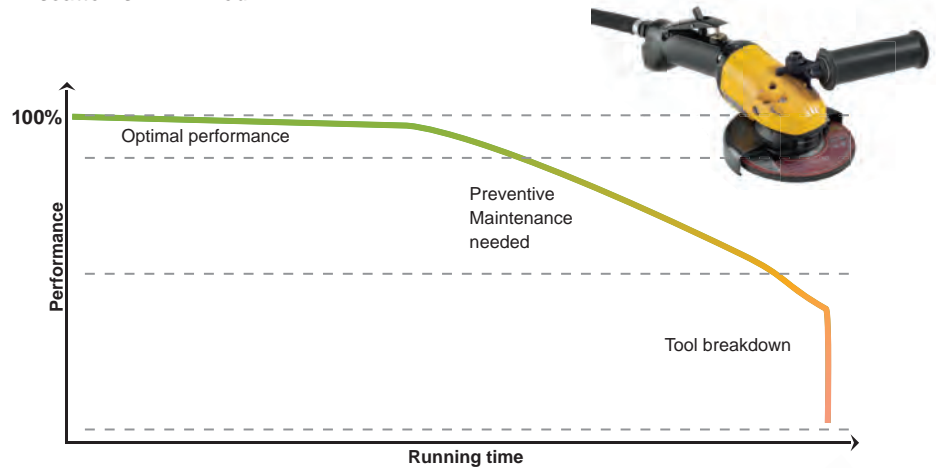

Correct lubrication of all gears is crucial for highly productive industrial tools. The most common cause of oil/grease leakage is worn seals.

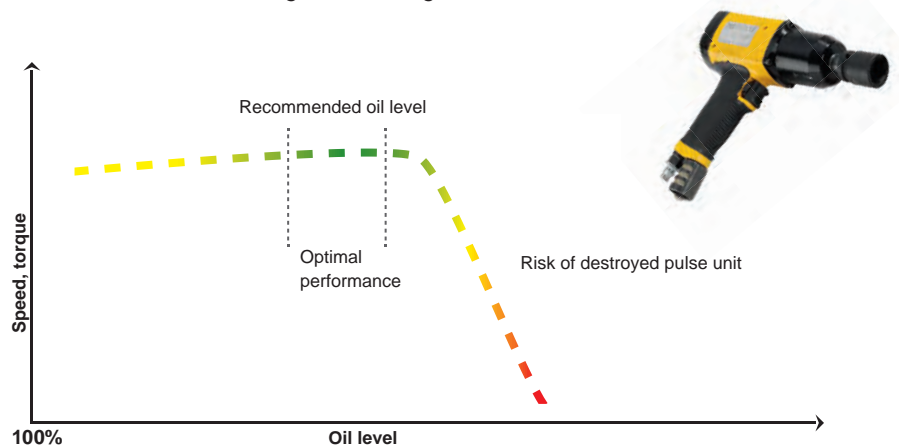

Oil level decrease in small steps during operation and could end up in a destroyed pulse unit. Most of our customer have to replace the tool because of that.

SOME TYPICAL KPI INDICATORS USED:

- Turnaround time for repair.
- MTR (Mean Time To Repair).
- MTBF (Mean Time Between Failures).
- Number of preventive maintenance actions vs. repair/failure development.
- Root cause analysis.
- Top 5 problem applications with actions.
- Availability of equipment.

Service packages for new equipment

Maximize your investment. Investing in new tools to upgrade an existing production line? Or perhaps you're designing, installing and commissioning an entirely new line. In either case Atlas Copco's specialists are there every step of the way to help you focus on quality and efficiency. With your production up and running our service programs will help keep you online with minimum interruptions.

INSTALLATION

Ensure trouble-free operation. A certified Atlas Copco technician ensure the highest quality installation and management of new tools and surrounding equipment. After each installation you receive an installation report that also suggests improvements in your production. With our fixed price installation and startup programs you always know the cost in advance.

PRODUCTION START-UP

Solve issues before going into full production. One of the most critical phases with your new equipment is start-up. Here we have the opportunity to solve issues in a way that will avoid problems during full production. Our certified technicians have long experience of starting up our equipment. With our expertise we make sure you get the best possible start for your full production.

CUSTOMER TRAINING

Helps raise productivity. Having well-trained operators, line engineers and quality people in your operation, means improved tool performance, higher productivity and correct use of your tools and equipment.

Our training also gives your personnel the capability to determine whether production issues and interruptions are the result of problems with the tools or with the parts used in assembly.

We have developed an extensive range of training courses that are supported from our larger Customer Centers throughout the world.



Service Packages for new equipment

PRODUCTION OPTIMIZATION

Zero fault production at the lowest total cost. One of our core competences is production optimization. We help you to improve productivity in your existing assembly, or in your new production project. We ensure that the focus remains on quality and efficiency from concept/R&D through to full production. While bolted joint issues are the common denominator, there are many other factors involved.

IMPROVE PRODUCTIVITY ON YOUR EXISTING LINE

Program optimization: Taking advantage of the functionality of our advanced controllers, our field engineers optimize monitoring and control limits to identify faulty joints.

Friction analysis: When quality issues like broken or elongated bolt are identified, the cause can be frictional changes in the bolted joint. A laboratory analysis can highlight the root cause enabling a solution to be found.

Joint analysis: If the problem is more complex, a full joint analysis might be necessary. Atlas Copco has the laboratory equipment, expertise and software to evaluate the development of clamp load in bolted joints, as well as optimized rundown specifications.

Production optimization: Analysis of the entire workstation from the perspective of the bolted joint is Atlas Copco's unique method of optimizing production. It can help raise product quality and achieve cost-effective production.

FOCUS ON QUALITY AND EFFICIENCY IN NEW PROJECTS

Concept R&D: Actions include – Bolted joint review, clamp load and friction analysis, tool accessibility and rundown specification analysis.

Strategy development: Actions include – Bolted joint analysis, SW simulation, joint classification, tool selection, fastening process and error-proofing development.

Pilot test: Actions include – Bolted joint analysis, implementation of customized fastening processes and sequences, clamp load, frictional and quality validation.

Pre production: Actions include – Bolted joint analysis, evaluating process limits, joint analysis, optimizing sequencing, cycle time, bolt relaxation and product quality.

Full production: Actions include – Bolted joint analysis, determination of Cp/Cpk, quality status, overview of assembly potentials, quality system potentials and ergonomic improvement.



SERVICE PROGRAMS – FULL COVERAGE PROGRAMS AND ON-SITE TECHNICIAN

Depending on the size of your operation, different service programs are available for your new Atlas Copco equipment. Atlas Copco ToolCover programs ensure trouble-free operation for your tools. If you have a new plant or larger new production line, an on-site Atlas Copco technician is a recommended option. We have long experience of handling new tool and installation issues in an efficient way.

TOOLCOVER

- Full coverage option for two or three years.
- Cover both repairs and parts.
- Preventive Maintenance program tailored to your production rate.
- Yearly calibration with protocol.
- Inspection protocol checking critical points on tools/system.
- Off-site / On-site options.

REMOTE SERVICE

Today we can offer remote service as part of our contracts in some markets. Please contact your service representative for more information.



Vibration and Noise Emission Values

The values you will find in this table are the official declared values both for vibration and noise. On December 29, 2009 the Machinery Directive, 2006/42/EC repealed the old directive 98/37/EC. From that date the 3-axes vibration total values are the official values. Our tools are measured according to the relevant part in the ISO 28927 series. For machines where no specific test code exists the ISO 20643 is used.

MEASURING VIBRATIONS

Our declared vibration values are expressed as vibration total value and a vibration total value is the vector sum of the weighted vibration in three directions.

On machines intended to be used with two hands, two positions are measured and the position with the highest value is declared.

MEASURING NOISE

Our declared noise emission information is derived according to the standard EN ISO 15744. The A-weighted emission sound pressure level is measured in a semi-anechoic room at 5 points around the tool. The declared sound pressure level for the tool is the average sound pressure level from the 5 microphones. If the declared sound pressure level exceeds 80 dB(A), the A-weighted sound power level is declared in addition to the sound pressure level.

Because each tool can be used in many different applications, it is impossible to predict what the process sound pressure level will be, therefore EN ISO 15744 specifies that most types of tools are run under no load conditions with the supplied accessories mounted.

SUITABLE FOR COMPARISON PURPOSES ONLY

The declared values given in this table were obtained by laboratory type testing in accordance with the stated standards and are suitable for comparison with the declared values of other tools tested in accordance with the same standards.

These declared values are not adequate for use in risk assessments and values measured in individual work places may be higher. The actual exposure values and risk of harm experienced by an individual user are unique and depend upon the way the user works, the workpiece and the workstation design, as well as upon the exposure time and the physical condition of the user.



Atlas Copco has a well equipped laboratory for measuring tool noise and vibration emissions. It contains advanced vibration measurement tools, a state-of-the-art acoustics laboratory and dedicated computer software for analysing measurement and test results.

Atlas Copco Industrial Technique AB, cannot be held liable for the consequences of using the declared values, instead of values reflecting the actual exposure, in an individual risk assessment in a work place situation over which we have no control.

MANAGING EXPOSURE TO NOISE AND VIBRATION

Power Tools may cause hand-arm vibration syndrome if the use is not adequately managed. An EU guide to managing hand-arm vibration can be found by accessing <http://www.pneurop.eu/index.php> and selecting 'Tools' then 'Legislation'.

We recommend a programme of health surveillance to detect early symptoms which may relate to noise or vibration exposure, so that management procedures can be modified to help prevent future impairment.

Vibration and Noise Emission Values

Assembly tools

| Model | Vibration total value (3 axes value) according to ISO 28927-2 Valid from 2010 | | Sound pressure levels and sound power levels ^a according to ISO 15744 | | Model | Vibration total value (3 axes value) according to ISO 28927-2 Valid from 2010 | | Sound pressure levels and sound power levels ^a according to ISO 15744 | |
|--------------------------------|---|------------------------------|--|-------------------|-------------------------------------|---|------------------------------|--|-------------------|
| | Value 3-axes m/s ² | Uncertainty m/s ² | Sound pressure dB(A) | Sound power dB(A) | | Value 3-axes m/s ² | Uncertainty m/s ² | Sound pressure dB(A) | Sound power dB(A) |
| Pneumatic screwdrivers | | | | | Impact Wrenches | | | | |
| Pistol grip | | | | | Pistol grip | | | | |
| Shut-off | | | | | Non shut-off | | | | |
| LUM22 HR | <2.5 | - | 78 | - | LMS08 HR | <2.5 | - | 85 | 96 |
| LUM32 HR | <2.5 | - | 77 | - | LMS18 HR | 5.3 | 1.5 | 90 | 101 |
| LUM12 HRX | <2.5 | - | 74 | - | LMS28 HR | 5.2 | 1.3 | 92 | 103 |
| LUM22 HRX | <2.5 | - | 78 | - | LMS38 HR | 3.5 | 1.5 | 88 | 99 |
| LUM10 HRX | <2.5 | - | 72 | - | LMS48 HR | 5.0 | 1.4 | 89 | 100 |
| LUM12 HRF | <2.5 | - | <70 | - | LMS58 HR | 5.5 | 1.6 | 92 | 103 |
| Straight | | | | | Straight | | | | |
| Shut-off | | | | | Non shut-off | | | | |
| LUM02 PR | <2.5 | - | 71 | - | LMS08 SR | 5.6 | 2.4 | 85 | 96 |
| LUM10 PR | <2.5 | - | <70 | - | LMS68 GIR/GOR | 8.1 | 2.8 | 98 | 109 |
| LUM12 PR | <2.5 | - | 75 | - | LMS88 GIR/GOR | 4.8 | 2.0 | 100 | 111 |
| LUM22 PR | <2.5 | - | 75 | - | | | | | |
| LUM12 SR | <2.5 | - | 75 | - | | | | | |
| LUM22 SR | <2.5 | - | 78 | - | | | | | |
| Angle | | | | | Hydraulic impulse nutrunners | | | | |
| Shut-off | | | | | Pistol grip | | | | |
| LTV009 | <2.5 | - | 75 | - | Shut-off | | | | |
| LTV18 | <2.5 | - | 71 | - | EP3PTX5 HR42 | <2.5 | - | 76 | - |
| Pistol grip | | | | | EP4PTX9 HR42 | <2.5 | - | <70 | - |
| Direct drive | | | | | EP4PTX9 HR10 | <2.5 | - | <70 | - |
| LUD12 HRX | <2.5 | - | 74 | - | EP5PTX17 HR42 | <2.5 | - | 74 | - |
| LUD22 HR | <2.5 | - | 76 | - | EP5PTX19 HR10 | <2.5 | - | 73 | - |
| LUF34 HRD | <2.5 | - | 79 | - | EP6PTX28 HR42 | 3.0 | 1.0 | 77 | - |
| COMBI22 | <2.5 | - | 76 | - | EP6PTX32 HR10 | <2.5 | - | 75 | - |
| COMBI34 | <2.5 | - | 79 | - | EP7PTX55 HR10 | 4.2 | 0.8 | 79 | - |
| Slip clutch^b | | | | | EP8PTX70 HR10 | 3.5 | 1.0 | 80 | - |
| Pistol grip | | | | | EP9PTX80 HR13 | 5.6 | 0.8 | 82 | 93 |
| TWIST12 HRF | <2.5 | - | 80 | - | EP11PTX120 HR13 | 5.4 | 1.2 | 83 | 94 |
| TWIST12 HRX | <2.5 | - | 80 | - | EP13PTX150 HR13 | 4.7 | 0.7 | 85 | 96 |
| TWIST22 HR | <2.5 | - | 86 | 97 | EP15PTX250 HR20 | 6.5 | 0.4 | 88 | 99 |
| TWIST22 HRX | <2.5 | - | 86 | 97 | EP19PTX450 HR20 | 8.2 | 1.0 | 88 | 99 |
| TWIST HRF | <2.5 | - | 80 | - | EP5PTS12 HR42 | 4.3 | 0.7 | 75 | - |
| LUF34 HR | <2.5 | - | 81 | 92 | EP5PTS14 HR10 | 2.8 | 0.8 | 73 | - |
| Straight | | | | | EP6PTS20 HR42 | 3.4 | 0.5 | 76 | - |
| TWIST12 SR3 | <2.5 | - | 85 | 96 | EP6PTS22 HR10 | 2.9 | 0.7 | 77 | - |
| TWIST12 SR4 | <2.5 | - | 85 | 96 | EP7PTS30 HR42 | 5.9 | 0.9 | 78 | - |
| TWIST22 PR | <2.5 | - | 86 | 97 | EP7PTS35 HR10 | 4.3 | 0.8 | 76 | - |
| TWIST22 SR6 | <2.5 | - | 86 | 97 | EP8PTS40 HR42 | 5.7 | 0.7 | 79 | - |
| TWIST22 SR10 | <2.5 | - | 86 | 97 | EP8PTS55 HR10 | 4.6 | 1.5 | 76 | - |
| Angle | | | | | EP10PTS90 HR13 | 4.8 | 0.9 | 80 | - |
| TWIST VR07 | <2.5 | - | 81 | 92 | EP12PTS150 HR13 | 4.7 | 0.6 | 82 | 93 |
| TWIST VR13 | <2.5 | - | 82 | 93 | EP14PTS250 HR20 | 6.3 | 1 | 85 | 96 |
| | | | | | EP18PTS410 HR20 | 7.1 | 0.8 | 87 | 98 |
| | | | | | EP7PTS35 HRF10 | 4.3 | 0.8 | 76 | - |
| | | | | | EP8PTS55 HRF10 | 4.6 | 1.5 | 76 | - |
| | | | | | EP10PTS90 HRF13 | 4.8 | 0.9 | 80 | - |

^a The uncertainty in the sound levels is 3 dB(A).

^b 1-axis value measured with clutch slipping.

Continued...

Vibration and Noise Emission Values

Assembly tools

| Model | Vibration total value (3 axes value) according to ISO 28927-2 Valid from 2010 | | Sound pressure levels and sound power levels ^a according to ISO 15744 | | Model | Vibration total value (3 axes value) according to ISO 28927-2 Valid from 2010 | | Sound pressure levels and sound power levels ^a according to ISO 15744 | |
|--------------------------------------|---|------------------------------|--|-------------------|-----------------------------|---|------------------------------|--|-------------------|
| | Value 3-axes m/s ² | Uncertainty m/s ² | Sound pressure dB(A) | Sound power dB(A) | | Value 3-axes m/s ² | Uncertainty m/s ² | Sound pressure dB(A) | Sound power dB(A) |
| Hydraulic impulse nutrunners | | | | | Pneumatic nutrunners | | | | |
| Pistol grip | | | | | Angle | | | | |
| Non shut-off | | | | | LTV29-2 R | | | | |
| EP5XS HR42 | <2.5 | - | 78 | - | LTV39-2 R | | | | |
| EP6XS HR42 | 3.0 | 0.5 | 81 | 92 | LTV28 R | | | | |
| EP6XS HR10 | <2.5 | - | 79 | - | LTV38 R | | | | |
| EP6PS HR42 | 3.7 | 0.5 | 81 | 92 | LTV48 R | | | | |
| EP6PS HR10 | 3.1 | 0.7 | 79 | - | LTV69 R | | | | |
| EP8PS HR10 | 4.1 | 1.2 | 82 | 93 | LTV69 N | | | | |
| EP7XS HR42 | 2.7 | 0.7 | 80 | - | LMV28 R | | | | |
| EP7XS HR10 | 2.8 | 1.0 | 79 | - | LMV28 N | | | | |
| EP8XS HRX42 | 2.8 | 0.6 | 78 | - | LMK22 | | | | |
| EP8XS HRX10 | 3.0 | 0.7 | 82 | 93 | LMK33 | | | | |
| EP10XS HR13 | 4.6 | 0.8 | 83 | 94 | Straight | | | | |
| EP12XS HR13 | 6.0 | 1.1 | 85 | 96 | LTD28 N | | | | |
| EP14XS HR13 | 4.0 | 1.4 | 85 | 96 | LTD38 N | | | | |
| EP16XS HR20 | 6.7 | 0.9 | 86 | 97 | LTD28 R | | | | |
| EP20XS HR20 | 6.8 | 1.4 | 87 | 98 | LTD38 R | | | | |
| Hydraulic impulse nutrunners | | | | | LTD48 R | | | | |
| Straight | | | | | LTD61 H | | | | |
| Shut-off | | | | | LMD61 H | | | | |
| EP3PTX5 SR42 | 5.7 | 1.2 | 76 | - | Pistol grip | | | | |
| EP4PTX9 SR42 | 7.1 | 1.6 | 77 | - | RTP1300 | | | | |
| EP4PTX9 SR10 | 4.0 | 1.4 | 77 | - | RTP4100 | | | | |
| EP5PTX14 SR42 | 6.5 | 2.1 | 78 | - | LTP61 PH | | | | |
| EP5PTX15 SR10 | 4.6 | 0.8 | 78 | - | LTP61 H | | | | |
| EP6PTX18 SR42 | 8.4 | 1.2 | 81 | 92 | LTP61 HR | | | | |
| EP6PTX19 SR10 | 6.2 | 1.4 | 81 | 92 | LMP61 H | | | | |
| EP7PTX28 SR42 | 11.5 | 2.4 | 78 | - | LMP61 HR | | | | |
| EP7PTX31 SR10 | 7.8 | 1.8 | 79 | - | LMP24 H | | | | |
| EP8PTX38 SR42 | 11.5 | 5.5 | 80 | - | LMP24 HR | | | | |
| EP8PTX45 SR10 | 7.0 | 1.2 | 81 | 92 | Open end | | | | |
| EP25PTX GR25 | 9.4 | 2.6 | 86 | 97 | LTO28 R | | | | |
| Non shut-off | | | | | LTO38 R | | | | |
| EP6XS SR42 | 5.1 | 1.7 | 80 | - | Crowfoot | | | | |
| EP6XS SR10 | 6.0 | 2.2 | 82 | 93 | LTC009 R | | | | |
| EP7XS SR42 | 6.4 | 1.4 | 79 | - | LTC28 R | | | | |
| EP7XS SR10 | 6.7 | 1.5 | 78 | - | LTC29-2 R | | | | |
| EP8XS SR42 | 6.9 | 0.8 | 81 | 92 | LTC38 R | | | | |
| EP8XS SR10 | 9.5 | 2.2 | 81 | 92 | LTC39-2 R | | | | |
| Monitoring impulse nutrunners | | | | | LTC48 R | | | | |
| Pistol grip | | | | | | | | | |
| EPP6C40 HR | <2.5 | - | 78 | - | | | | | |
| EPP8C55 HR | 3.4 | 0.8 | 81 | 92 | | | | | |
| EPP10C90 HR | 3.3 | 0.9 | 83 | 94 | | | | | |
| EPP11C110 HR | 3.5 | 0.9 | 82 | 93 | | | | | |
| EPP13C150 HR | 3.8 | 0.9 | 87 | 98 | | | | | |
| EPP15C250 HR | 4.9 | 1.5 | 88 | 99 | | | | | |
| EPP19C400 HR | 5.6 | 1.0 | 86 | 97 | | | | | |

^a The uncertainty in the sound levels is 3 dB(A).

Vibration and Noise Emission Values

Material removal tools

| Model | Vibration total value (3 axes value) according to ISO 28927-8 Valid from 2010 | | Sound pressure levels and sound power levels ^a according to ISO 15744 | | Model | Vibration total value (3 axes value) according to ISO 28927-5 Valid from 2010 | | Sound pressure levels and sound power levels ^a according to ISO 15744 | |
|-------------------------|---|------------------------------|--|-------------------|------------------------------|---|------------------------------|--|-------------------|
| | Value 3-axes m/s ² | Uncertainty m/s ² | Sound pressure dB(A) | Sound power dB(A) | | Value 3-axes m/s ² | Uncertainty m/s ² | Sound pressure dB(A) | Sound power dB(A) |
| Grinders | | | | | Drills | | | | |
| Circular cutters | | | | | Pistol grip | | | | |
| LCS10 | 2.6 | 0.9 | 92 | 103 | LBB16 EP | <2.5 | - | 80 | - |
| LCS38 S150-D | <2.5 | - | 86 | 97 | LBB16 EPX | <2.5 | - | 82 | 93 |
| | | | | | LBB26 EPX | <2.5 | - | 82 | 93 |
| | | | | | LBB36 | <2.5 | - | 83 | 94 |
| | | | | | LBB37 | <2.5 | - | 86 | 97 |
| | | | | | LBB45 H017 | <2.5 | - | 88 | 99 |
| | | | | | LBB45 H006 | 3.7 | 1.6 | 88 | 99 |
| | | | | | LBB45 H004 | <2.5 | - | 88 | 99 |
| | | | | | Straight | | | | |
| | | | | | LBB16 S260 | <2.5 | - | 75 | - |
| | | | | | LBB16 S064 | <2.5 | - | 75 | - |
| | | | | | LBB16 S045 | <2.5 | - | 75 | - |
| | | | | | LBB16 S038 | <2.5 | - | 75 | - |
| | | | | | LBB16 S029 | <2.5 | - | 75 | - |
| | | | | | LBB16 S022 | <2.5 | - | 73 | - |
| | | | | | LBB16 S012 | <2.5 | - | 75 | - |
| | | | | | Angle | | | | |
| | | | | | LBV16M 005 | <2.5 | - | 75 | - |
| | | | | | LBV16M 010 | <2.5 | - | 75 | - |
| | | | | | LBV16M 018 | <2.5 | - | 75 | - |
| | | | | | LBV16M 032 | <2.5 | - | 75 | - |
| | | | | | LBV16M 045 | <2.5 | - | 75 | - |
| | | | | | LBV16M 055 | <2.5 | - | 75 | - |
| | | | | | LBV11 30° | <2.5 | - | 72 | - |
| | | | | | LBV16 30° | 2.7 | 0.9 | 75 | - |
| | | | | | LBV36 30° | <2.5 | - | 81 | 92 |
| | | | | | LBV16 45° | <2.5 | - | 75 | - |
| | | | | | LBV11 90° | <2.5 | - | 72 | - |
| | | | | | LBV16 90° | <2.5 | - | 75 | - |
| | | | | | LBV36 90° | <2.5 | - | 81 | 92 |
| | | | | | LBV16 Z | <2.5 | - | 75 | - |
| | | | | | LBV16 90° Large | <2.5 | - | 75 | - |
| | | | | | LBV36 90° Large | <2.5 | - | 81 | 92 |
| | | | | | LBV37 90° Heavy duty | <2.5 | - | 85 | 96 |
| | | | | | LBV16 018-11 Key chuck model | <2.5 | - | 75 | - |
| | | | | | LBV34 S Key chuck model | <2.5 | - | 89 | 100 |
| | | | | | Micro stop drills | | | | |
| | | | | | LBS36 | <2.5 | - | 86 | 97 |
| | | | | | Positive Feed drills | | | | |
| | | | | | PFD1500RA | b | - | 84 | 95 |
| | | | | | | | | | |
| Model | Vibration total value (3 axes value) according to ISO 20643 Valid from 2010 | | Sound pressure levels and sound power levels ^a according to ISO 15744 | | Model | Vibration total value (3 axes value) according to ISO 20643 Valid from 2010 | | Sound pressure levels and sound power levels ^a according to ISO 15744 | |
| | Value 3-axes m/s ² | Uncertainty m/s ² | Sound pressure dB(A) | Sound power dB(A) | | Value 3-axes m/s ² | Uncertainty m/s ² | Sound pressure dB(A) | Sound power dB(A) |
| Drills | | | | | Drills | | | | |
| Tappers | | | | | Tappers | | | | |
| LGB34 H | <2.5 | - | 77 | - | LGB34 H | <2.5 | - | 77 | - |
| LGB34 S | <2.5 | - | 88 | 99 | LGB34 S | <2.5 | - | 88 | 99 |
| LGB36 H | <2.5 | - | 82 | 93 | LGB36 H | <2.5 | - | 82 | 93 |

^a The uncertainty in the sound levels is 3 dB(A).

^b Tools for fixtured applications have no vibration values.

The tool key below explains the significance of the letters/numbers forming the name of the tool model.

Impact wrenches

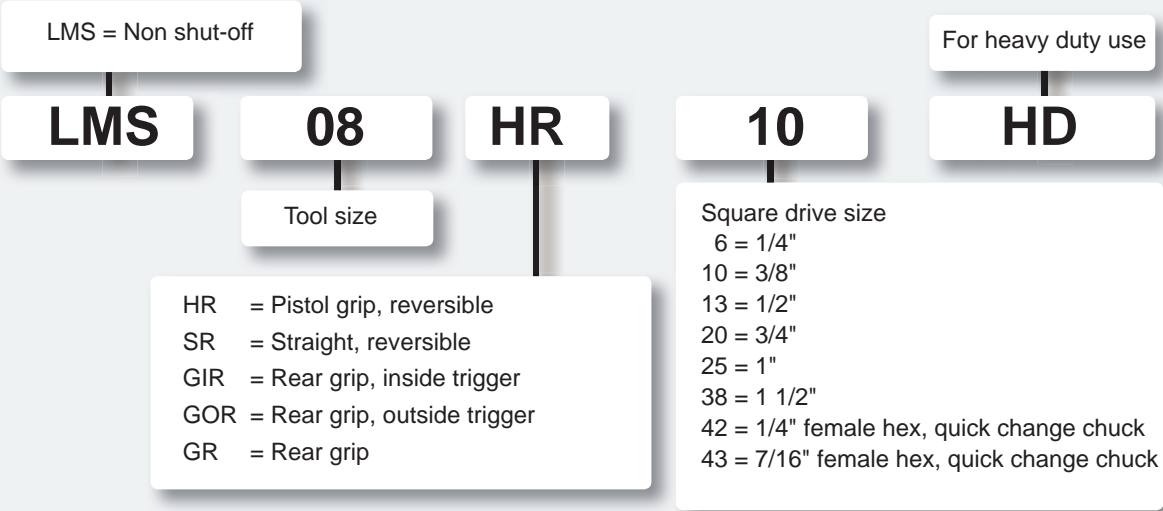

Hydraulic impulse nutrunners

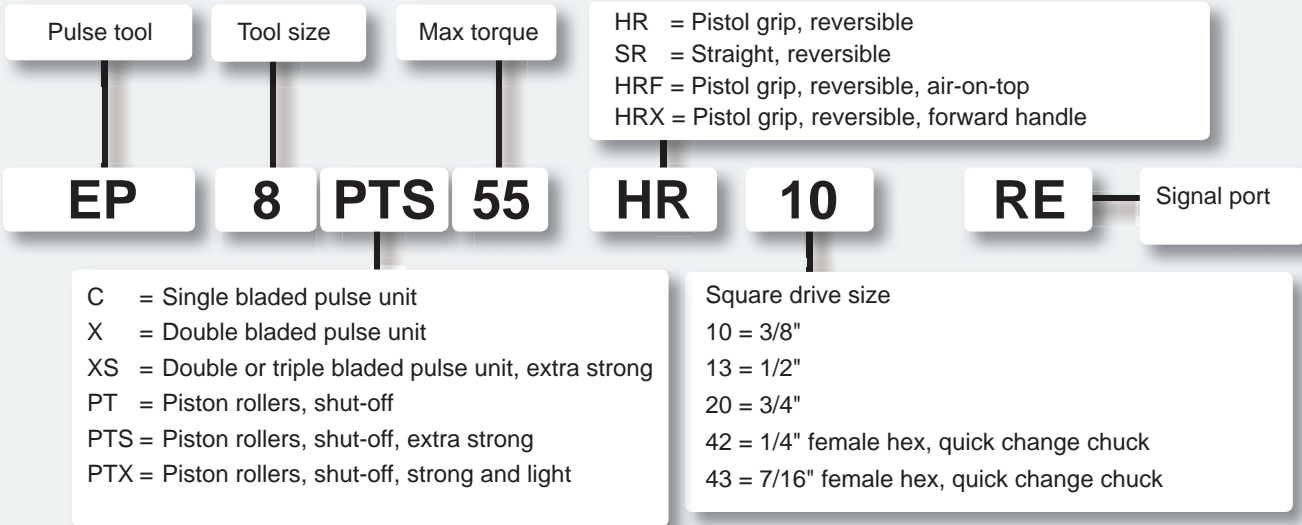

Monitoring impulse nutrunners

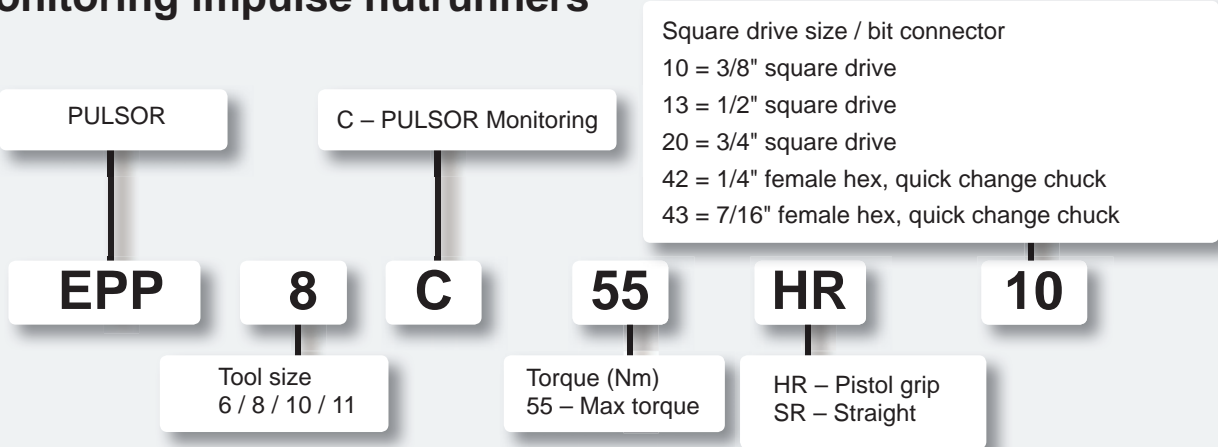

Pneumatic screwdrivers

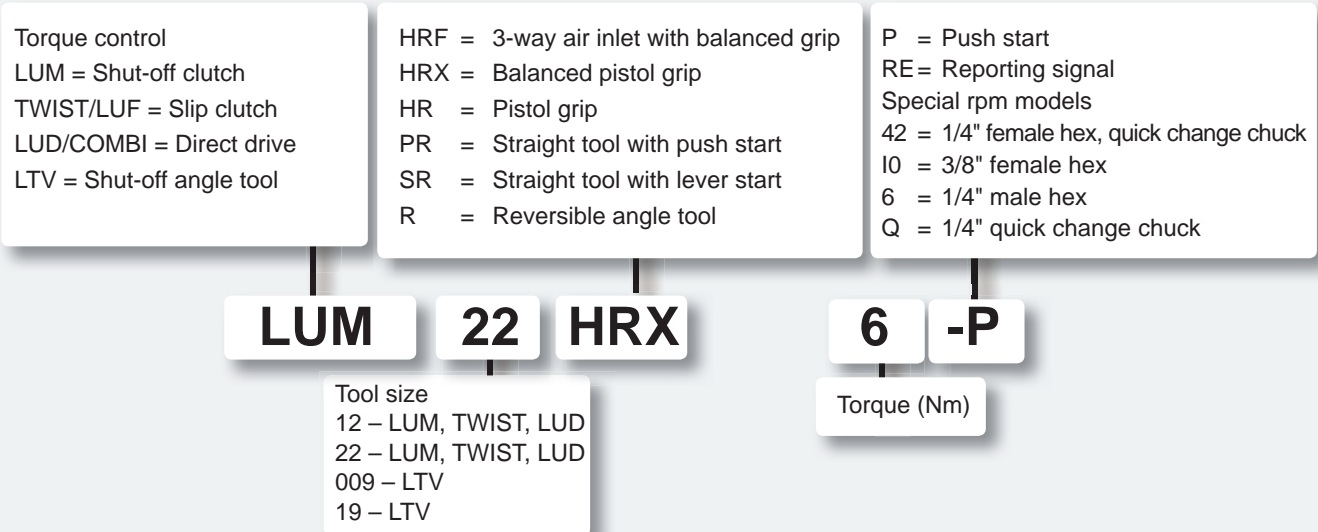

Pneumatic nutrunners

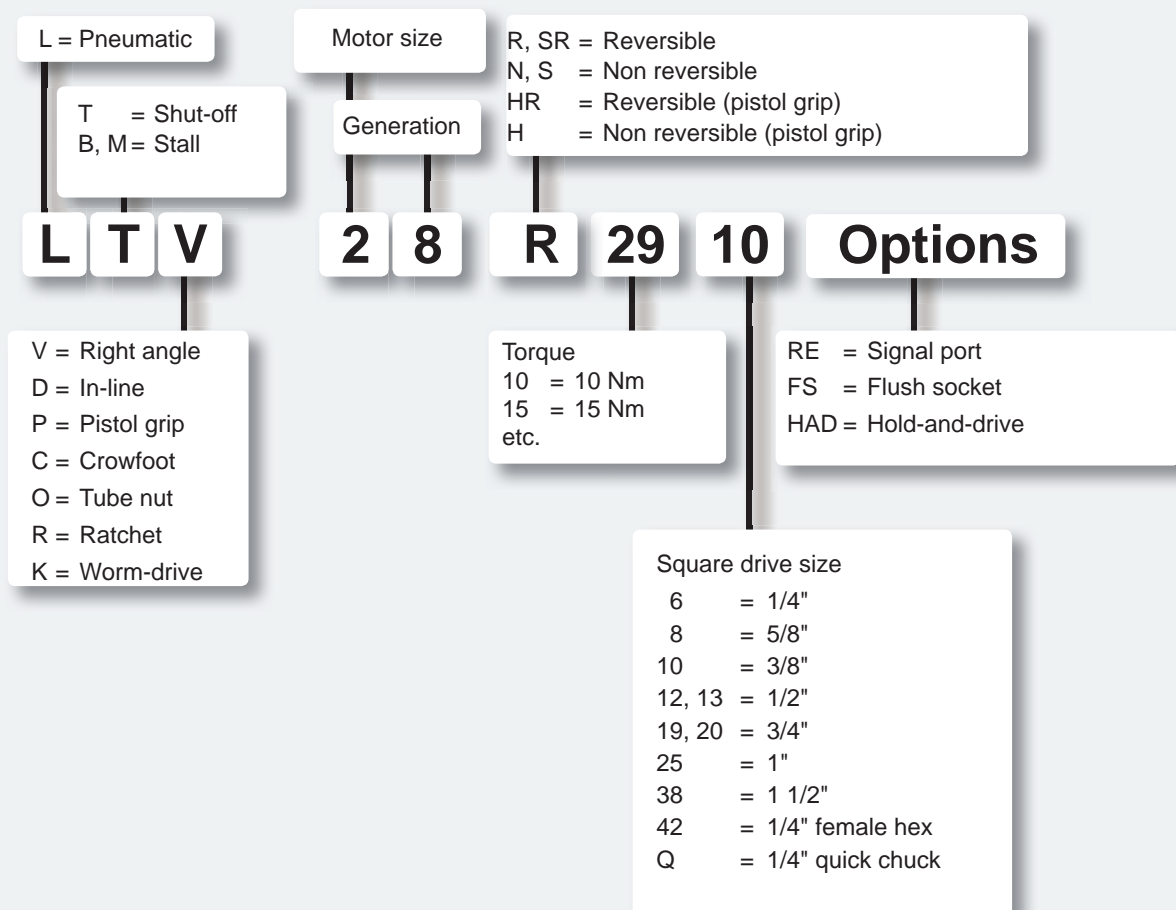

The tool key below explains the significance of the letters/numbers forming the name of the tool model.

Battery screwdriver – BCP

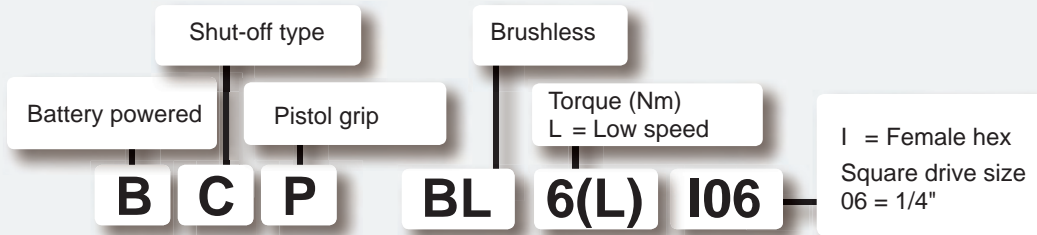

Electric screwdriver – EBL



Electric screwdriver – MicroTorque

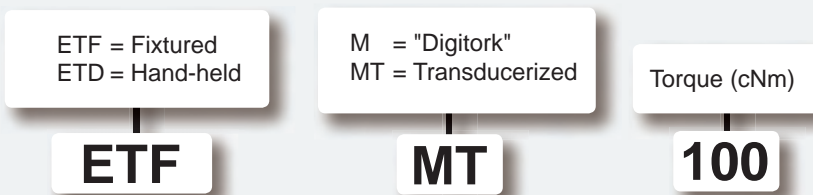

Electric screwdriver – Tensor DL

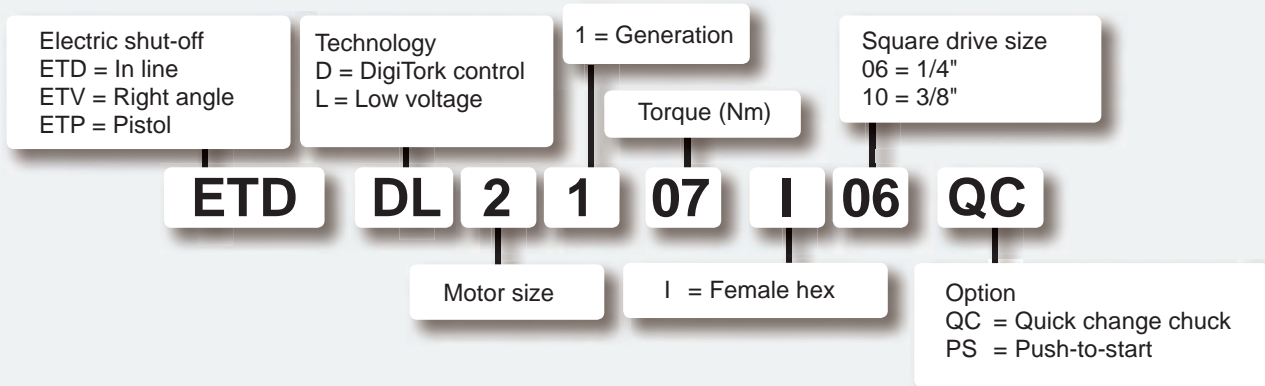

Electric nutrunner – Tensor DS

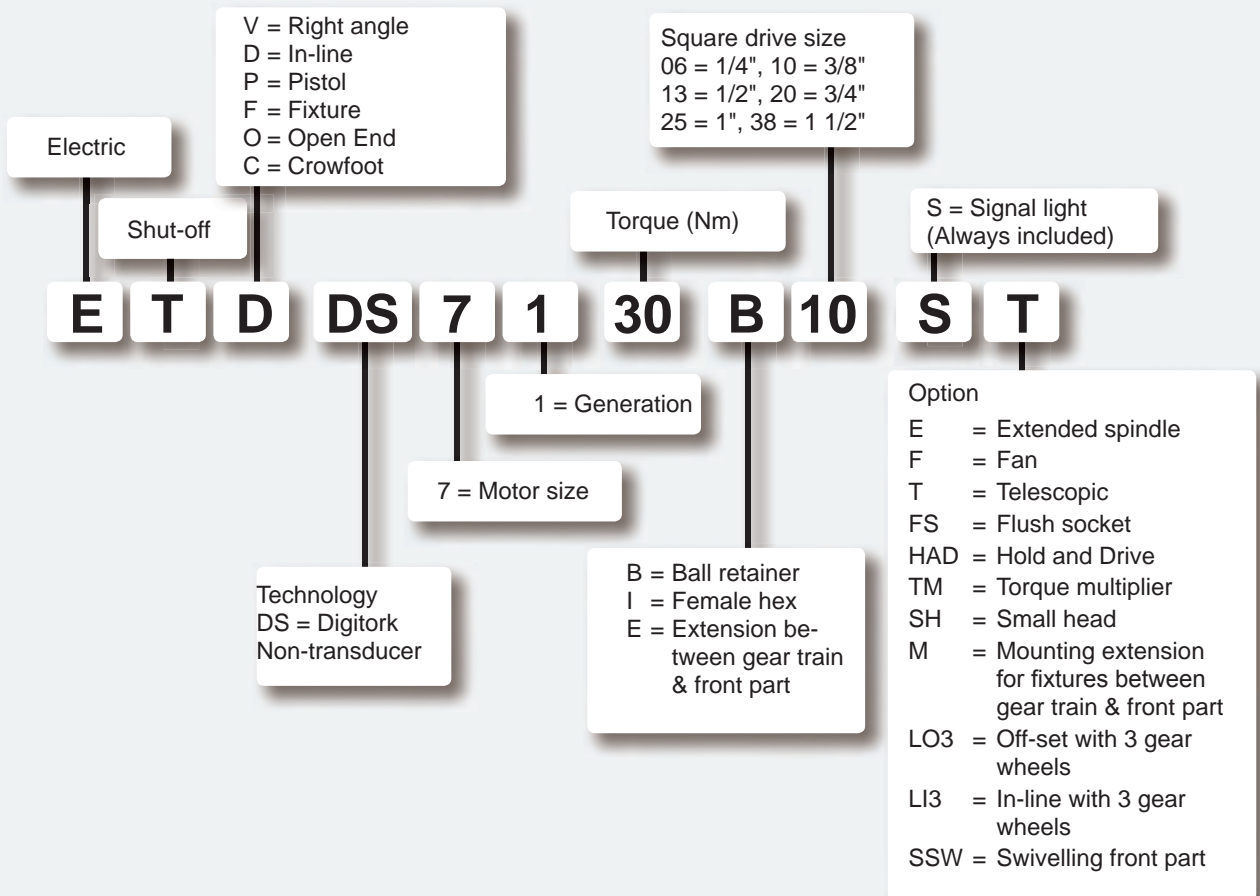

Electric nutrunner – Tensor ST/SL

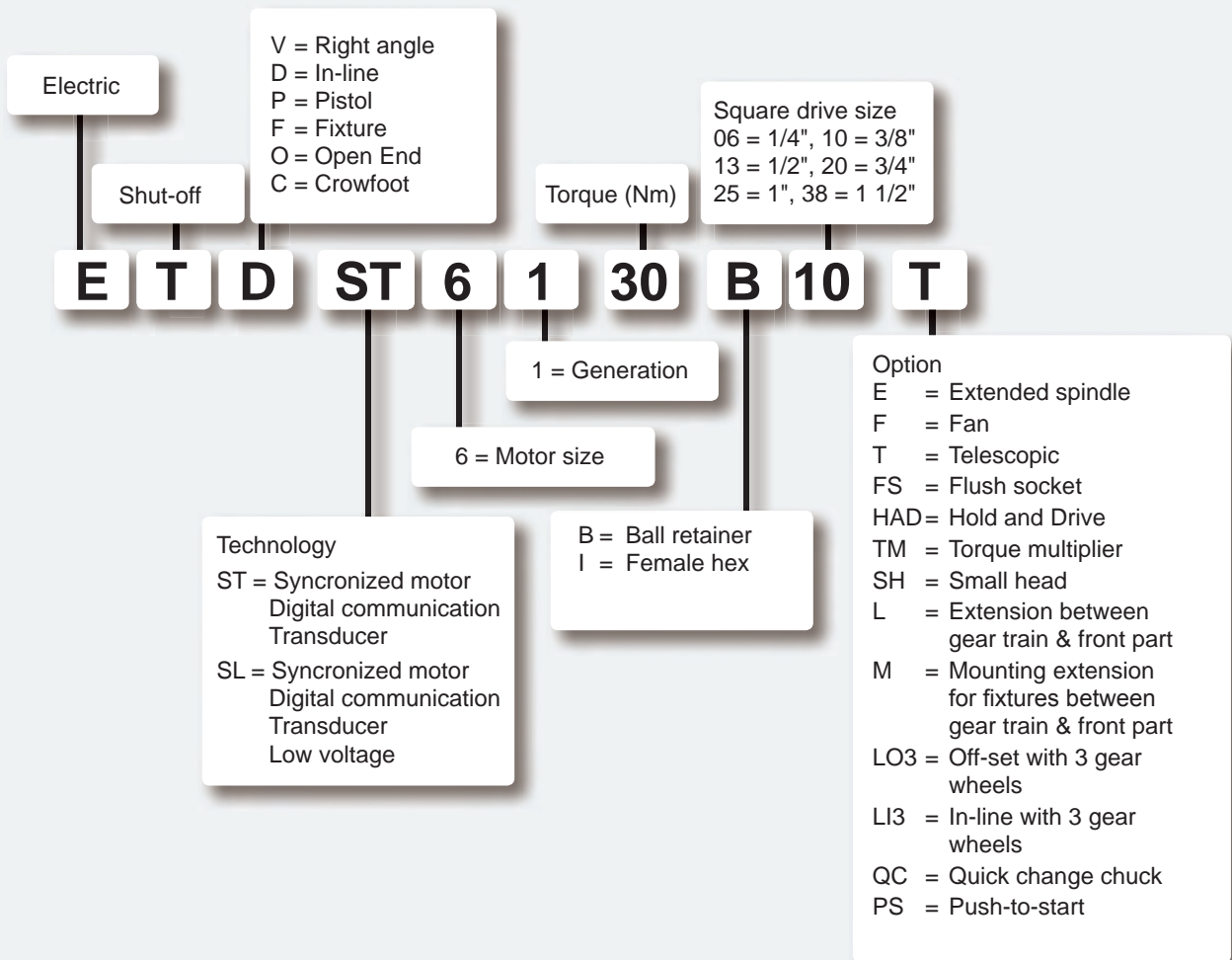

Power Focus

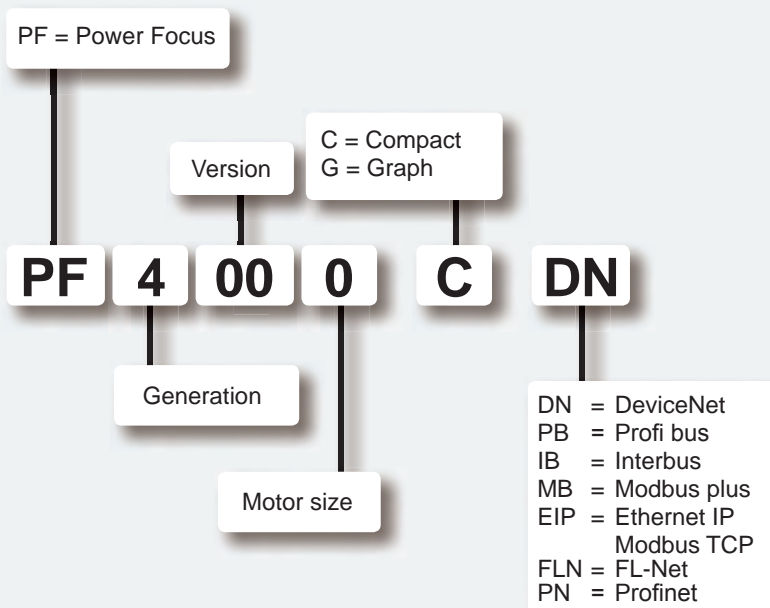

Fixtured nutrunner – QST

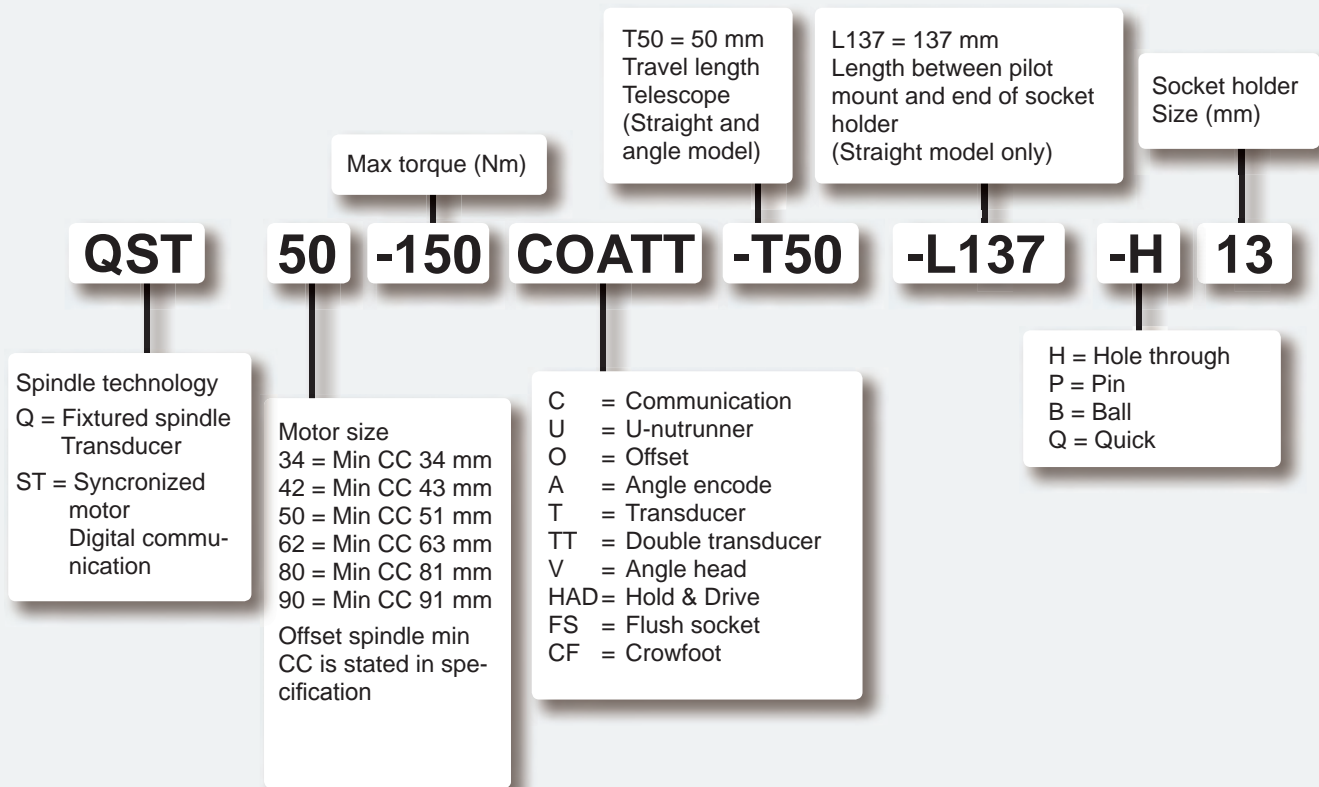

Power MACS 4000

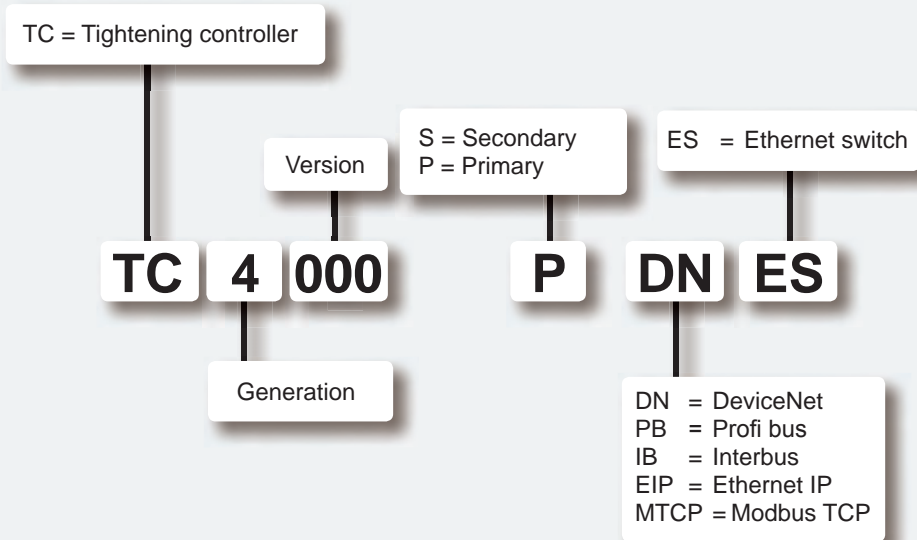

Tool Designations

| | |
|---|---|
| BAL – Ball valve | LLA – Air hoist |
| BCP BL – Battery screwdriver, pistol grip, clutch type | LLT – Trolley |
| BCV – Battery nutrunner, angle model, clutch type | LMD – Pneumatic nutrunner, stall type, straight model |
| BLOCK – Blow protector | LMK – Pneumatic nutrunner, stall type, worm drive |
| CABLAIR – CABLAIR hose | LMP – Pneumatic nutrunner, stall type, pistol grip |
| CLAW – Claw coupling | LMS – Impact wrenches, non shut-off type |
| COL – Colibri balancer | LMV – Pneumatic nutrunner, stall type, angle model |
| COMBI – Pneumatic screwdriver, direct drive | LSF – Die grinder |
| COMBI – Pistol grip drill | LSK – Routers |
| DIM – Air preparation unit, lubricator | LSO – Orbital sander |
| EBL – Electric screwdriver, brushless clutch type | LSR – Straight grinder |
| EP C/X/XS – Hydraulic impulse nutrunner, non shut-off, ERGOPULSE | LST – Random orbital sander |
| EP PT/PTS/PTX – Hydraulic impulse nutrunner, shut-off, ERGOPULSE | LSV – Angle grinder and sander |
| EPP – Monitoring impulse nutrunner, PULSOR C | LTC – Pneumatic nutrunner, shut-off type, crowfoot |
| ErgoNIP – Nipple | LTD – Pneumatic nutrunner, shut-off type, straight model |
| ErgoQIC – Quick coupling | LTO – Pneumatic nutrunner, shut-off type, tube nut |
| ETC DS – Electric nutrunner, shut-off type, crowfoot, TENSOR DS | LTP – Pneumatic nutrunner, shut-off type, pistol grip |
| ETC ST – Electric nutrunner, shut-off type, crowfoot, TENSOR ST | LTV – Pneumatic nutrunner/screwdriver, shut-off angle model |
| ETC STB – Battery nutrunner, crowfoot, TENSOR STB | LUD – Pneumatic screwdriver, direct drive |
| ETD DL – Electric screwdriver, shut-off type, straight model, TENSOR DL | LUF – Pneumatic screwdriver, slip-clutch |
| ETD DS – Electric nutrunner, shut-off type, straight model, TENSOR DS | LUM – Pneumatic screwdriver, shut-off clutch |
| ETD ES – Electric nutrunner, shut-off type, straight model, TENSOR ES | LZB – Small vane air motor |
| ETD M – Electric screwdriver, hand-held "Digitork", MicroTorque | LZL – Vane air motor |
| ETD SL – Electric screwdriver, straight model, TENSOR SL | MRTT-B – Screwdriver for low torque applications |
| ETD ST – Electric nutrunner, shut-off type, straight model, TENSOR ST | MT TH – Torque In/Line rotary transducer |
| ETD STR – Electric screwdriver, straight model, TENSOR STR | MT TR – Torque & Angle In/Line rotary transducer |
| ETF DL – Electric screwdriver, shut-off type, fixture, TENSOR DL | MT TRA – Stationary torque transducer |
| ETF M – Electric screwdriver, fixtured "Digitork", MicroTorque | MT TS – Manual screwdriver torque transducer |
| ETF MT – Electric screwdriver, fixtured transducerized, MicroTorque | MultiFlex – Swivel connectors |
| ETF SL – Electric screwdriver, shut-off type, fixture, TENSOR SL | NIP – Nipple |
| ETO DS – Electric nutrunner, shut-off type, open end, TENSOR DS | Optimizer – Air tool oil |
| ETO ST – Electric nutrunner, shut-off type, open end, TENSOR ST | PFD – Power feed drills |
| ETO STB – Battery nutrunner, tube nut, TENSOR STB | POLUR – Polyurethane hose |
| ETP DL – Electric screwdriver, shut-off type, pistol grip, TENSOR DL | PVC – PVC hose |
| ETP DS – Electric nutrunner, shut-off type, pistol grip, TENSOR DS | QIC – Quick coupling |
| ETP SB – Battery nutrunner, pistol grip TENSOR SB | QRTT – Transducer for spindle and fixtured tool calibration |
| ETP SL – Electric screwdriver, shut-off type, pistol grip, TENSOR SL | QST – Fixtured electric nutrunner, shut-off type |
| ETP STB – Battery nutrunner, pistol grip TENSOR STB | RAB – Screw-feed drill |
| ETP ST – Electric nutrunner, shut-off type, pistol grip, TENSOR ST | RBB – Bucking bar, vibration damped |
| ETP STR – Electric screwdriver, pistol grip, TENSOR STR | REG – Air preparation unit, regulator |
| ETV DL – Electric screwdriver, shut-off type, angle model, TENSOR DL | RIL – Balancer |
| ETV DS – Electric nutrunner, shut-off type, angle model, TENSOR DS | RRC – Chipping hammer, conventional type |
| ETD ES – Electric nutrunner, shut-off type, angle model, TENSOR ES | RRD – Chipping hammer, vibration damped |
| ETV SB – Battery nutrunner, angle model, TENSOR SB | RRF – Chipping hammer, vibration damped |
| ETV SL – Electric screwdriver, angle model, TENSOR SL | RRH – Riveting hammers, vibration damped |
| ETV ST – Electric nutrunner, shut-off type, angle model, TENSOR ST | RRN – Riveting hammer, conventional type |
| ETV STR – Electric screwdriver, angle model, TENSOR STR | RTP – Pneumatic nutrunner, pistol grip |
| ETV STB – Battery nutrunner, angle model, TENSOR STB | RUBAIR – Rubber hose |
| ETX – Fixtured electric nutrunner, shut-off type | RVM – Scaler, vibration damped |
| FIL – Air preparation unit, filter | SM – Torque arm, parallel |
| GHP – Torque arm, MicroTorque | SMC – Carbon arm |
| GTG – Turbine grinder | SML – Torque arm, linear |
| GTR – Straight turbine grinder | SPI – Spiral hose |
| GUN – Blow gun | SMS – Torque arm, linear |
| HM – Hose reel | SRTT-B – Static reaction torque transducer |
| HRIL – Hose reel | SRTT-L – Transducer for STAnalyser |
| HT – Torque testers | STB – Static Transducer Bench |
| IRTT-B – In-line rotary torque and torque/angle transducer | TLT – Trolley |
| JSB – Joint Simulator Bench | TPS – Tool Positioning System |
| LBB – Pistol grip and straight drill | TT – Torque testers |
| LBD M – Modular drill, straight model | TURBO – Rubber hose |
| LBL – Automatic drilling and tapping unit | TWIST – Pneumatic screwdriver, slip-clutch |
| LBR – Pneumatic nutrunner, stall type, ratchet wrenches | WP – Balancer |
| LBS – Micro stop drill | |
| LBV – Angle drill | |
| LBP M – Modular drills, pistol model | |
| LCS – Circular cutters | |
| LGB – Tapper | |

Industrial Tools Division Warranty

Atlas Copco Tools and Assembly Systems warrants to the customer that the products manufactured by Atlas Copco Tools and Assembly Systems and its affiliates shall be free of defects in design, material, and workmanship for the following periods of time:

- A. For portable industrial hand tools and hoists, twelve (12) months from date of shipment to customer.
- B. All 2000 Series Tools, accessories and parts, three (3) months from date of shipment of customer.

Should any failure to conform with this warranty appear prior to or after shipment of the product to customer during the specified periods under normal and proper use and provided the product has been properly stored, installed, handled and maintained by the customer, Atlas Copco Tools and Assembly Systems shall, if given prompt notice by customer, repair or replace the nonconforming product or authorize repair or replacement by the distributor. Note: This does not include standard wear items such as vanes, o-rings, etc.

Replaced products become the property of Atlas Copco Tools and Assembly Systems.

Atlas Copco Tools and Assembly Systems warrants Products or parts there of repaired or replaced pursuant to the above warranty, under normal or proper use, storage, installation and maintenance, against defects in design, workmanship and material for a period of 30 days from date of start-up of such repaired or replaced equipment or parts or the expiration of the original product warranty, whichever is longer.

Atlas Copco Tools and Assembly Systems' warranty does not extend to products not manufactured by Atlas Copco Tool and Assembly Systems or its affiliates. As to such products, customer shall be entitled to proceed only upon the terms of that particular manufacturer's warranty does not apply to defects in material provided by customer or design stipulated by customer.

Use products, products not manufactured by Atlas Copco Tools and Assembly Systems or its affiliates and products excluded from the above warranties are sold AS IS with no representation or warranty, and ALL WARRANTIES OF QUALITY, WRITTEN, ORAL OR IMPLIED, other than may be expressly agreed to by Atlas Copco Tools and Assembly Systems. In writing, INCLUDING WITHOUT LIMITATION, WARRANTIES OR MERCHANTABILITY AND FITNESS ARE HEREBY DISCLAIMED.

THE FOREGOING WARRANTIES ARE EXCLUSIVE AND IN LIEU OF ALL OTHER WARRANTIES OF QUALITY, WRITTEN, ORAL OR IMPLIED AND ALL OTHER WARRANTIES INCLUDING WITHOUT LIMITATION ANY WARRANTY OF MERCHANTABILITY OR FITNESS ARE HERBY DISCLAIMED. Correction of nonconformities as provided above shall be distributor's exclusive remedy and shall constitute fulfillment of all liabilities of Atlas Copco Tools and Assembly Systems (including any liability for direct, indirect, special incidental or consequential damages) whether in warranty, strict liability, contract, tort, negligence or otherwise with respect to the quality of or any defect in products delivered here under.

OSHA Statement

Atlas Copco Tools and Assembly Systems ("the company") represents to the original user that the products advertised herein are designed to comply with The Occupational Safety and Health Act of 1970 and as amended as of the date of manufacture. The company shall not be responsible for any failure to so comply with the Act which results from the location, operation, use or maintenance of the products or from alteration of the products by persons other than the company or from any option or accessory of the products which was available to the original user but omitted at his direction, or from design or instructions furnished by the original user.

The company's responsibility herein is limited to modification or replacement of the products so that the products conform to the regulations applicable at the time of manufacture or at the option of the company to refund to the original user the purchase price less an allowance for normal depreciation upon the return of the products to the company. By special request, a sound warranty can be offered; otherwise all standards under the Act with respect to noise are specifically excluded.

Whether in relation to the above or otherwise, the company will not indemnify the original user for any fines; penalties neither imposed nor are liable for loss due to delay or any special, indirect or consequential damages of any nature whatsoever.

